

General Instructions

These instructions provide information for installation, electrical connection, process connection and calibration of 107 Differential Pressure Switches.

NOTE: If you suspect that a product is defective, contact the factory or the SOR® Representative in your area for a return authorization number (RMA). This product should only be installed by trained and competent personnel.

Principle of Operation

Process pressure is sensed by a diaphragm and piston assembly. The piston responds to differential pressure and moves a shaft that actuates (deactuates) an electrical switching element. Low side pressure and a wetted adjustable range spring oppose high side pressure. Calibration is accomplished by adjusting the range spring with the set point adjustment screw.

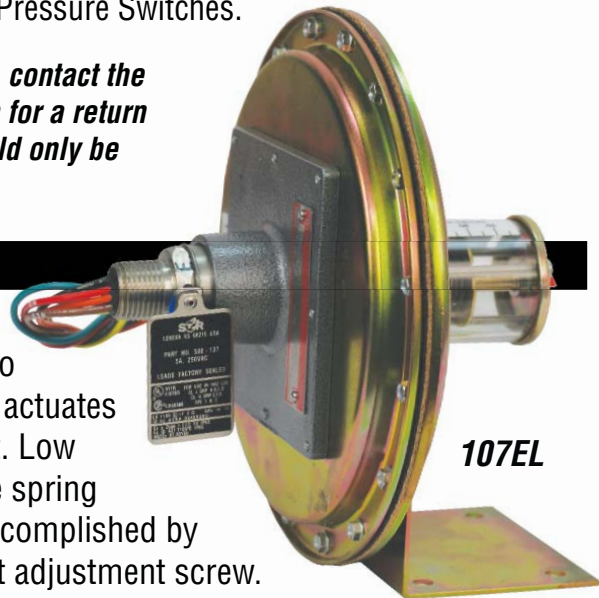

Application

The 107 Differential Pressure Switch is suited for draft range service as well as industrial air and gas services which are compatible with the wetted parts and within nameplate specifications. Contact the SOR representative in your area or the factory in Lenexa, Kansas for details.



Use care during installation not to inadvertently move the electrical switching element or its housing. Movement of either could disturb the relative positions of internal working parts and alter calibration or render the device inoperative.

Installation

The 107 is position sensitive. Mount the 107 so that the diaphragm is vertical (as shown above). Non-vertical mounting positions will cause calibration scale error.

If condensation is expected within process piping, pressure ports should be located at 6 o'clock to prevent moisture accumulation within the instrument. If condensation is not expected, the pressure ports can be positioned to any location as long as the diaphragm remains vertical.

Securely mount the base plate bracket to flat surface using suitable bolts.

*Design and specifications are subject to change without notice.
For latest revision, go to sorinc.com*

Safety Integrity Level (SIL) Installation Requirements

The SOR pressure switches have been evaluated as Type-A safety related hardware. To meet the necessary installation requirements for the SIL system, the following information must be utilized:

- Proof Test Interval shall be one year.
- Units may only be installed for use in Low Demand Mode.
- Products have a HFT (Hardware Fault Tolerance) of 0, and were evaluated in a 1oo1 (one out of one) configuration.

Form 1538 (03.12) ©2012 SOR Inc.

Process Connection

The high-pressure side (marked HIGH) and the low pressure side (marked LOW) have 1/8" NPT(F) process connections unless 1/4" NPT(F) adapters were specified.

- 1 Set point adjustment screw (not shown)
- 2 High side process connection
- 3 Low side process connection
- 4 Hermetically sealed switching element capsule
- 5 18 AWG wire leads (not shown)
- 6 1/2" NPT(M) electrical conduit connection
- 7 3/4" NPT(F) electrical conduit connection
- 8 Weatherproof switching element housing

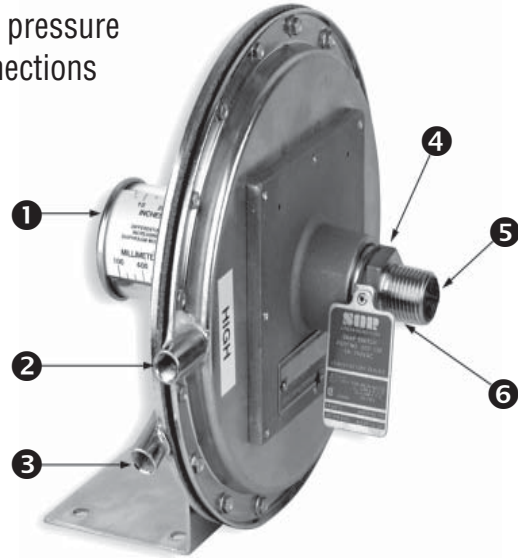

Hazardous Locations - 107EL

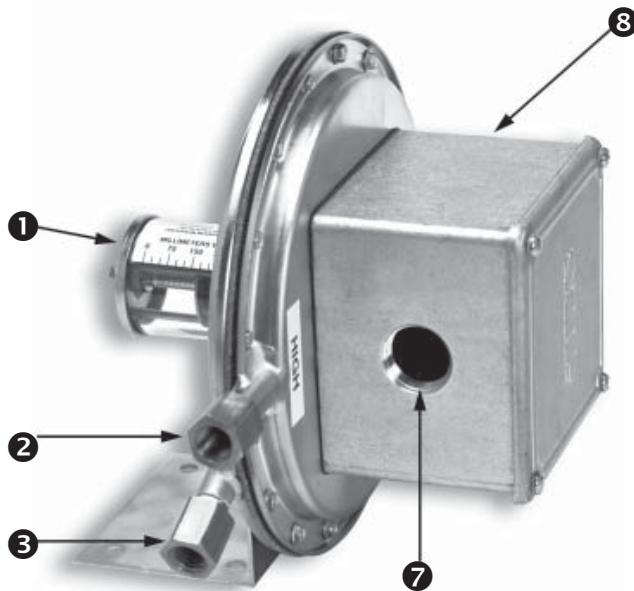

Non-Hazardous Locations - 107AL

Ensure that wiring conforms to all applicable local and national electrical codes and install unit(s) according to relevant national and local safety codes.

Electrical Connection

107AL (weatherproof):

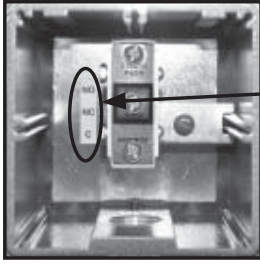

Interrupt electrical power. Remove top cover plate. Screw terminals are standard. Terminals are identified C - Common, NO - Normally Open and NC - Normally Closed. (Use terminal identification on sticker located on the floor of the housing. Do not use identification on microswitch.)

107EL (explosion proof):

Hermetically sealed switching element capsule has 18" - 18 AWG wire leads color coded and marked C - Common, NO - Normally Open, NC - Normally Closed and G - Ground (earth). (See below.)

Wire Lead Color Code



Units in hazardous locations-prior to removal from service, make sure that the work area is declassified. Failure to do so could result in severe personal injury or substantial property damage.

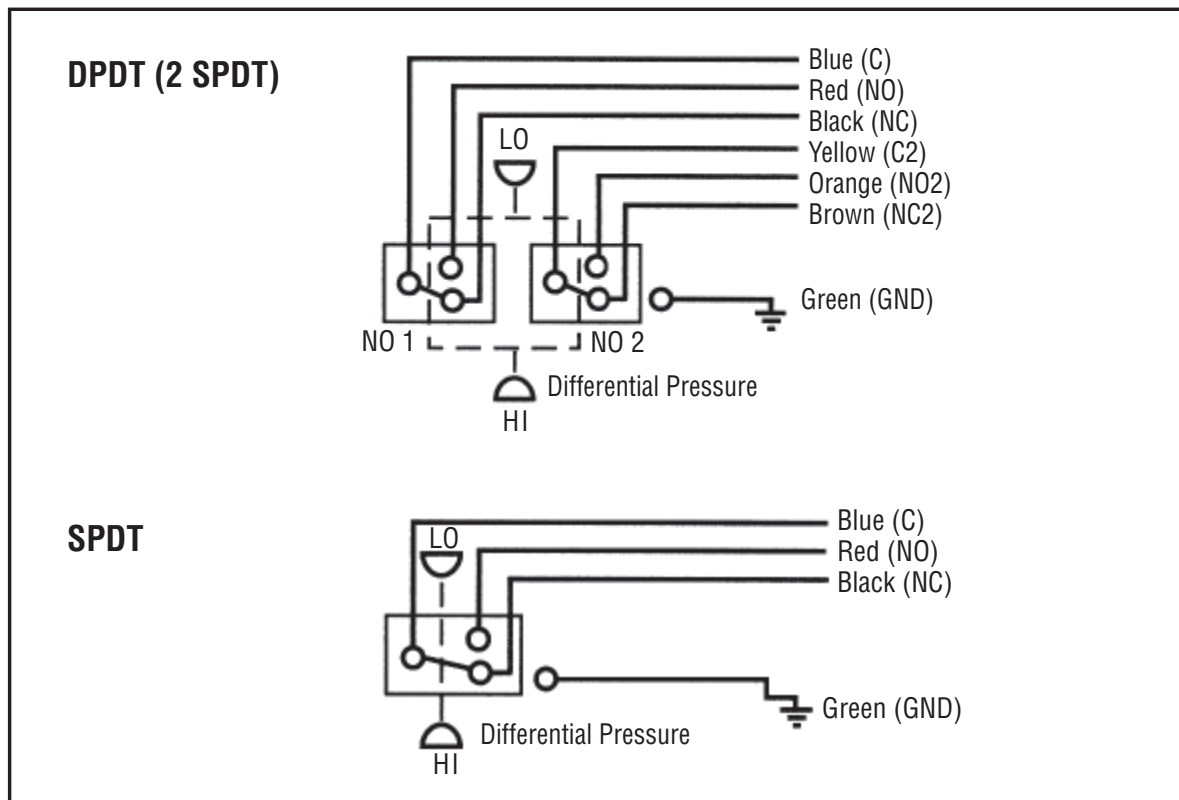

See SOR Catalog 459 for reference dimension drawings. For certified dimension drawings, contact the factory.

Calibration

Normal Calibration: Turn set point adjustment screw to move spring guide plate into alignment with desired set point on calibration scale.

Precise Calibration: Device calibrated without reference to calibration scale and low side vented.

Test apparatus: Manometer
Variable pressure source
Test light or ohmmeter

- ① Connect variable pressure source to manometer and high side pressure port.
- ② Connect test light or ohmmeter to C-Common and NO - Normally Open switching element contacts.
- ③ Raise pressure and note manometer reading when circuit closes.
- ④ Slowly drop pressure and note manometer reading when circuit opens.
- ⑤ Use a screwdriver to turn set point adjusting screw: counterclockwise to increase set point, or clockwise to decrease set point.
- ⑥ Repeat steps 3, 4 and 5 until contacts change at desired increasing or decreasing differential pressure set point.



Do not remove other covers or attempt to adjust other parts of the mechanism. All have been precisely positioned at the factory and should not be moved in the field.



Printed in USA

sorinc.com

14685 West 105th Street, Lenexa, KS 66215 ■ 913-888-2630 ■ 800-676-6794 USA ■ Fax 913-888-0767