



1230BRG Big Pressure Regulator

General Instructions



The 1230BRG Big Pressure Regulator is used with natural gas, compressed air, and other gases. Depending on the configured model, the maximum possible inlet pressure is 1500 psi (103 bar) and the temperature limits are -40°F to 180°F (-40°C to 82°C). Please refer to the 1230BRG Product Specifications section of the SOR 1200 Series Pressure Regulators Catalog (Form 1631) to determine your model's exact specifications. The application of your regulator shouldn't exceed any of the regulator's specifications.



The SOR® 1230BRG Pressure Regulator doesn't provide internal relief. A pressure relieving or pressure limiting device should be used to insure that the outlet pressure doesn't exceed the regulator's specifications while in service. Leakage, equipment damage, or personal injury can result from over-pressuring the regulator.

NOTE: If you suspect that a product is defective, contact the factory or the SOR® Representative in your area for a return material authorization number (RMA). This product should only be installed by trained and competent personnel.

Design and specifications are subject to change without notice.

For latest revision, go to sorinc.com

Table of Contents

Installation	2
Calibration	3
Maintenance	3
Replacing the Orifice	4
Replacing the Valve Disk Assembly and Casing Inlet Gasket	5
Replacing the Diaphragm	6
Parts Lists	8
Repair Kits	12
Dimensions	13
Troubleshooting	15



All SOR instructions, as well as applicable local, state, and federal codes and regulations should be adhered to when performing installation, operation, or maintenance of a regulator. Personal injury, equipment damage, or leakage can occur if the regulator is over-pressured or physically damaged. To avoid physical damage the regulator should be installed in a safe location. The regulator shouldn't be installed in systems that could exceed its specified pressure limits (given in the SOR 1200 Series Pressure Regulator Catalog). If leakage develops, then immediate service is required. Failure to remove the regulator from service immediately may create a hazardous situation.

Installation

See pages 8 for Parts List references, shown as “(25).”

NOTE: If continued operation is necessary during installation or maintenance then a three-valve bypass should be installed around the position of the regulator.

- 1 Remove all packaging plugs from the regulator body inlet and outlet connections.
- 2 Carefully inspect the regulator for damage or debris. The regulator's inlet and outlet connections should be cleaned and free of debris before installation.
- 3 Ensure that all piping that is to be connected to the regulator is clean of foreign matter as well.
- 4 Apply pipe joint material to the piping threads that will be connected to the regulator.
- 5 Shut down the process before connecting the regulator.
- 6 Connect the regulator so that the process flows in the direction of the arrow on the spring case (20).



Under certain conditions, this regulator may vent gas to the atmosphere. If operating in a hazardous process, this gas must not be allowed to accumulate and/or ignite. The user must be sure to vent the exhaust to a safe location away from any air intakes or possible ignition sources. The vent line must also be protected against clogging and condensation. Failure to safely vent hazardous gas from the regulator exhaust could result in personal injury, death, or property damage if a fire or explosion were to occur.

- 7 The regulator must be oriented such that the screen vent (25) is protected against clogging. If the regulator is being installed outside, position the vent facing downward to prohibit moisture and debris from falling directly into the vent.



Use pressure gauges to monitor the outlet pressure of the regulator during startup and vent the downstream pressure if necessary. The presence of downstream pressure during the startup of the regulator may cause the diaphragm of the regulator to be overpressured. This condition could cause personal injury or property damage if the regulator is overpressured to the point of explosion.

- 8 Slowly begin flowing gas through the regulator.
- 9 Verify that the regulator isn't leaking from any connection points.
- 10 Proceed to the Calibration section.

Calibration



While calibrating the unit always use a pressure gauge to monitor the pressure.



Under normal circumstances, the outlet pressure should not exceed the output range of the spring.

- 1 Loosen the jam nut (1).
- 2 To increase the set point, rotate the adjusting screw (8) clockwise.
- 3 To decrease the set point, rotate the adjusting screw (8) counter-clockwise.
- 4 Once desired set point has been achieved, re-tighten the jam nut (1) while keeping the adjusting screw's (8) position fixed.

Maintenance

Regulators accumulate general wear over time and must be inspected/evaluated for the possible need to repair or replace the instrument in accordance with local, state, and federal rules and regulations. SOR offers spare parts and repair kits for customers to order and keep on hand for routine maintenance.



To avoid personal injury or equipment damage resulting from sudden release of pressure or ignition of accumulated gas, isolate the regulator from the system and bleed all of its internal pressure before attempting maintenance procedures.

ROTATING THE RANGE SPRING



Before proceeding, loosen the jam nut (1) and release all spring tension by rotating the adjusting screw (8) counter-clockwise until the range spring (21) is completely relaxed.

- 1 Remove the two blind casing screws (4) and four casing screws (5) with hex nuts (3) that hold the spring case (20) and diaphragm casing (13) together.
- 2 Remove the original spring and install the replacement range spring (21) on top of the lower spring seat (11). Then place the upper spring seat (22) atop the range spring (21).
- 3 Re-install the spring case (20) back onto the diaphragm casing (13).



When re-assembling the spring case (20) and diaphragm casing (13), the orientation must be as shown in the following diagrams, with the nameplate opposite the diaphragm casing (13) and inlet adapter (16) – if the mounting holes are not in the proper alignment the regulator will not operate as intended.

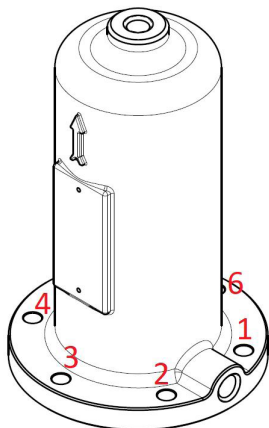
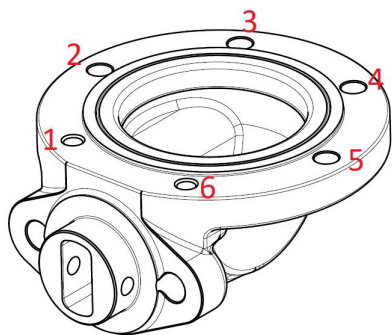

- ④ Reinstall and hand-tighten the blind casing screws (4), casing screws (5) and casing hex nuts (3) back through the spring case (20) and diaphragm casing (13).



The blind casing screws (4) must be used with casing hole numbers 1 and 6.

- ⑤ Rotate the adjusting screw (8) clockwise until the range spring (21) is compressed slightly adding slack to the diaphragm (12).
- ⑥ Complete tightening the blind casing screws (4), casing screws (5), and casing hex nuts (3) until securely fastened.
- ⑦ Re-calibrate the regulator to the desired set point per Calibration procedure.

REPLACING THE ORIFICE

NOTE: Some piping arrangements may allow maintenance of the orifice (18) and valve disk assembly (24) without requiring the inlet adapter (16) to be disconnected from the piping. If the inlet adapter (16) and body (9) can be separated enough to allow access to the orifice (18) and valve disk assembly (24), step 1 in the below procedure can be skipped.



Before proceeding, loosen the jam nut (1) and release all spring tension by rotating the adjusting screw (8) counter-clockwise until the range spring (21) is completely relaxed.

- ① Disconnect the process piping and the inlet adapter (16).
- ② Remove the four inlet adapter screws (7) that hold the body (9) and inlet adapter (16) together.
- ③ The orifice (18) is seated in recess of the inlet adapter (16) and has a body inlet gasket (15) on top and below it.

- 4 Remove the worn orifice (18) and body inlet gaskets (15) and install the replacement body inlet gaskets (15) and orifice (18) in the recess of the inlet adapter (16).
- 5 Re-connect the body (9) and inlet adapter (16), insert the four inlet adapter screws (7) through the inlet adapter (16) and tighten.
- 6 Re-calibrate the regulator to the desired set point per Calibration procedure.

REPLACING THE VALVE DISK ASSEMBLY AND CASING INLET GASKET (included in SOR Disk & Diaphragm Repair Kit)

NOTE: Some piping arrangements may allow maintenance of the orifice (18) and valve disk assembly (24) without requiring the inlet adapter (16) to be disconnected from the piping. If the inlet adapter (16) and body (9) can be separated enough to allow access to the orifice (18) and valve disk assembly (24), step 1 in the below procedure can be skipped.



Before proceeding, loosen the jam nut (1) and add spring tension by rotating the adjusting screw (8) clockwise for 2 complete turns past the point it first contacts the upper spring seat (22). This separates the valve disk face (24) from the orifice (18) so neither becomes damaged during maintenance.

- 1 Disconnect the process piping and the inlet adapter (16)
- 2 Remove the four inlet adapter screws (7) that hold the body (9) and inlet adapter (16) together and separate.
- 3 Remove the two body screws (2) that hold the diaphragm casing (13) and body (9) together and separate.
- 4 Remove the worn casing inlet gasket (14) from the diaphragm casing (13) and install the replacement casing inlet gasket (14).
- 5 The valve disk assembly (24) is connected to the valve disk carrier (23) which is located inside the body (9). Slide the valve disk carrier assembly (23 + 24) out from the body (9).
- 6 Unscrew the valve disk assembly (24) from the valve disk carrier (23) using a 3/4" / 19.1 mm socket wrench. Install the replacement valve disk assembly (24) into the valve disk carrier (23).
- 7 Insert the valve disk carrier assembly (23 + 24) back into the body (9) with the valve disk assembly (24) facing towards the regulator inlet connection.

NOTE: Ensure the valve disk carrier (23) notch is centered within the body (9) and facing outwards allowing the pinned-end lever (17) to seat itself into the notch when the body (9) and diaphragm casing (13) are re-assembled.

- 8 Insert the pinned-end of the lever (17) through the body (9) opening and seat it in the valve disk carrier (23) notch.
- 9 With the lever (17) and valve disk carrier (23) notched together, slide the body (9) and diaphragm casing (13) back together. Reinstall the two body screws (2) and tighten.



Before proceeding ensure the lever (17) is properly connected with the valve disk carrier (23) and will engage the valve disk carrier (23) during operation.

- ⑩ Check and ensure the body inlet gaskets (15) and orifice (18) are still nested in the recess of the inlet adapter (16).
- ⑪ Re-connect the body (9) and inlet adapter (16), insert the four inlet adapter screws (7) through the inlet adapter (16) and tighten.
- ⑫ Re-calibrate the regulator to the desired set point per Calibration procedure.

REPLACING THE DIAPHRAGM

(included in SOR Disk & Diaphragm Repair Kit)



Before proceeding, loosen the jam nut (1) and release all spring tension by rotating the adjusting screw (8) counter-clockwise until the range spring (21) is completely relaxed.

- ① Remove the two blind casing screws (4) and four casing screws (5) with hex nuts (3) that hold the spring case (20) and diaphragm casing (13) together.
- ② To access the diaphragm assembly, remove the spring case (20), range spring (21), and upper spring seat (22) and set aside for reassembly.

NOTE: The diaphragm assembly consists of the connector head (10), diaphragm (12), and lower spring seat (11), and is held together by the connector head screw (6).

- ③ Remove the diaphragm assembly from the diaphragm casing (13) by unhooking the bottom of the connector head (10) from the lever (17).

NOTE: If the diaphragm assembly is having difficulties being unhooked from the lever (17), start by sliding the diaphragm assembly away from the inlet adapter (16) and body (9) and then pull the diaphragm assembly straight up and out from the diaphragm casing (13).

- ④ Unscrew the connector head screw (6) from the connector head (10) and remove the lower spring seat (11) followed by the worn diaphragm (12).
- ⑤ Place the lower spring seat (11) back on the connector head screw (6) in the same orientation it was removed. Install the replacement diaphragm (12) onto the connector head screw (6) and thread the connector head screw (6) back into the connector head (10).



After rebuilding the diaphragm assembly, make sure the diaphragm (10) is centered on the connector head (10). If it is not centered the regulator may potentially leak during operation.

- ⑥ Insert the diaphragm assembly back into the diaphragm casing (13) making certain the bottom of the connector head (10) is securely hooked onto the lever (17).

NOTE: If the diaphragm assembly is having difficulties hooking back onto the lever (17), start by inserting the diaphragm assembly into the diaphragm casing (13) on the side opposite the inlet adapter (16) and body (9). With the diaphragm assembly inserted fully, slide it towards the inlet adapter (16) and body (9) until it hooks into the lever (17).



When reconnecting the diaphragm assembly and lever (17) do not twist the diaphragm assembly to seat it into place. Doing so may hinder the regulator from operating properly.

- 7 Place the range spring (21) on top of the lower spring seat (11) and on top of the range spring (21), place the upper spring seat (22).
- 8 Re-install the spring case (20) back onto the diaphragm casing (13).



When re-assembling the spring case (20) and diaphragm casing (13), the orientation must be as shown in the following diagrams, with the nameplate opposite the diaphragm casing (13) and inlet adapter (16) – if the mounting holes are not in the proper alignment the regulator will not operate as intended.

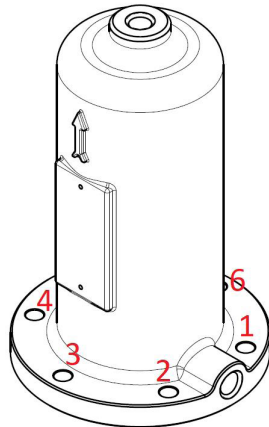
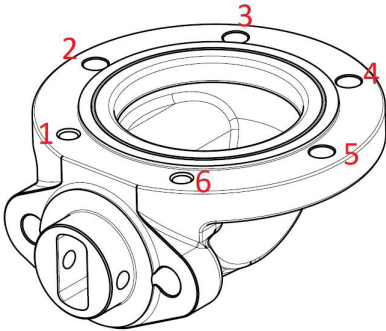

- 9 Reinstall and hand-tighten the blind casing screws (4), casing screws (5) and casing hex nuts (3) back through the spring case (20) and diaphragm casing (13).



The blind casing screws (4) must be used with casing hole numbers 1 and 6.

- 10 Rotate the adjusting screw (8) clockwise until the range spring (21) is compressed slightly adding slack to the diaphragm (12).
- 11 Complete tightening the blind casing screws (4), casing screws (5), and casing hex nuts (3) until securely fastened.
- 12 Re-calibrate the regulator to the desired set point per Calibration procedure.

1230BRG - 1" Body Size

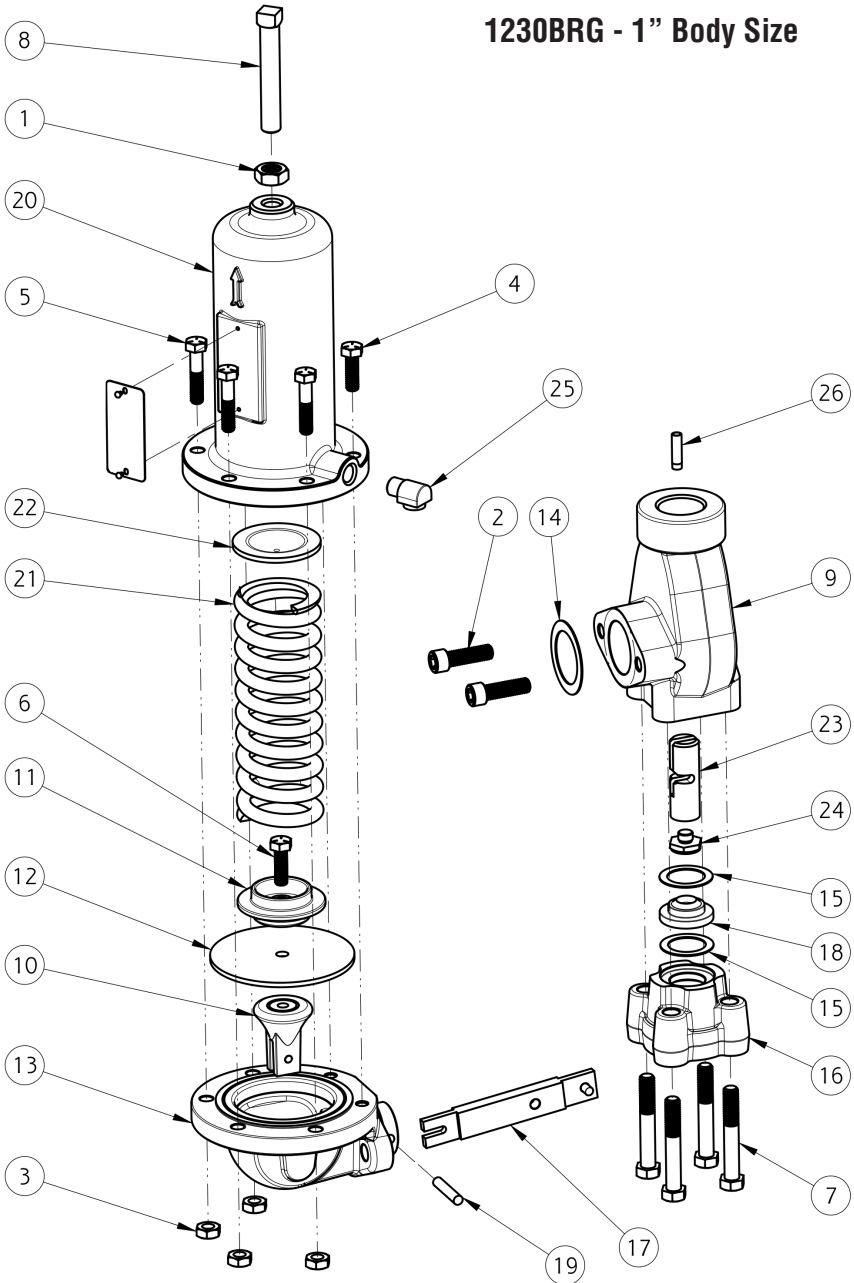

1230BRG - 1" Body Size

Item	Description	Qty.
1	Jam Nut	1
2	Body Screw	2
3	Casing Hex Nut	4
4	Blind Casing Screw	2
5	Casing Screw	4
6	Connector Head Screw	1
7	Inlet Adapter Screw	4
8	Adjusting Screw	1
9	1" Body	1
10	Connector Head	1
11	Lower Spring Seat	1
12*	Diaphragm	1
13	Diaphragm Casing	1
14*	Casing Inlet Gasket	1
15*	Body Inlet Gasket	2
16	1" Inlet Adapter	1
17	Lever	1
18	Orifice	1
19	Lever Pin	1
20	Spring Case	1
21	Range Spring	1
22	Upper Spring Seat	1
23	Valve Disk Carrier	1
24*	Valve Disk Assembly	1
25	Screen Vent Assembly	1
26	Pitot Tube	1

* Included with SOR Disk & Diaphragm Repair Kit

1230BRG - 2" Body Size

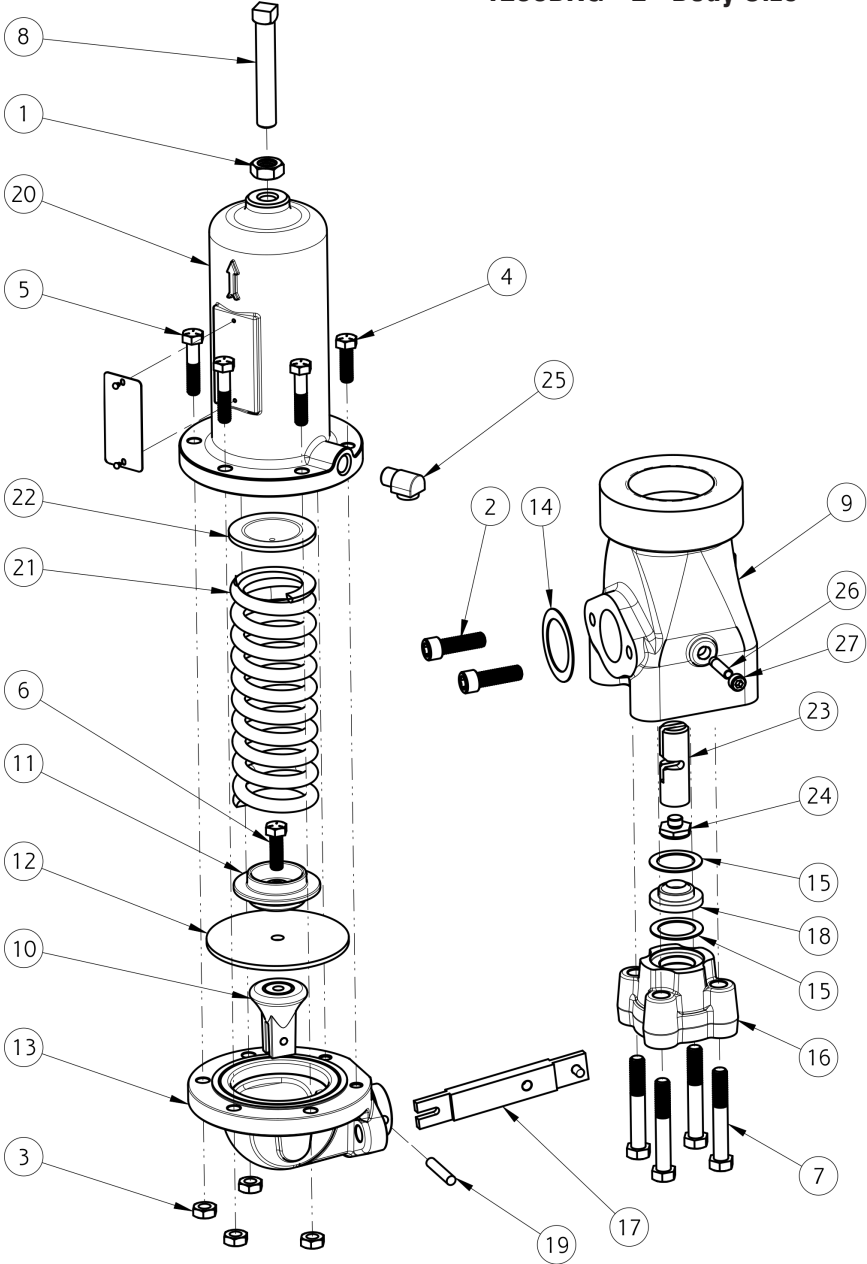

1230BRG - 2" Body Size

Item	Description	Qty.
1	Jam Nut	1
2	Body Screw	2
3	Casing Hex Nut	4
4	Blind Casing Screw	2
5	Casing Screw	4
6	Connector Head Screw	1
7	Inlet Adapter Screw	4
8	Adjusting Screw	1
9	2" Body	1
10	Connector Head	1
11	Lower Spring Seat	1
12*	Diaphragm	1
13	Diaphragm Casing	1
14*	Casing Inlet Gasket	1
15*	Body Inlet Gasket	2
16	2" Inlet Adapter	1
17	Lever	1
18	Orifice	1
19	Lever Pin	1
20	Spring Case	1
21	Range Spring	1
22	Upper Spring Seat	1
23	Valve Disk Carrier	1
24*	Valve Disk Assembly	1
25	Screen Vent Assembly	1
26	Pitot Tube	1
27	Plug	1

* Included with SOR-Disk & Diaphragm Repair Kit

Repair Kits

Orifice Replacement Kits

Material	Size		Part No.
Brass	1/8"	3.2 mm	6231110
	3/16"	4.8 mm	6231111
	1/4"	6.4 mm	6231112
	3/8"	9.5 mm	6231113
	1/2"	13 mm	6231114
Stainless Steel	1/8"	3.2 mm	6231115
	3/16"	4.8 mm	6231116
	1/4"	6.4 mm	6231117
	3/8"	9.5 mm	6231118
	1/2"	13 mm	6231119

Replacement Springs

Color (Range)	Part No.
Red Striped Spring (27-50 psi)	6231174
Olive Striped Spring (46-95 psi)	6231175
Silver Spring (90-150 psi)	6231176
Green Striped Spring (150-200 psi)	6231177
Blue Striped Spring (200-275 psi)	6231178
Yellow Striped Spring (275-500 psi)	6231179

Disk & Diaphragm Repair Kits

Materials of Construction	Part No.
Neoprene Diaphragm & Brass / NBR Valve Disk Assembly	6231193P
Neoprene Diaphragm & Brass / PTFE Valve Disk Assembly	6231194P
Neoprene Diaphragm & Stainless Steel / NBR Valve Disk Assembly	6231195P
Fluorocarbon Diaphragm & Stainless Steel / PTFE Valve Disk Assembly	6231196P

Disk & Diaphragm Repair Kits include: Diaphragm, Casing Inlet Gasket, Body Inlet Gaskets, and Valve Disk Assembly.

NOTE: Repair Kits with alternative Valve Disk/Trim/Diaphragm material combinations can be provided upon request. Consult factory for details.

1" NPT / DN 25 Body

Linear = mm/inches

Drawing 6231197

*Dimensions are for reference only.
Contact the factory for certified drawings
for a particular model number.*

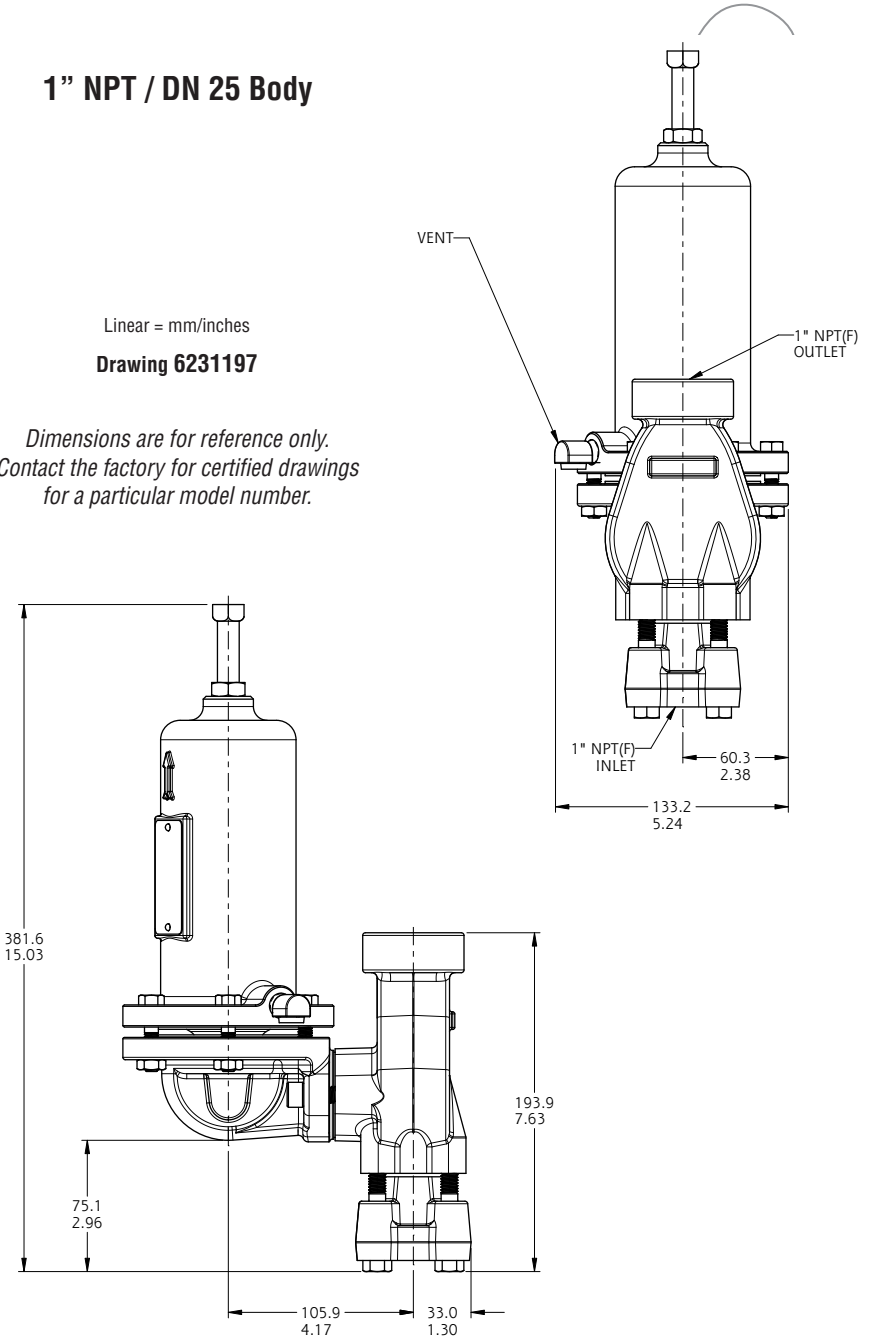

2" NPT / DN 50 Body

Linear = mm/inches

Drawing 6231198

*Dimensions are for reference only.
Contact the factory for certified drawings
for a particular model number.*

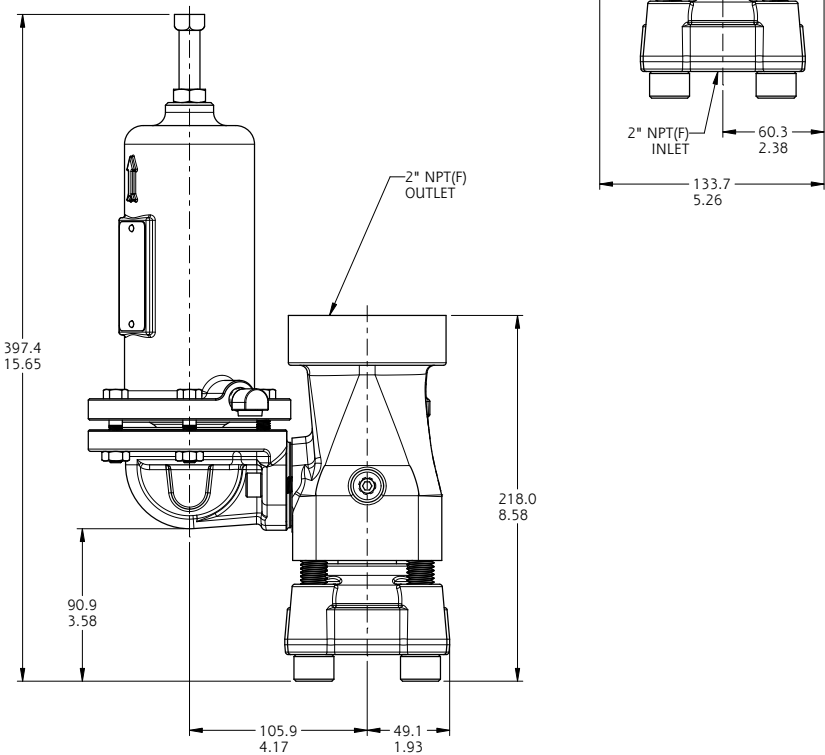

Troubleshooting



To avoid personal injury or equipment damage resulting from sudden release of pressure, or ignition of accumulated gas, isolate the regulator from the system and bleed all of its internal pressure before attempting troubleshooting procedures.

Symptom	Probable Cause(s)	Corrective Action(s)
Leak occurring at body, detected through performance and/or the sound of gas leaking	Unit is improperly installed	Refer to Installation procedure on page 2
Unit does not hold pressure	Set point is not adjusted properly and is set too low	Refer to Calibration procedure on page 3
No outlet pressure from unit	Set point is not adjusted properly and is set too high	Refer to Calibration procedure on page 3
	Inlet and outlet connections installed with opposite orientation relative to pipeline flow	Refer to Installation procedure on page 2. Additionally, there is an arrow marked on the 1230BRG spring case indicating the direction of gas flow through the regulator inlet and outlet connections.

DISCONTINUED

Printed in USA



sorinc.com

14685 West 105th Street, Lenexa, KS 66215 ■ 913-888-2630 ■ 800-676-6794 USA ■ Fax 913-888-0767

16/16 Registered Quality System to ISO 9001

Form 1794 (07.19) ©SOR Inc.