



MEASUREMENT AND CONTROL

1600 Series Liquid Level Controllers

1600 series liquid level controllers are manufactured to be ideal for oilfield scrubber and separator applications. Their rugged and versatile design makes them the preferred choice of production operators for reliable service in a wide variety of applications. 1600 series controllers are available with pneumatic snap or throttling pilot; direct or reverse action; with a variety of displacer sizes, materials and vessel connections.

Features

- Weather proof case utilizes a gasket between its cover and case to seal out the effects of outside weathering
- Well suited for liquid-liquid interface detection
- Controller case is easily field reversible
- Standard displacer materials are PVC and 316 stainless steel
- Available with wetted materials that meet NACE MR0175 specifications for sour service
- CRN certification available
- LeakTite™ no bleed pilot for limiting fugitive emissions to meet EPA regulations
- Electric Pilot option available to eliminate the need for pneumatic gas supply



Product Specifications

Materials of Construction

Body	Carbon Steel
Case & Cover	Die Cast Aluminum
Pilots	Aluminum w/SS Internals
Pilot Gaskets/Diaphragm	Neoprene
Gauges	Brass or Vibration Resistant Brass 316SS or Vibration Resistant 316SS (optional)
Shaft	316SS
Bearing Blocks	316SS
Bearings	Stainless Steel
Seals	Buna-N Viton® (optional)
Displacer	PVC 316SS (optional)
Displacer Arm	316 Stainless Steel
Vertical Hanger (Swivel)	316 Stainless Steel

Weight

Threaded	≈ 20 lbs.
Flanged	Consult Factory

Available End Connection Sizes

Threaded & Butt Weld	2"
Flanged	2", 3", 4", 6"

Pneumatic Pilots

Snap (on/off)	0-20/0-30 psi output
Throttle (modulating)	3-15/6-30 psi output

Electronic Pilot

SPDT	15A@125, 250 and 480 VAC
Approvals	Div 1&2, Class I, Groups B, C, & D Div 1&2, Class II, Groups E, F, & G II 2 G Ex d IIB + H2 T6 Gb

Agency Approvals	UL, CSA, ATEX, IECEX, InMETRO
------------------	----------------------------------

Electrical Connection	1/2" NPT (M)
-----------------------	--------------

Supply Pressure Requirement

3-15 or 0-20 psi output	20-30 psi min.
6-30 or 0-30 psi output	35-40 psi min.

Supply & Output Connections

Pneumatic Pilots: 1/4" NPTF

Pressure Ratings	2" Threaded: 6000 psi Flanged: 2220 psi (900#)
------------------	---

Specific Gravity (minimum allowable fluid)

Snap and No Bleed Pilot	0.35
Throttling Pilot	0.60
Interface Minimum Differential	0.04

1600 Series Liquid Level Controllers

Principles of Operation

The 1600 series liquid level controllers are designed to sense a liquid level and supply a pneumatic signal to a control valve to control the level of the process liquid. The 1600 series liquid level controllers sense the liquid level using a displacer and then is configured to operate a pneumatic pilot at field selectable set points.

The 1600 series uses a displacer to sense the liquid level in process vessels. As the process liquid rises the displacer's effective weight is reduced. Depending on the set points that the level controller has been configured to operate at, the pilot will supply a pneumatic signal to a control valve to control the level of the process fluid.

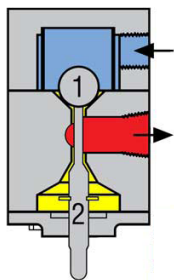
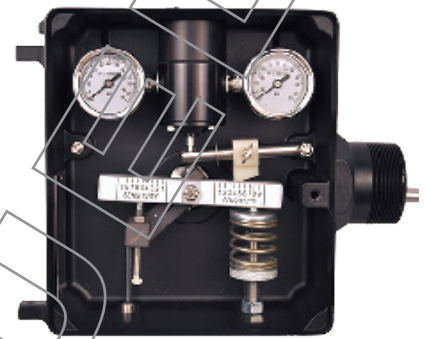

Snap Pilot



The pilot in the 1600 series controls when the inserted pneumatic gas is sent through the outlet port to control pneumatic equipment such as a control valve. The pilot is made up of two valves. The first valve is used to allow pressure through the outlet port and the second is used to exhaust pressure.

First the pneumatic air enters the inlet port with a specific pressure. This pressure pushes down on valve "1" creating a downward force holding the valve closed.

Once the level interfaces reaches the desired set point, the displacer arm will rotate the torque bar arm, thrusting the pin upwards to open valve "1" and allow the pneumatic air to flow through the outlet port. This in turn, closes the exhaust valve "2".

When the level has dropped enough for the displacer arm to be lowered, the pin will lower, closing valve "1". Once valve "1" is closed, valve "2" will open to exhaust any pressure left in the housing.

The throttling pilot works similarly to the snap pilot. The difference being a diaphragm "3" and spring "4" are used in conjunction with valves "1" and "2" to create a force balanced throttling pilot.

When the level has been raised enough, the force from the rising displacer will force the pin upwards opening valve "1" allowing the inlet pressure to flow through the outlet port. This outlet pressure also pushes on the diaphragm "3" to create a force balance.

If the force acting on the pin changes, the valve "1" will either open or close to allow the forces to become balanced once again. If valve "1" closes, the pressure will be exhausted through valve 2.

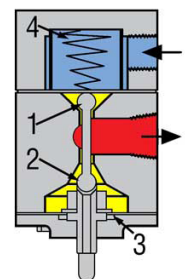

Throttle Pilot



LeakTite No Bleed Snap Pilot

The SOR LeakTite no bleed snap pilot also operates like the snap pilot, with the only difference being an elastomer sealing gasket to ensure proper sealing on valve "1" and "2". This added layer of sealing protection prevents the chance of hydrocarbon gasses leaking and meets the strict requirements of the EPA.

SPDT Electric Pilot

The SPDT Electric Pilot uses an explosion proof electric switch to eliminate the need for a pneumatic gas supply. The electric pilot will send an electric signal on high or low level to an electric actuator on a valve or to a pump for pump control. Consult factory for ordering instructions.

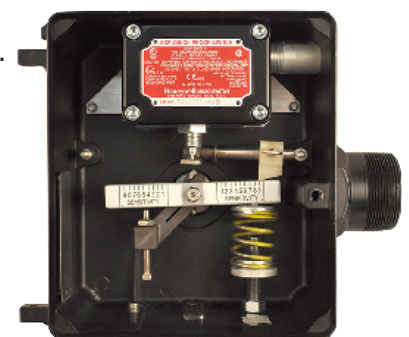

1600 Series Liquid Level Controllers

How to Order

Below is the SOR quick select model number tree that provides you with all the options to configure and order a product for your application.

- You must select a designator for each component
- Reference tables, charts and additional information are provided throughout the catalog to help you make your selections, see pages noted in the tree.

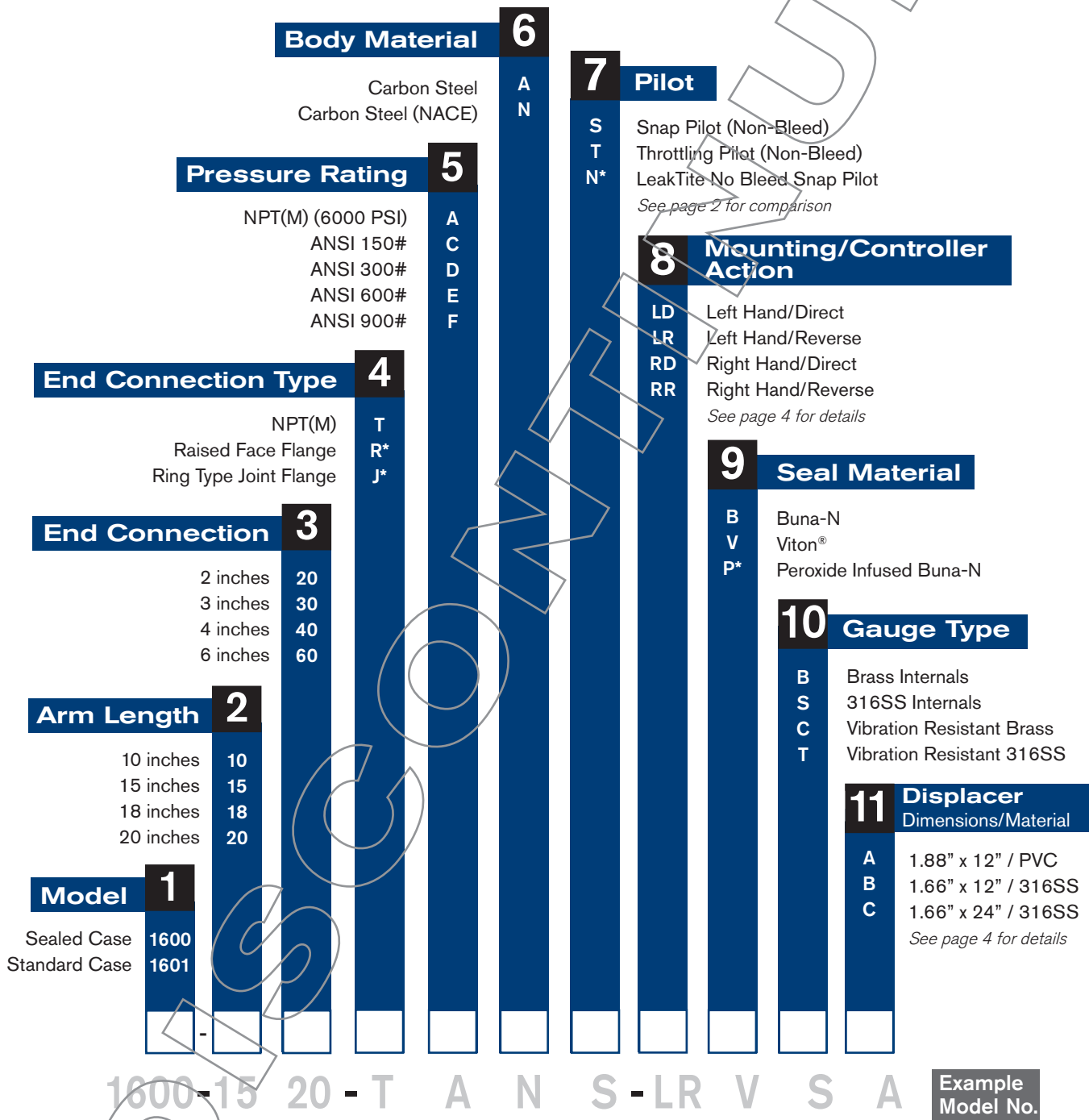

* Options may change specifications and dimensions, contact Customer Service for more information.

1600 Series Liquid Level Controllers

Specification Guidelines

Operating Temperature Limits

Body Material	Seals	Displacer Material	Temperature Limits	
			°F	°C
Carbon Steel	Buna	PVC	-40 to 140	-40 to 60
		316SS	-40 to 180	-40 to 82
	Viton®	PVC	-20 to 140	-29 to 60
		316SS	-20 to 400	-29 to 204

Displacer Pressure Ratings

Displacer Material	Maximum Pressure (psig)
PVC	6000
316 Stainless Steel	2000 at 100°F (38°C)

Right or Left Mount

The 1600 Series can be configured as a right-hand mount or left-hand mount. The orientation of the displacer to the controller (while facing the front side of the controller) designates the mounting style. The mounting can be adjusted in the field.

LEFT HAND MOUNT

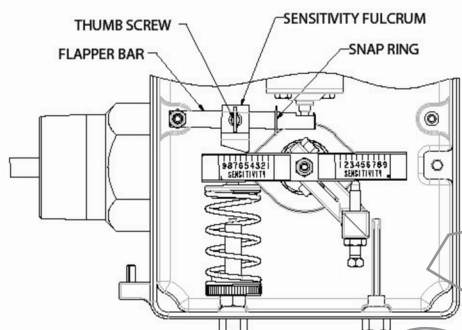

DIRECT ACTING

Rising Level INCREASES Pilot Output

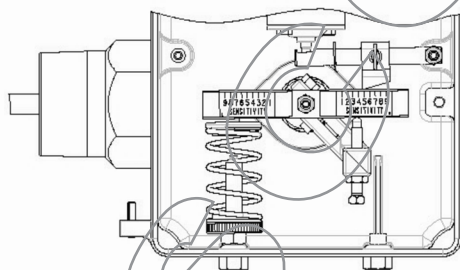

REVERSE ACTING

Rising Level DECREASES Pilot Output

RIGHT HAND MOUNT

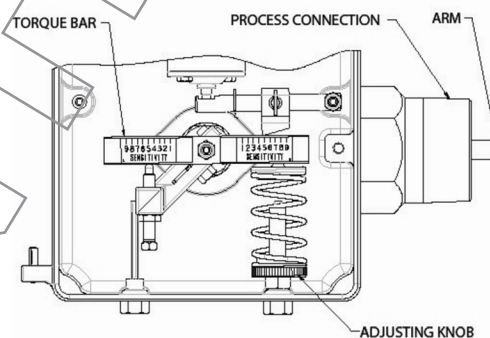

DIRECT ACTING

Rising Level INCREASES Pilot Output

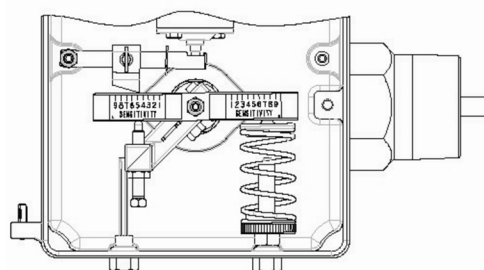

REVERSE ACTING

Rising Level DECREASES Pilot Output

Controller action is "Direct Acting" when the output signal increases as the liquid level rises on the displacer. In "Reverse Acting," the output signal decreases as the liquid level increases on the displacer.

1600 Series Liquid Level Controllers

Proportional Band

The Proportional Band is referred to as the percentage of the displacer that is used to actuate the level controller. For example, if 9 inches of change in level will actuate the level controller and a 12" long displacer is used, then the level controller will have a 75% proportional band. To adjust the proportional band, slide the fulcrum on the flapper bar along the sensitivity scale. To decrease the proportional band, increase the sensitivity. To increase the proportional band, decrease the sensitivity.

Controller Action

The Controller Action is determined by the orientation of the flapper bar as shown on page "4". When the flapper bar pivot point is on the same side as the spring, the controller action is "Direct Acting". When the flapper bar pivot point is on the opposite side as the spring, it is a "Reverse Acting" controller. The controller action is either direct acting or reverse acting. A "Direct Acting" controller will increase the output signal as the liquid rises. For a "Reverse Acting" controller, the output signal will decrease as the pressure rises.

Mounting

The mounting of the 1600 series liquid level controller is determined by the orientation of the body and displacer arm. While facing the front of the controller case, the side that body and displacer arm are oriented determines the mounting style. If the displacer is on the right side of the controller case while facing the front of the controller, then it is considered "right-hand". If the displacer is on the left side of the controller case while facing the front of the controller, then it is considered "left-hand". The mounting configuration can be easily changed out in the field.

Repair Kits

Sealed Door Assembly	5678484P	Pilot Replacement Kits	Throttling	Quick Opening	
Standard Door Assembly	5678483P		Sealed (1600)		
Displacer Assembly Kits			With Plugs	5678390P	5678292P
Displacer Kit 12" 316SST	5678481P		Non-Sealed (1601)		
Displacer Kit 12" PVC	5678480P		Brass	5678388P	5678393P
Displacer Kit 24" 316SST	5678482P		Vibration Resistant Brass	5678386P	5678395P
Pilot Repair Kits			316SS	5678389P	5678394P
Quick Opening	5678476P		Vibration Resistant 316SS	5678387P	5678396P
Throttling	5678477P		Without Plugs	5678392P	5678123P
Swivel Assembly Kit	5678485P				
Process Seal Repair Kit BUNA-N	5678478P				
Process Seal Repair Kit VITON	5678479P				

1600 Series Liquid Level Controllers

Dimensions

Dimensions in this catalog are for reference only. They may be changed without notice. Contact the factory for certified drawings for a particular model number. Dimensions are expressed as millimeters over inches (Linear = mm/in.)

1600 Sealed Case Level Controller

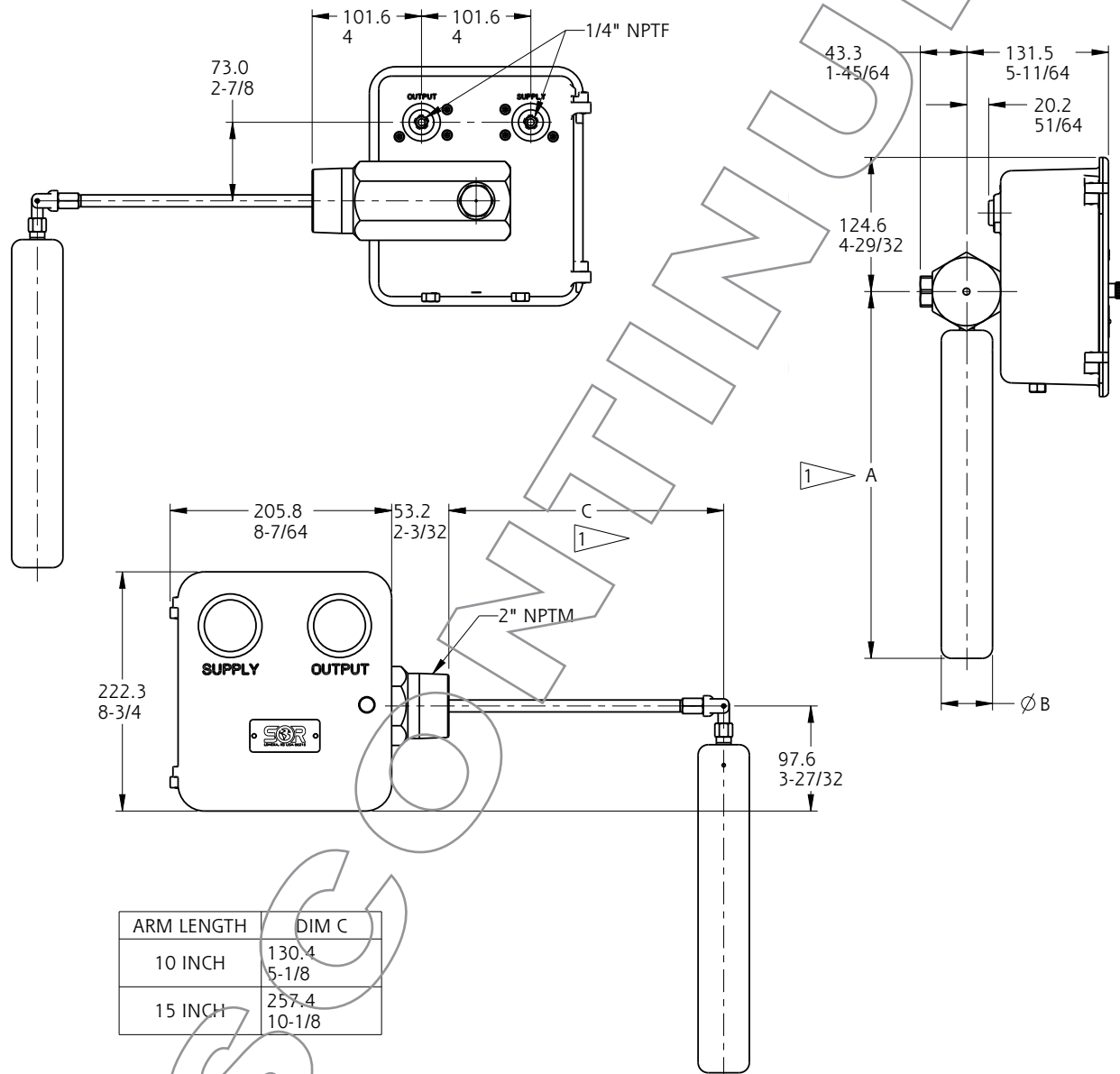

ARM LENGTH	DIM C
10 INCH	130.4 5-1/8
15 INCH	257.4 10-1/8

DISPLACER	DIM A	DIM B
1.88 X 12 PVC	340.8 13-27/64	47.6 1-7/8
1.66 X 12 316SST	340.8 13-27/64	42.2 1-21/32
1.66 X 24 316SST	645.6 25-27/64	42.2 1-21/32

NOTES:
1. DIMENSION APPROXIMATE AND BASED ON A FIVE THREAD ENGAGEMENT.

Drawing 5678451

1600 Series Liquid Level Controllers

Dimensions

Dimensions in this catalog are for reference only. They may be changed without notice. Contact the factory for certified drawings for a particular model number. Dimensions are expressed as millimeters over inches (Linear = mm/in.)

1600 Sealed Case Flanged Level Controller

ARM LENGTH	DIM E
15 INCH	407.8 16-1/16
18 INCH	484 19-1/16
20 INCH	534.8 21-1/16

DISPLACER	DIM C	DIM D
1.88 X 12 PVC	340.8 13-27/64	47.6 1-7/8
1.66 X 12 316SST	340.8 13-27/64	42.2 1-21/32
1.66 X 24 316SST	645.6 25-27/64	42.2 1-21/32

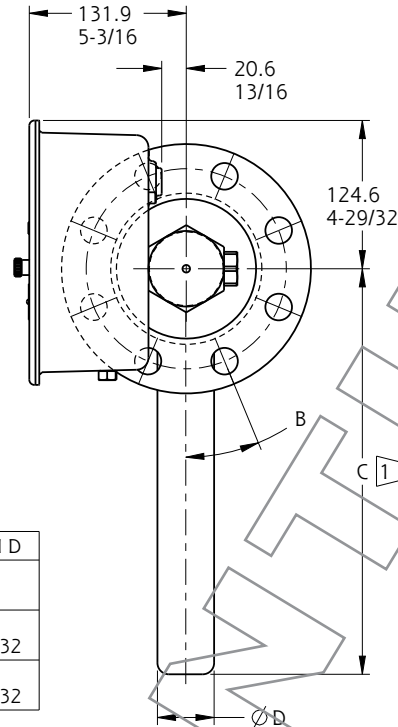

FLANGE	DIM A	DIM B
2" 150# RF	165.1 6-1/2	45°
2" 300# RF	173 6-13/16	22.5°
2" 600# RF	182.6 7-3/16	22.5°
2" 900# RTJ	204.7 8-1/16	22.5°
2" 1500# RTJ	204.7 8-1/16	22.5°
3" 150# RF	166.6 6-9/16	45°
3" 300# RF	171.5 6-3/4	22.5°
3" 600# RF	181.1 7-1/8	22.5°
3" 900# RTJ	246.1 9-11/16	22.5°
3" 1500# RTJ	261.9 10-5/16	22.5°
4" 150# RF	166.6 6-9/16	22.5°
4" 300# RF	174.8 6-7/8	22.5°
4" 600# RF	190.5 7-1/2	22.5°
4" 900# RTJ	258.8 10-3/16	22.5°
4" 1500# RTJ	271.5 10-11/16	22.5°
6" 150# RF	222.3 8-3/4	22.5°
6" 300# RF	233.4 9-3/16	15°
6" 600# RF	257.3 10-1/8	15°
6" 900# RTJ	270 10-5/8	15°
6" 1500# RTJ	303.3 11-15/16	15°

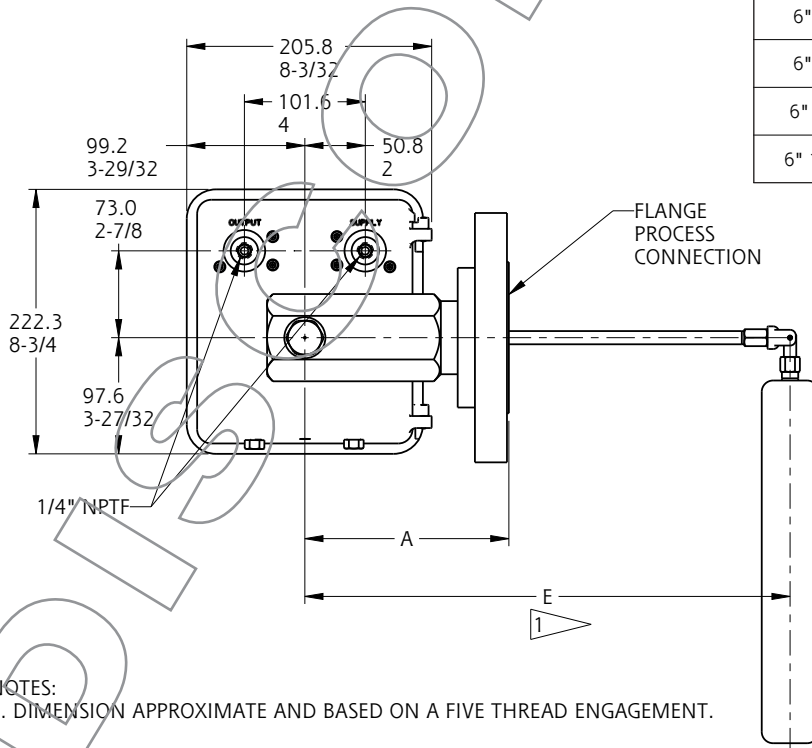

Drawing 5678447

NOTES:
1. DIMENSION APPROXIMATE AND BASED ON A FIVE THREAD ENGAGEMENT.

1600 Series Liquid Level Controllers

Dimensions

Dimensions in this catalog are for reference only. They may be changed without notice. Contact the factory for certified drawings for a particular model number. Dimensions are expressed as millimeters over inches (Linear = mm/in.)

1601 Standard Case Level Controller

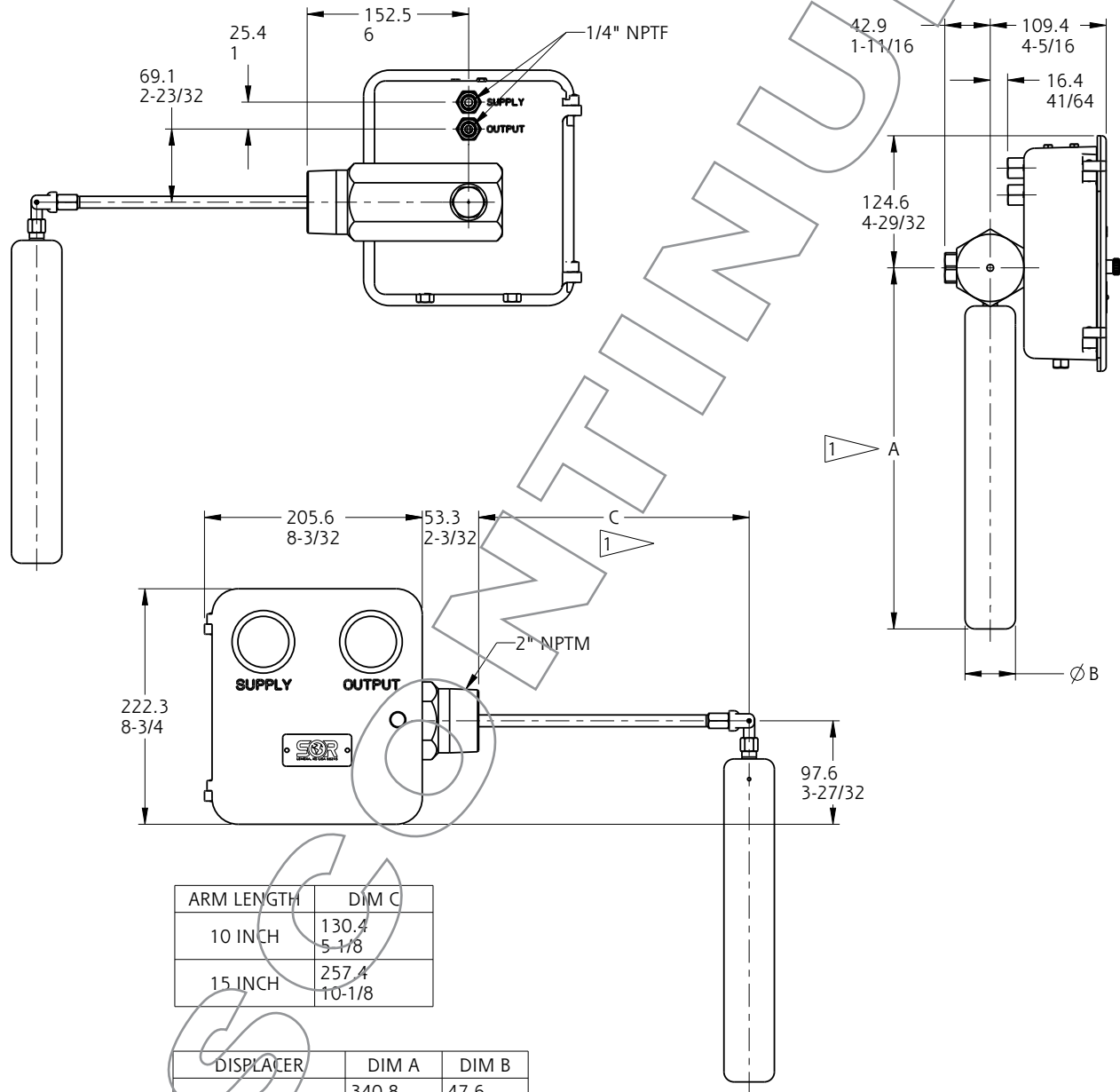

ARM LENGTH	DIM C
10 INCH	130.4 5-1/8
15 INCH	257.4 10-1/8

DISPLACER	DIM A	DIM B
1.88 X 12 PVC	340.8 13-27/64	47.6 1-7/8
1.66 X 12 316SST	340.8 13-27/64	42.2 1-21/32
1.66 X 24 316SST	645.6 25-27/64	42.2 1-21/32

NOTES:
1. DIMENSION APPROXIMATE AND BASED ON A FIVE THREAD ENGAGEMENT.

Drawing 5678450

1600 Series Liquid Level Controllers

Dimensions

Dimensions in this catalog are for reference only. They may be changed without notice. Contact the factory for certified drawings for a particular model number. Dimensions are expressed as millimeters over inches (Linear = mm/in.)

1601 Standard Case Flanged Level Controller

ARM LENGTH	DIM E
15 INCH	407.8 16-1/16
18 INCH	484 19-1/16
20 INCH	534.8 21-1/16

DISPLACER	DIM C	DIM D
1.88 X 12 PVC	340.8 13-27/64	47.6 1-7/8
1.66 X 12 316SST	340.8 13-27/64	42.2 1-21/32
1.66 X 24 316SST	645.6 25-27/64	42.2 1-21/32

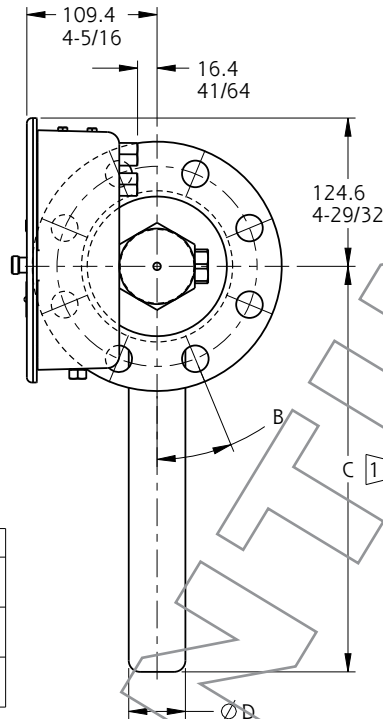

FLANGE	DIM A	DIM B
2" 150# RF	165.1 6-1/2	45°
2" 300# RF	173 6-13/16	22.5°
2" 600# RF	182.6 7-3/16	22.5°
2" 900# RTJ	204.7 8-1/16	22.5°
2" 1500# RTJ	204.7 8-1/16	22.5°
3" 150# RF	166.6 6-9/16	45°
3" 300# RF	171.5 6-3/4	22.5°
3" 600# RF	181.1 7-1/8	22.5°
3" 900# RTJ	246.1 9-11/16	22.5°
3" 1500# RTJ	261.9 10-5/16	22.5°
4" 150# RF	166.6 6-9/16	22.5°
4" 300# RF	174.8 6-7/8	22.5°
4" 600# RF	190.5 7-1/2	22.5°
4" 900# RTJ	258.8 10-3/16	22.5°
4" 1500# RTJ	271.5 10-11/16	22.5°
6" 150# RF	222.3 8-3/4	22.5°
6" 300# RF	233.4 9-3/16	15°
6" 600# RF	257.3 10-1/8	15°
6" 900# RTJ	270 10-5/8	15°
6" 1500# RTJ	303.3 11-15/16	15°

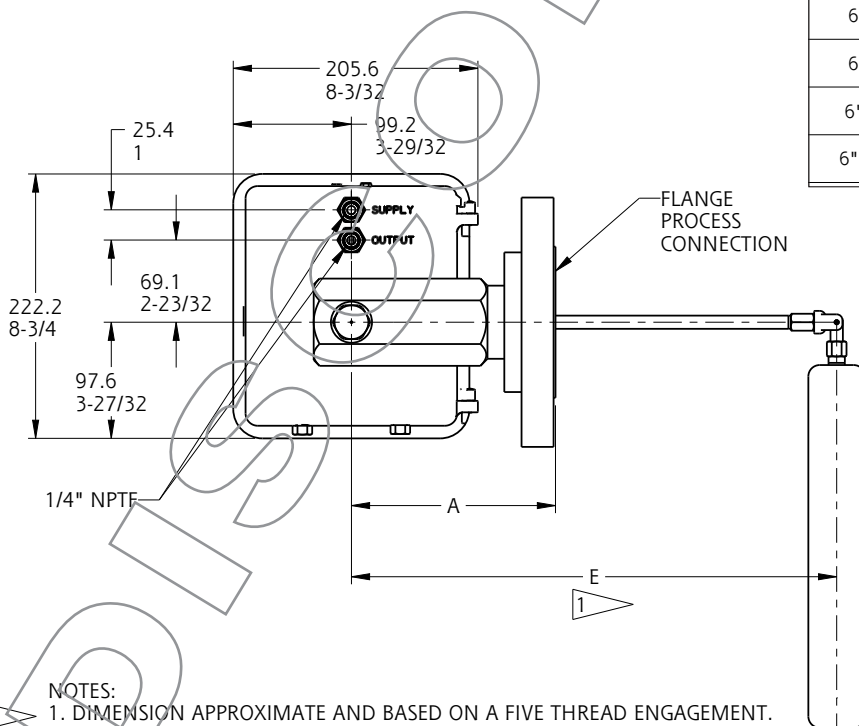

NOTES:
1. DIMENSION APPROXIMATE AND BASED ON A FIVE THREAD ENGAGEMENT.

Drawing 5678446

CONTINUED



MEASUREMENT AND CONTROL

SOR Inc. | Lenexa, KS USA | 913-888-2630 | Fax 913-888-0767 | SORInc.com

REGIONAL OFFICES

China

SOR China | Beijing, China | china@SORInc.com
+86 (10) 5820 8767 | Fax +86 (10) 58 20 8770

Middle East

SOR Measurement & Control Equipment Trading DMCC | Dubai, UAE
middleeast@SORInc.com | +971 4 363 3637 | Fax + 1 913 312 3596