



# 651 K9 RF Admittance Two Wire Point Level Control

## General Instructions

These instructions provide specific information for installation, electrical connection, calibration and troubleshooting for the 651 K9 RF Admittance Two-Wire Point Level Control.

**NOTE: If you suspect that a product is defective, contact the factory or the SOR® Representative in your area for a return authorization number. This product should only be installed by trained and competent personnel.**



### Pre-Installation I/O Test and Calibration

- ① Remove the housing cover.
- ② Place the instrument on an insulated surface or support so the sensor does not touch a conductive surface.
- ③ Apply 12 to 28VDC, and observe the LED. (See **A** on page 2)

**NOTE: When the LED is on, it indicates the output is in the normal state 16-20mA.**

- ④ Turn the sensitivity adjustment clockwise (up to 25 turns) to increase sensitivity until the LED goes out.

**NOTE: Do not turn the sensitivity adjustment past 25 turns! Damage to the unit could result.**

- ⑤ Turn the sensitivity adjustment counterclockwise to decrease sensitivity until the LED illuminates.

*Design and specifications are subject to change without notice.*

*For latest revision, go to **SORInc.com***

### Table of Contents

|  |       |
|--|-------|
| Pre-Installation I/O and Calibration ..... | 1-2   |
| Installation .....                         | 3     |
| Electrical Connections .....               | 4     |
| Post-Installation Calibration .....        | 4     |
| SOR RF Probe Grounding Screen .....        | 5     |
| Control Drawings .....                     | 6-9   |
| Instructions for EMC .....                 | 10    |
| Spare Parts .....                          | 10    |
| Information for IEC-Listed Product .....   | 10    |
| Maintenance and Troubleshooting .....      | 11    |
| Dimensions .....                           | 12-13 |
| ATEX and IECEx Marking Details .....       | 14    |
| Declaration of Conformity .....            | 15    |

- 6 Turn the sensitivity adjustment slowly clockwise until LED goes off, then counterclockwise until LED goes on to check the null position to verify that the bridge is balanced. It is desirable to closely bracket the position where the LED came on.
- 7 Turn the sensitivity adjustment one turn counterclockwise from the null position. Next, slowly move a hand toward the probe to touch it. The LED should stay on until the probe is touched. If it goes out when the hand is near, turn the sensitivity control counterclockwise so the LED stays on until the hand touches the probe. Usually, 1-2 turns will locate the new null point.

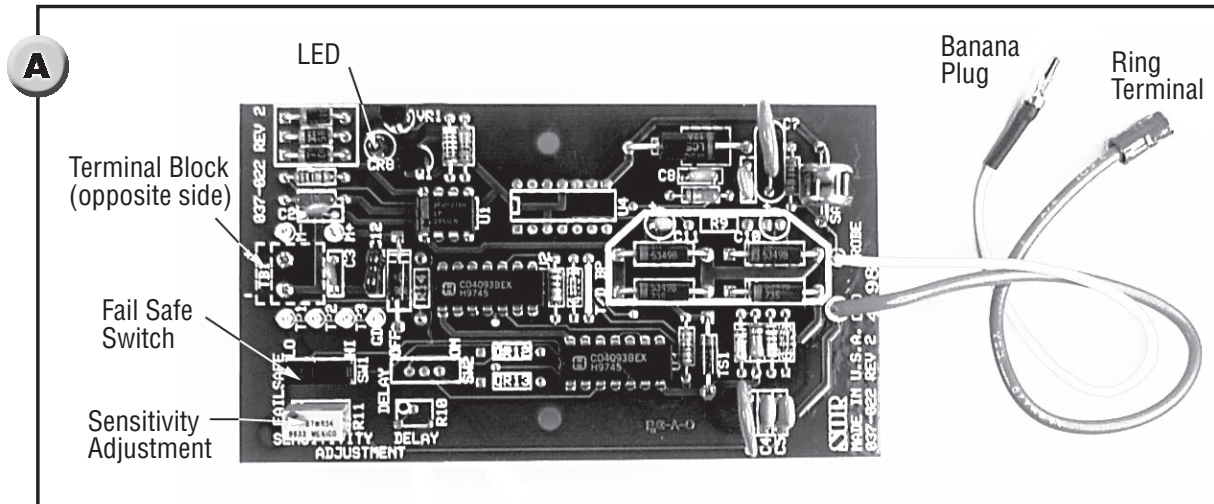

- 8 When practical, use a small container of actual process material to calibrate the control. If the actual process vessel is metal, use a metal container (coffee can, etc.) and ground it to the instrument housing. If the actual process vessel is an insulator, such as, fiberglass, use a plastic container.
- 9 Immerse the sensor in the process material; the LED should turn off. If not, rotate the sensitivity adjustment clockwise until the LED goes off.
- 10 To detect an interface, such as oil/water or foam/liquid, the lighter material must be in contact with the sensor, then tuned out. Then adjust the sensitivity to detect the heavier process material. (See **B** and **C**)

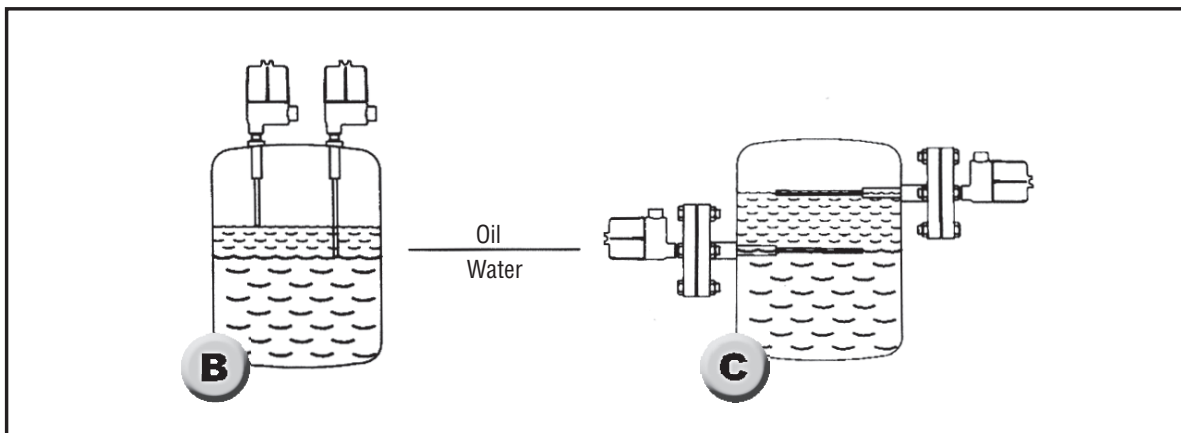

| Output Signal       |         |         |
|---------------------|---------|---------|
| Failsafe            | Hi      | Lo      |
| Absence of Process  | 16-20mA | 4-8mA   |
| Presence of Process | 4-8mA   | 16-20mA |

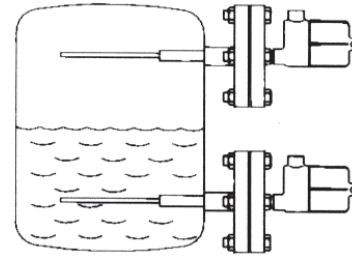

## Installation

**Standard configuration** is a 3/4" NPT(M) pipe nipple that threads into a 3/4" NPT(F) vessel nozzle or half coupling. Allow a 4" turn radius (See **E** and **F**). Sometimes open tanks, vats, sumps or basins require a locally-made bracket mount similar to that shown in. (See **I**).

**Optional configuration** is a raised face or flat face ANSI flange. See Form 1100 for selection. (See **G** and **H**)

**Orientation.** The control can be mounted in any position. Sensitivity is optimized when the greatest surface area of the sensor is parallel to the process level. (See **I** and **J**)

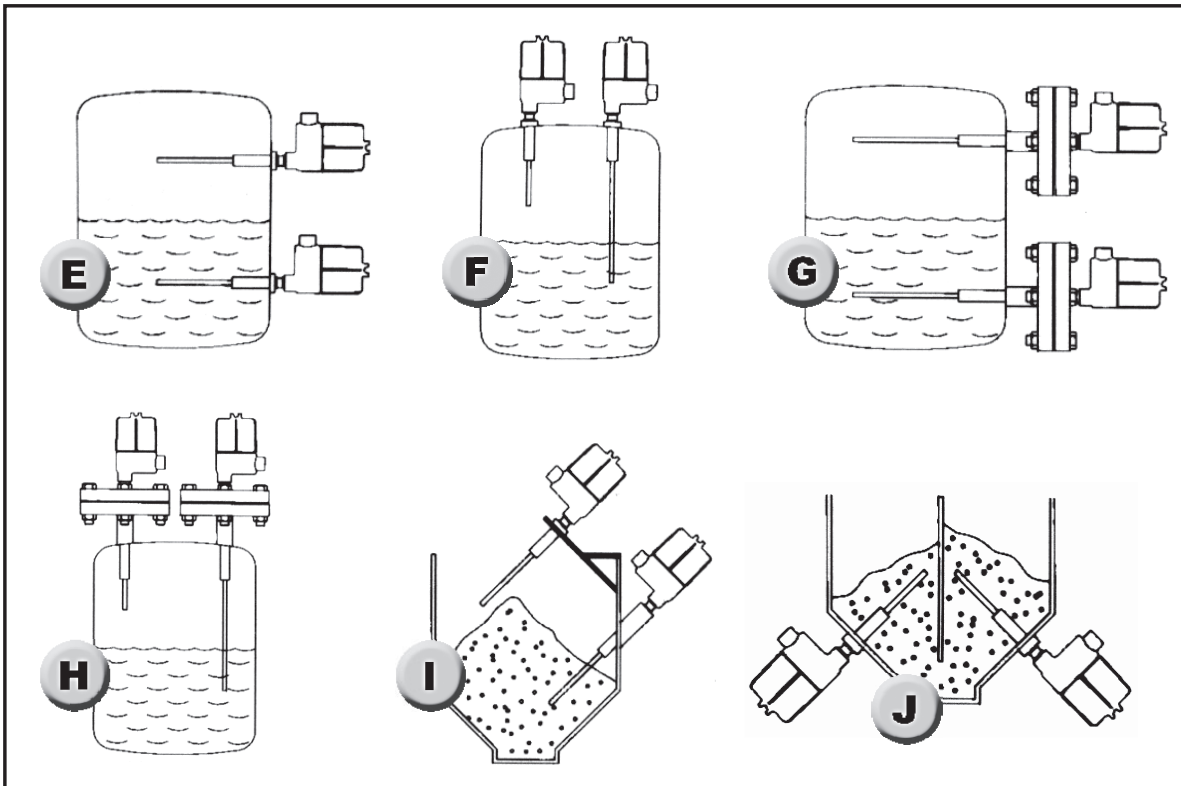

When the process is adhesive, i.e. it tends to coat the sensor, it may be desirable to mount it on a 45° angle to reduce product build-up and to increase its effective surface area. (See **I** and **J**)

Placement and orientation of the sensor in a vessel is frequently determined by available nozzles. The sensor should be away from fill points to avoid false trips. The insulator bushing on the sensor should protrude a minimum of 1" from the inner wall of the vessel. The sensor must not touch any metal, nor should conductive product build-up be allowed to bridge between the sensor and a grounded metal tank wall.



***This product must be installed with an explosion proof breather vent per Agency requirements and the National Electric Code-Article 501, Section F, paragraph 3.***

## Electrical Connections



***Electrical power must be disconnected from explosion proof/intrinsically safe models before the cover is removed. Failure to do so could result in severe personal injury or substantial property damage.***

- 1 Remove the housing cover. Ensure that all wiring conforms to all applicable local and national electrical codes and install unit(s) according to relevant national and local safety codes.
- 2 Connect the positive loop power wire to the terminal marked "+".
- 3 Connect the negative loop power wire to the terminal marked "-".
- 4 Replace the cover.
- 5 Apply power.

## Post-Installation Calibration



***Units in Hazardous Locations — Prior to calibration, make certain that the work area is declassified before removing the explosion proof cover to calibrate the unit. Failure to do so could result in severe personal injury and/or substantial property damage.***

- 1 Turn the set-point adjustment to the full clockwise position. The LED should be off (in Hi Level Fail-safe mode).
- 2 Turn the adjustment slowly counter-clockwise until the LED just changes state (on).
- 3 Raise the material level until it is above the sensing element. The LED should be off.
- 4 Turn the adjustment slowly counter-clockwise until the LED illuminates. Then turn the adjustment 1/2 turn clockwise (LED off) to complete the calibration.

# SOR RF Probe Grounding Scheme

Critical Grounding Path = ●.....●

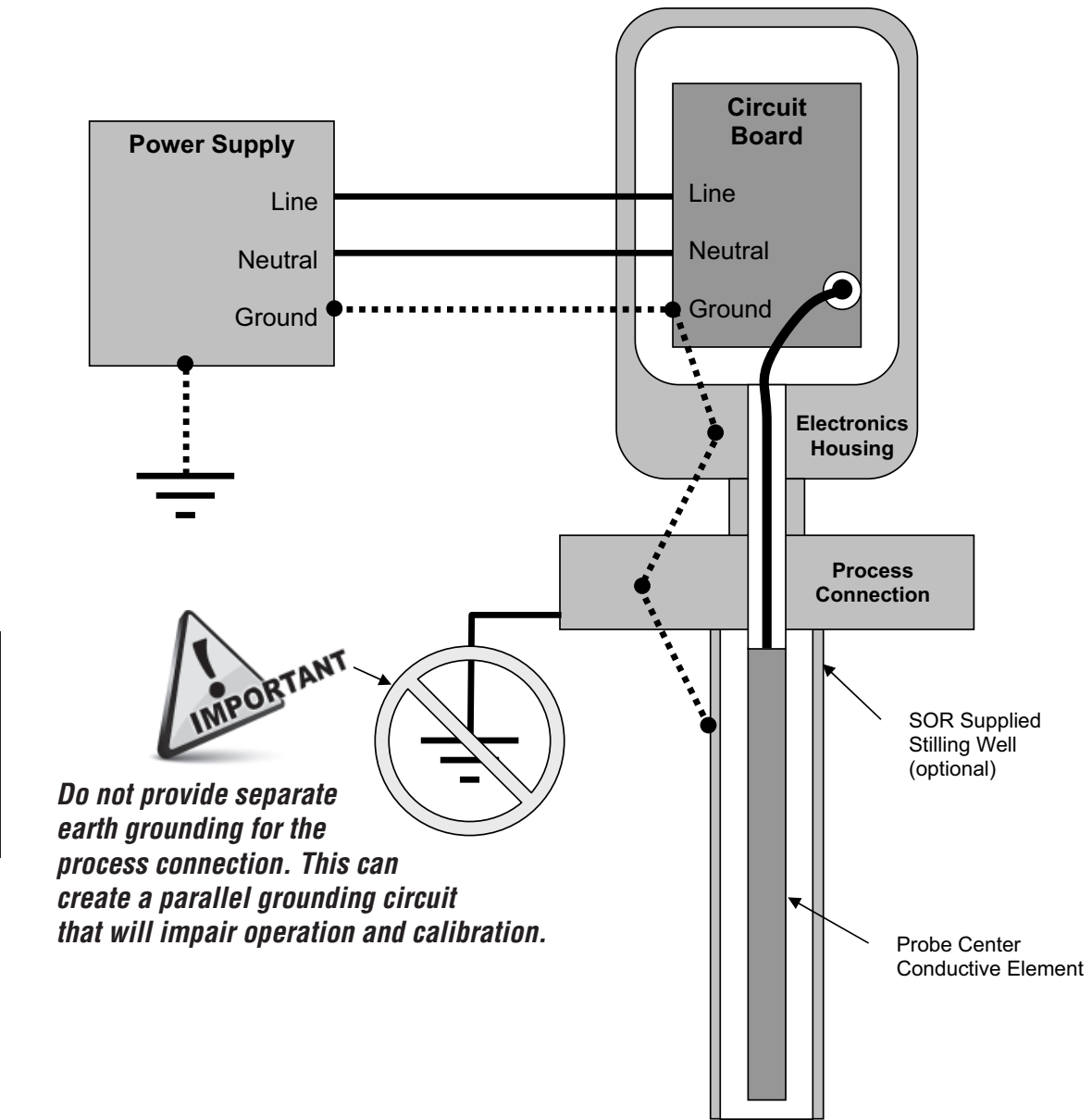



# Control Drawing



14685 West 105th Street Lenexa, Kansas 66215 USA  
Tel. 913-888-2630 Fax 913-888-0767

DRAWING NO. 9093-010

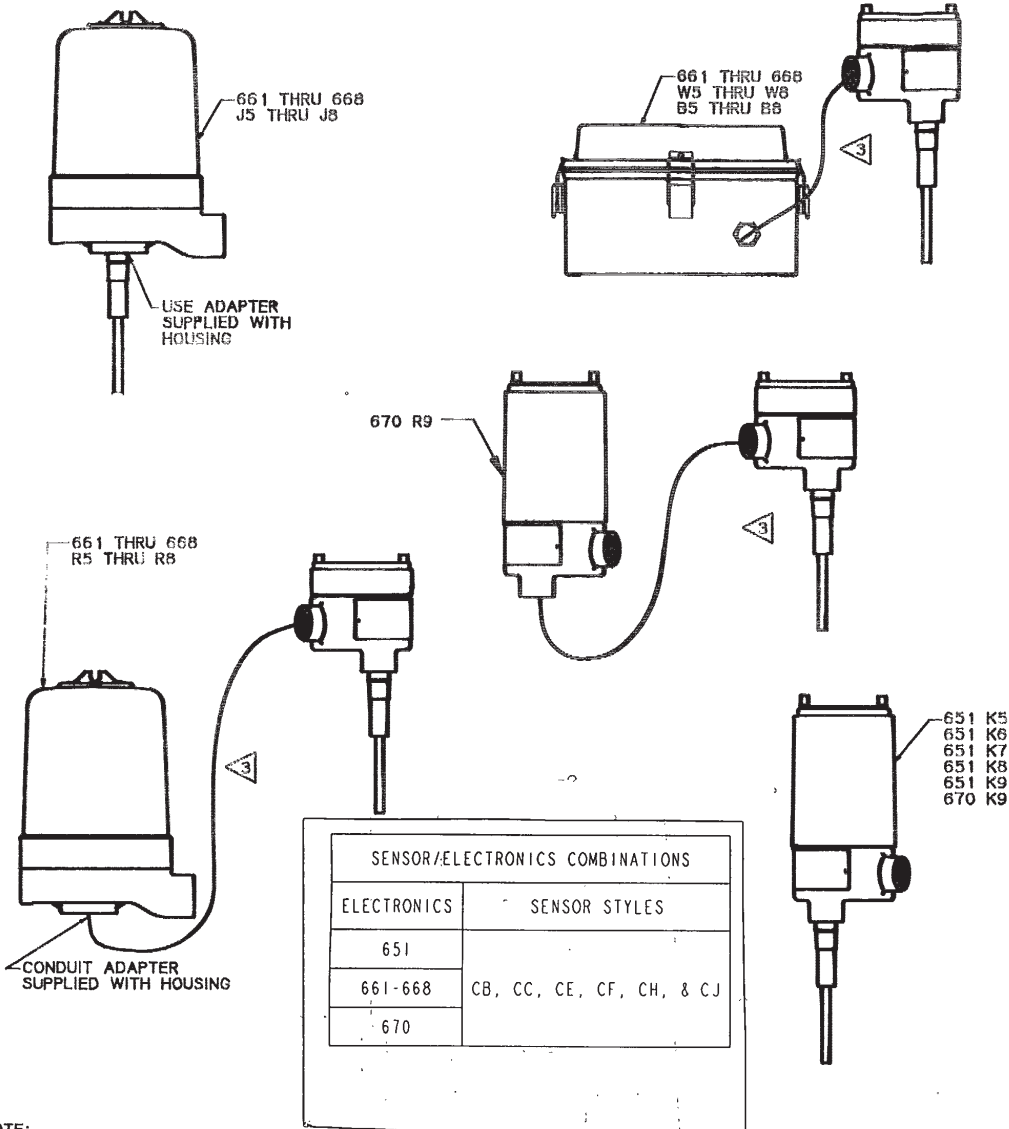

1 EO-3874 WBS  
 2 EO-4281 MLS  
 9/10/02 ABS

- NOTE:
- ONLY THOSE FMRC APPROVED SENSOR/ELECTRONICS COMBINATIONS LISTED ABOVE ARE VALID.
  - SENSOR/ELECTRONICS COMBINATION IS CERTIFIED FOR THE LESSER HAZARDOUS LOCATION RATING OF THE SENSOR OR THE ELECTRONICS HOUSING. FOR EXAMPLE THE ASSEMBLY OF A GROUP B SENSOR WITH A GROUP C HOUSING IS CERTIFIED FOR GROUP C.
  - WIRING SHALL BE INSTALLED IN COMPLIANCE WITH THE NATIONAL ELECTRIC CODE FOR HAZARDOUS (CLASSIFIED) LOCATIONS. SUITABLE LISTED SEAL FITTINGS SHALL BE INSTALLED WITHIN 18" OF EACH ENCLOSURE ENTRANCE.
  - A MINIMUM OF 5 FULL THREAD ENGAGEMENT BETWEEN ALL NPT THREAD JOINTS AND BETWEEN PROBE AND HOUSING CONNECTIONS IS REQUIRED PER NEC.

THIS DRAWING NOT TO BE CHANGED WITHOUT FM APPROVAL.

|   |   |             |                 |                         |          |
|---|---|-------------|-----------------|-------------------------|----------|
| TITLE<br>INSTALLATION DRAWING<br>FM RF EXPF PROBE/ELECTRONICS<br>COMBINATIONS |   | BY<br>WBS   | DATE<br>6/25/96 | DRAWING NO.<br>9093-010 | REV<br>2 |
| 1   | 2 | APPD<br>jnc | DATE<br>7/1/96  | SHEET<br>1              | OF<br>1  |

Drawing 9093010



# Control Drawing



14685 West 105th Street Lenexa, Kansas 66215 USA  
Tel. 913-888-2630 Fax 913-888-0767

DRAWING NO. 9093-011

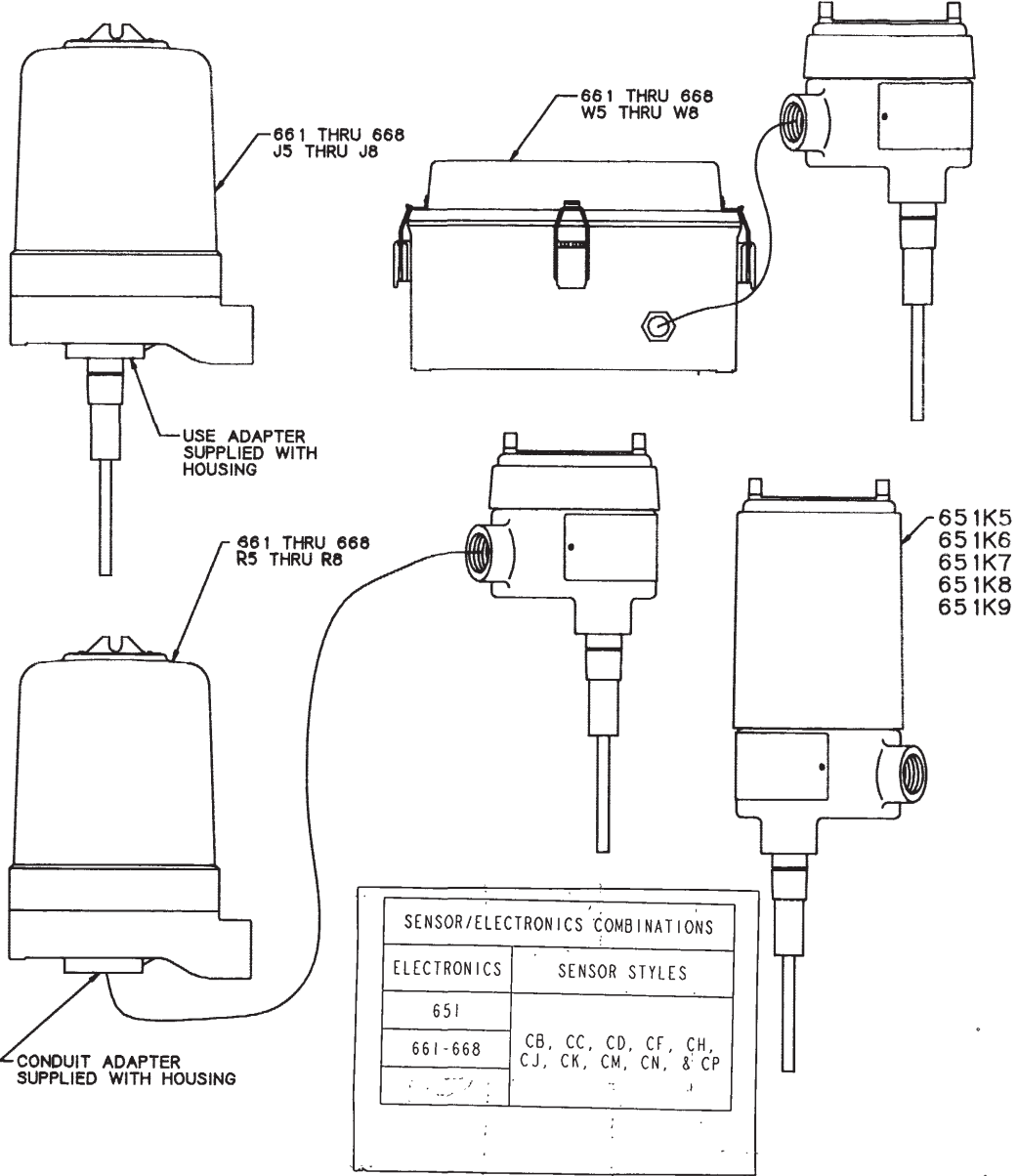

| SENSOR/ELECTRONICS COMBINATIONS |  |
|---------------------------------|--|
| ELECTRONICS                     | SENSOR STYLES                            |
| 651                             |  |
| 661-668                         | CB, CC, CD, CF, CH, CJ, CK, CM, CN, & CP |

- NOTE:
- ONLY THOSE SENSOR/ELECTRONICS COMBINATIONS LISTED ABOVE ARE VALID.
  - SENSOR/ELECTRONICS COMBINATION IS CERTIFIED FOR THE LESSER HAZARDOUS LOCATION RATING OF THE SENSOR OR THE ELECTRONICS HOUSING. FOR EXAMPLE THE ASSEMBLY OF A GROUP B SENSOR WITH A GROUP C HOUSING IS CERTIFIED FOR GROUP C.
  - WIRING SHALL BE INSTALLED IN COMPLIANCE WITH APPLICABLE CSA EXPLOSION PROOF STANDARDS FOR HAZARDOUS LOCATIONS.

THIS DRAWING NOT TO BE CHANGED WITHOUT CSA APPROVAL.

|   |         |        |         |     |    |
|---|---------|--------|---------|-----|----|
| 1 | EO-3812 | J. Wig | 9-6-96  | MLS | AD |
| 2 | EO-4281 | MLS    | 9/16/96 | AD  |    |

|  |  |             |                |                         |          |
|--|--|-------------|----------------|-------------------------|----------|
| TITLE<br>INSTALLATION DRAWING<br>CSA RF EXPF PROBE/ELECTRONICS<br>COMBINATIONS |  | BY<br>JWIG  | DATE<br>9-6-96 | DRAWING NO.<br>9093-011 | REV<br>2 |
|  |  | APPD<br>JAC | DATE<br>9-9-96 | SHEET<br>1              | OF<br>1  |

Drawing 9093011



# Control Drawing



14885 West 105th Street Lenexa, Kansas 66215 USA  
Tel. 913-888-2630 Fax 913-888-0767

DRAWING NO. 9093-009

## HAZARDOUS AREA

SERIES 651 K9 TRANSMITTER

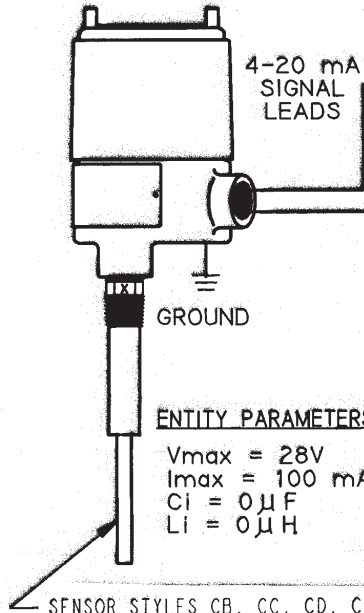

## SAFE AREA

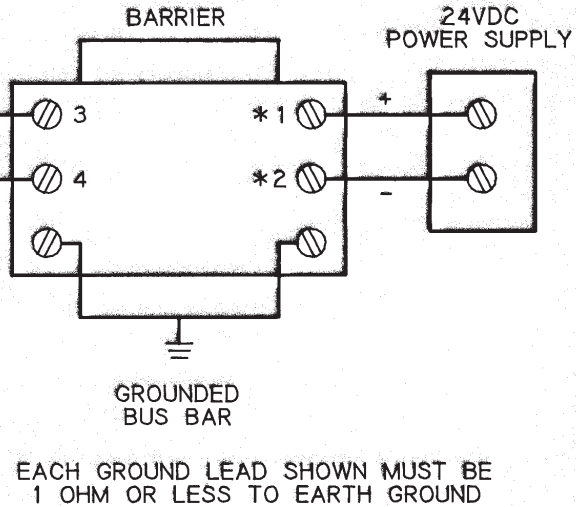

1. BARRIERS MUST BE INSTALLED IN ACCORDANCE WITH MANUFACTURERS INSTRUCTIONS.
2. BARRIER PARAMETERS MUST MEET THE FOLLOWING REQUIREMENTS:  
 $V_{oc} \leq V_{max}$                        $C_a \geq C_i + C_{Cable}$   
 $I_{sc} \leq I_{max}$                           $L_a \geq L_i + L_{Cable}$
3. MAXIMUM NON-HAZARDOUS AREA VOLTAGE MUST NOT EXCEED 250 V.
4. INSTALL IN ACCORDANCE WITH CANADIAN ELECTRICAL CODE, PART I.

Exia INTRINSICALLY SAFE/SECURITE INTRINSEQUE  
 WARNING: SUBSTITUTION OF COMPONENTS MAY IMPAIR INTRINSIC SAFETY.  
 ADVERTISSEMENT: LA SUBSTITUTION DE COMPOSANTS PEUT COMPROMETTRE LA SECURITE INTRINSEQUE

THIS DRAWING NOT TO BE CHANGED WITHOUT CSA APPROVAL.

|   |         |     |         |
|---|---------|-----|---------|
| 1 | EO-3812 |     |         |
| 2 | EO-4291 | MLS | 9/16/96 |

TITLE  
 CONTROL DRAWING CSA APPROVED  
 SERIES 651 K9 2 WIRE POINT  
 LEVEL CONTROL

BY  
*J Wig*  
 APPD  
*Jac*

DATE  
 09-16-96  
 DATE  
 9/16/96

DRAWING NO.  
 9093-009  
 SHEET 1 OF 1

REV  
 2

## Instructions for EMC

### 651K9

When subjected to an RF Interference, the 651K9 will maintain the  $\pm 1\%$  accuracy in all frequency ranges. In order to achieve the stated accuracy for the 651K9, a shielded cable, cable gland, shield bead and the probe should be mounted in a metallic vessel. SOR recommends using a shielded cable made of PVC Insulation around a tinned copper braid shield (Olflex CY cable or equivalent). Refer to illustrations for installation of shield bead onto the probe wire.

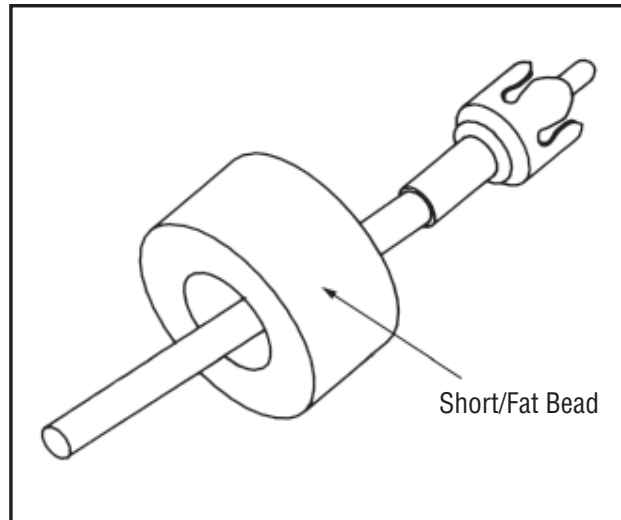

## Spare Parts

To order a new circuit board assembly, use the following part number: 99-414

**NOTE:** Replacement of circuit boards not allowed on agency listed units.

## Instructions for IEC-Listed Product

Certificate Number: IECEX BAS 05.0054X, Issue 2

Standards: IEC 60079-0:2011, Ed 6 and IEC 60079-11:2011, Ed 6

Listing: Ex ib IIB Tx Gb ( $-40^{\circ}\text{C} \leq T_a \leq +80^{\circ}\text{C}$ )

Parameters:  $U_i = 28\text{V}$

$I_i = 100\text{mA}$

$P_i = 0.75\text{W}$

$L_i = 0$

$C_i = 0$

Certificate Number: Baseefa 12ATEX0084X

Standards: IEC 60079-0:2011, Ed 6 and EN60079-11:2012

## Condition for Safe Use

- This apparatus may not be capable of withstanding the insulation test required by Clause 6.4.12 of IEC 60079-11:1999. This must be taken into account when installing the apparatus.
- The probes are coated with Teflon® and may present electrostatic risk. Clean only with a damp cloth.

## Troubleshooting

| Symptom/Problem  | Possible Cause  | Corrective Action  |
|--|---|--|
| LED stays illuminated, even at maximum sensitivity setting (full clockwise 25 turns).  | <ol style="list-style-type: none"> <li>Banana plug is loose or disconnected</li> <li>Probe lead is shorted to case or ground</li> <li>Faulty sensing circuit</li> </ol> | <ol style="list-style-type: none"> <li>Plug banana plug securely into sensor jack.</li> <li>Check that the bare end of the probe is not touching any metal part. Clean, repair or replace the sensor assembly.</li> <li>Call the factory.</li> </ol> |
| LED stays off, even at minimum sensitivity setting (full counter-clockwise, 25 turns). | No power to the circuit or excessive loop resistance.   | Check the voltage at the terminal block. It should be a minimum of 12V.  |
| Device will not detect process material.   | <ol style="list-style-type: none"> <li>Bad circuit switch</li> <li>The oscillator is not working</li> </ol>   | Call the factory.  |
| Calibration drifts   | <ol style="list-style-type: none"> <li>Sensitivity improperly set</li> <li>Highly conductive product</li> <li>Heavy conductive build-up on the sensor</li> </ol>        | <ol style="list-style-type: none"> <li>Recalibrate according to Post-Installation Calibration Instructions on page 3.</li> <li>Use sheather sensor.</li> <li>Use sheather sensor and periodically remove build-up.</li> </ol>                        |
| Corroded sensor  | Process material has chemically attacked sensor   | Use sheather sensor to provide corrosion resistance.   |
| Eroded or abraded sensor   | Fast flowing or agitated process has physically attacked sensor.  | Consider other sensor material or design, relocating sensor or a stilling well in liquid process.  |
| Output current exceeds 23 mA   | Bad current switch  | Call the factory.  |
| Output current is below 3.5 mA   | The oscillator is not working.  | Call the factory.  |

**NOTE: Agency certified units, (FM, CSA, IEC) must be returned to SOR for repairs.**

## Dimensions - K Housing Configuration (Explosion Proof Integral)

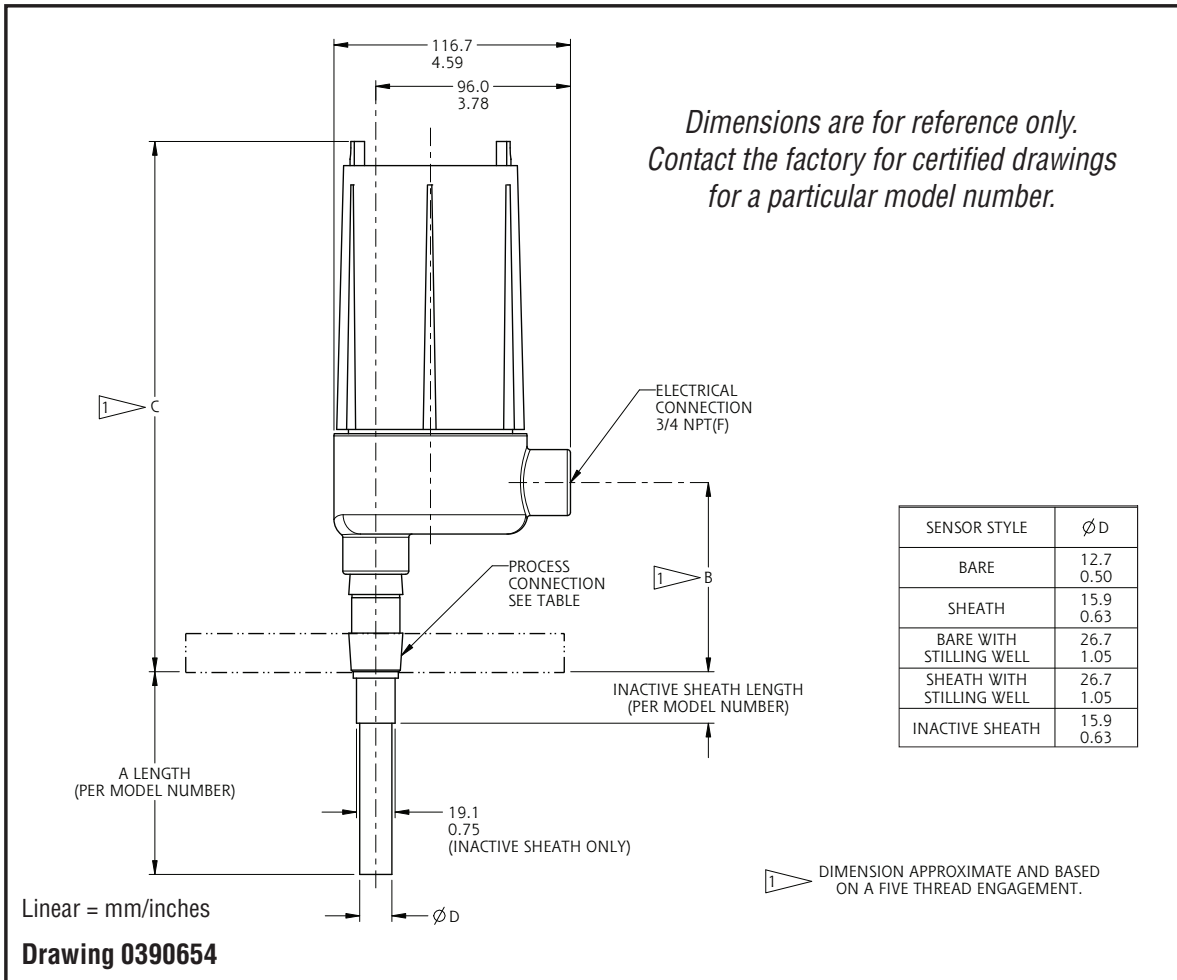

| Process Connection    | Dim B                |                      | Dim C                 |                       |
|-----------------------|----------------------|----------------------|-----------------------|-----------------------|
|                       | Cable Probe          | All Other Probes     | Cable Probe           | All Other Probes      |
| 3/4" NPT(M)           | <u>87.8</u><br>3.46  | <u>94.1</u><br>3.71  | <u>256.0</u><br>10.08 | <u>262.4</u><br>10.33 |
| 1, 1-1/2, & 2" NPT(M) | <u>99.7</u><br>3.92  | <u>97.3</u><br>3.83  | <u>268.0</u><br>10.56 | <u>265.6</u><br>10.46 |
| Flanged               | <u>158.5</u><br>6.24 | <u>158.5</u><br>6.24 | <u>326.8</u><br>12.87 | <u>326.8</u><br>12.87 |
| Stilling Well         | N/A                  | <u>120.0</u><br>4.72 | N/A                   | <u>288.3</u><br>11.35 |

# Dimensions - K Housing Configuration (Explosion Proof Integral)

## Dual Rigid Probe Detail

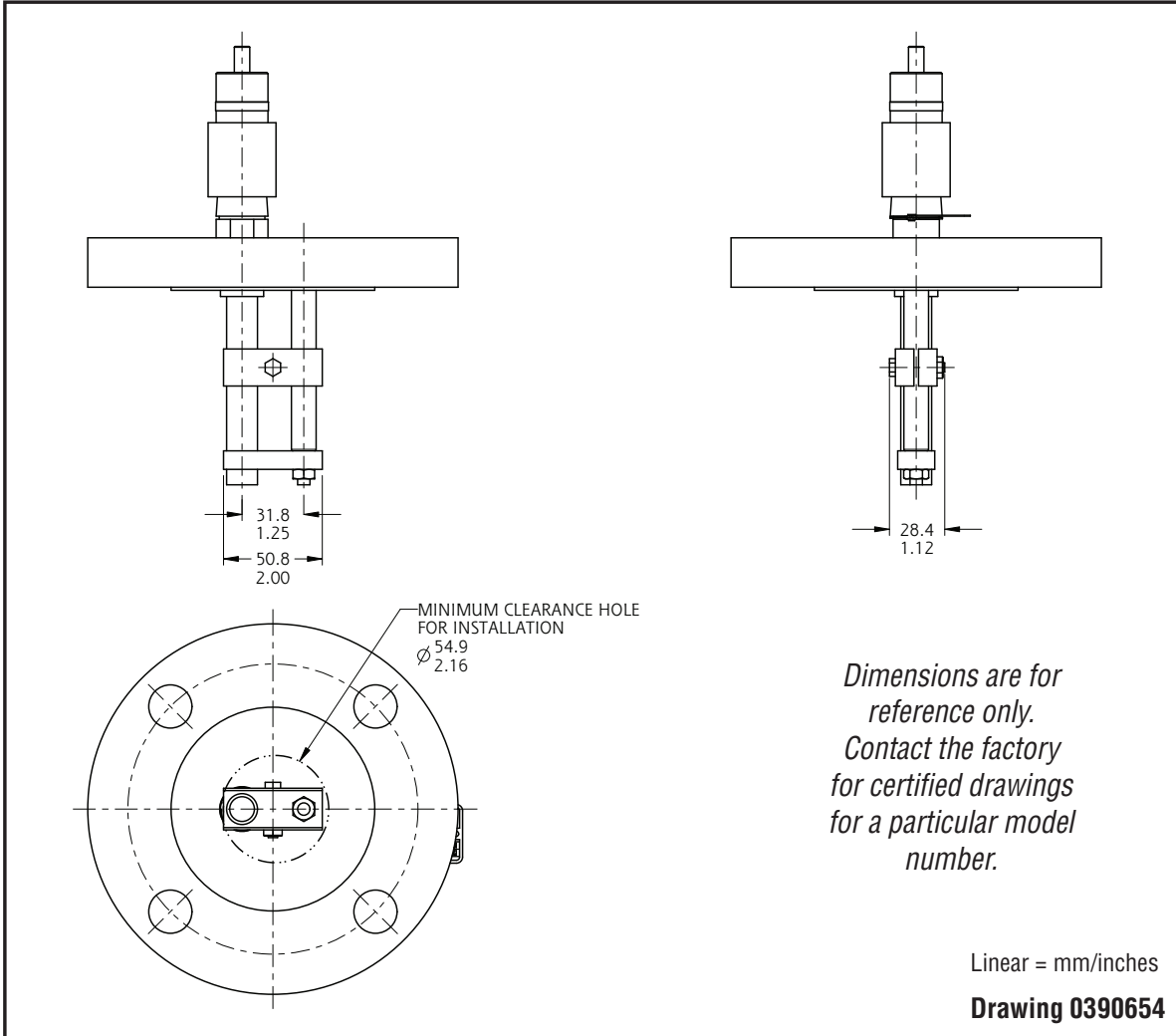

# General Information for ATEX Certified Models

## Sample Nameplates

Drawing 8924119

Manufacturer's Registered Trademark

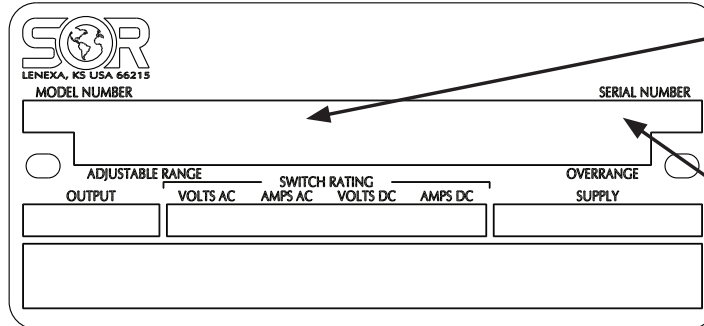

Location of Product Model Identification

Location of Serial Number (First Two Numbers Indicate Year of Manufacture)

Drawing 0720527

Manufacturer's Registered Trademark

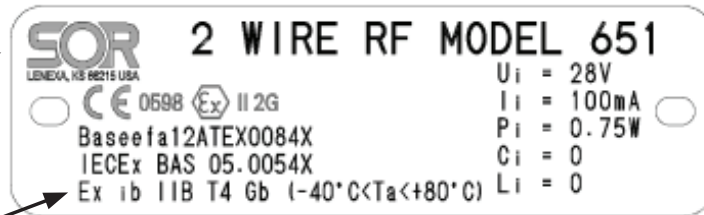

Location of ATEX Listing Information

# Declaration of Conformity

For ATEX Certified Models

## EU Declaration of Conformity

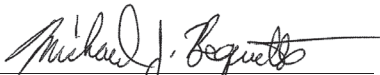

|  |   |
|--|---|
| <b>Product</b>   | <b>2 Wire RF Admittance Transmitter Model 651</b>   |
| <b>Manufacturer</b>  | SOR Inc.  |
| <b>Place of Issue</b>  | 14685 West 105 <sup>th</sup> Street<br>Lenexa, Kansas 66215-2003<br>United States of America  |
| <b>Date of Issue</b>   | <b>June 18, 2020</b>  |
| <b>We declare under our sole responsibility that the above products conform to the following specifications and directives</b> | ATEX Directive (2014/34/EU) Equipment Intended for use in Potentially Explosive Atmospheres<br>EN 60079-0:2018 IEC 60079-0:2017<br>EN 60079-11:2012 IEC 60079-11:2011 |
| <b>Carries the marking</b>   |  <b>II 2G Ex ib IIB T4 Gb</b> (-40°C ≤ Ta ≤ +80°C)                                   |
| <b>Reference document</b>  | <b>EC-Type Examination Certificate</b><br><b>Baseefa 12ATEX0084X</b> Issued October 2, 2012<br><b>IECEX BAS 05.0054X</b> Issued August 16, 2005                       |
| <b>ATEX Notified Body</b>  | <b>SGS Fimko Oy</b> (Notified Body No. 0598)<br>Takomotie 8<br>Helsinki, 00380<br>Finland   |
| <b>Person responsible</b>  | Michael J. Bequette (VP of Engineering)   |

  
Michael J. Bequette

**Engineered to Order with Off-the-Shelf Speed**

 14685 West 105th Street, Lenexa, KS 66215-2003  
913-888-2630 • 800-676-6794 USA • 913-888-0767 FAX

Form 1384 (06.20) ©SOR Inc.





14685 West 105th Street, Lenexa, KS 66215 ■ 913-888-2630 ■ 800-676-6794 USA ■ [SORInc.com](http://SORInc.com)