



Multifpoint Electronic Level Detector

General Instructions

The Multipoint Electronic Level Detector is a level sensing device which reads process level by capacitance measurement.

Capacitance varies according to the height of the process inside the vessel.

Capacitance variation in the circuit is electronically monitored, and DPDT relay contacts change state at user selected set points to signal process presence at specific process levels.

For example, when process level rises to set point 4, relay 4 changes state to signal process presence at set point 4. The DPDT relay 4 maintains its state as long as process level is above set point 4. When process level falls below set point 4, relay 4 contacts return to their original state.

NOTE: If you suspect that a product is defective, contact the factory or the SOR® Representative in your area for a return authorization number (RMA). This product should only be installed by trained and competent personnel.

Table of Contents

Sensing Level Configuration	2
Adjustable Differential Set Points	2
Setup	3
Probe Installation	3
Installation of Separate Electronics Housing ...	3
Remote Cable Connection	3
Electrical Supply/Control Cable Connection	4
Probe Setup Overview and Considerations	6
Probe Tip Termination Notes	7
Actual Level Setup	8
Calculated Setup	9
Calculated Setup Worksheet Sample	13
Model 661 Set pt. Setup and Output Wiring ..	14
Model 662 Set pt. Setup and Output Wiring ..	16
Model 663 Set pt. Setup and Output Wiring ..	18
Model 664 Set pt. Setup and Output Wiring ..	20
Model 665 Set pt. Setup and Output Wiring ..	22
Model 666 Set pt. Setup and Output Wiring ..	24
Model 667 Set pt. Setup and Output Wiring ..	26
Model 668 Set pt. Setup and Output Wiring ..	28
Control Drawings	31
Dimensions	33

Design and specifications are subject to change without notice.

For latest revision, go to www.sorfinc.net

Sensing Level Configuration

The number of set points and their configuration depends upon the model number specified for manufacture. Compare the first three numbers from the nameplate model number to **A** to find the sensing level configuration for the unit to be installed.

Models 661 through 664 provide fixed, narrow differential set points only. For each fixed differential set point, relay operation is centered on a single point. After setup, the single point of relay operation can be set anywhere on the probe by adjusting the appropriate set point potentiometer (pot).

Adjustable Differential Set Points

Models 665 through 668 include an adjustable differential set point. For the adjustable differential set point, the adjustable differential relay is controlled by two limits. The adjustable differential relay changes state when process level reaches the upper limit of the adjustable differential set point.

The adjustable differential relay maintains its state until process level falls below the lower limit of the adjustable differential set point. When process level falls below the lower limit of the adjustable differential set point, the adjustable differential relay contacts return to their original state.

The upper limit can be set anywhere on the probe by adjusting potentiometer (pot)
2. The lower limit can be set anywhere on the probe by adjusting potentiometer (pot)
3. The adjustable differential set point provides a single set of contacts to control cut—in and cut—out of filling (or emptying) equipment.

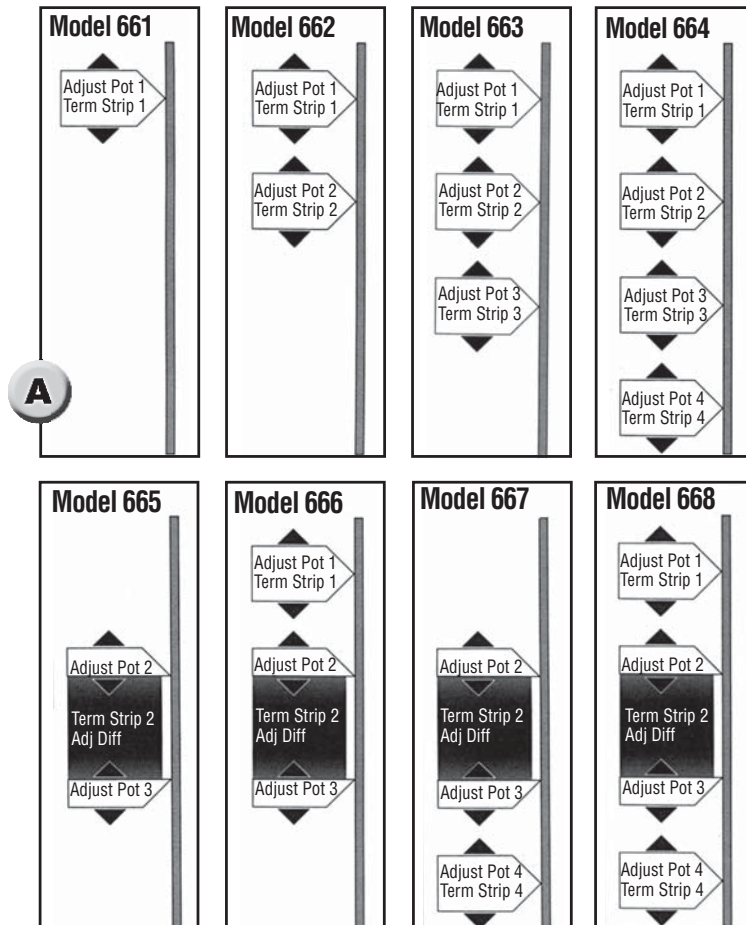

Model 666 through 668 sensing level configurations provide an adjustable differential set point for vessel level control as well as one or two fixed differential set points for Hi—Hi and Lo—Lo level alarm or shutdown circuits.

Setup

Review Probe setup overview and considerations on page 6 to determine the best approach to setup. Two setup methods are possible. Actual Level setup begins in the right column on page 8. Calculated Level setup begins in the left column on page 9.

Review both methods. Actual Level setup is preferred, but may not be practical for all installations.

Probe Installation

All models

Probes are mounted vertically from the top of a vessel. The probe must be electrically isolated from the vessel; make no connection between the probe and the vessel other than the process connection and (if applicable) the threaded weight at the probe tip. Do not weld any part of this instrument.

Make sure that the sensor can be fully inserted and tightened without interference from obstructions inside the tank or vessel. (See **B**) The probe should be mounted away from inlet fill paths. Spray from a fill path can cause false level indications.

- Insert coated probes carefully to prevent damage to the probe coating.
- For pressurized vessels, seal the flanged or threaded process connection to prevent leakage.
- Do not use the sensor base as a handle to tighten a threaded process connection.
- Use a suitable wrench on the flats to tighten a threaded probe into the process connection.
- Use suitable mounting bolts to mount a flanged probe on a flanged process connection.

Installation of Separate Electronics Housing

Explosion Proof Electronics Housing (Model 66□R)

The explosion proof electronics housing can be line mounted. Alternatives to line mounting are surface mounting or pipe mounting if appropriate accessory hardware was specified.

Weathertight Electronics Housing (Model 66□W)

The weathertight electronics housing can be surface mounted using #10 or M6 bolts through the mounting pads. Recommended mounting orientation is horizontal with cover hinges at 12 o'clock. Allow headroom for cover swing.

Remote Cable Connection

Models 66□R, 66□W

Install conduit between the remote probe housing and the separate electronics housing. In order to maintain explosion proof ratings in hazardous areas, the conduit system must meet or exceed any explosion proof requirements for the location.

Fish 22/2 shielded twisted pair signal cable through the conduit between the housings.

The terminal block on the set point adjustment board (in the electronics housing) must be connected to the terminal block on the probe adjustment board (in the remote probe housing). (See **C**)

Connect the shield to GND on the set point adjustment board and on the probe adjustment board.

Connect the +12 terminal on the set point adjustment board to the +12 terminal on the probe adjustment board.

Connect the SIG terminal on the set point adjustment board to the SIG terminal on the probe adjustment board. (See **C** detail.)



Electrical power must be disconnected from explosion proof models before the cover is removed. Failure to do so could result in severe personal injury or substantial property damage.

Ensure that wiring conforms to all applicable local and national electrical codes and install unit(s) according to relevant national and local safety codes.

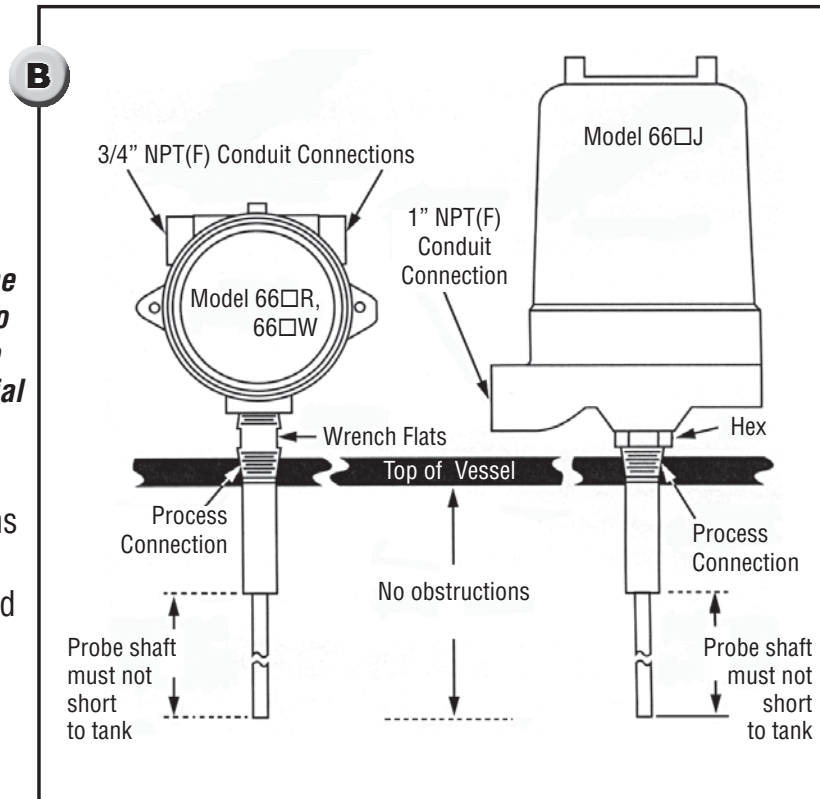

Electrical Supply / Control Cable Connection

Model 66□J

Install conduit and fish cables to carry supply and control conductors into the integral housing.

Models 66□W, 66□R

Install conduit and fish cables to carry supply and control conductors into the separate electronics housing.

All Models

A three-position terminal strip located on the power supply/relay output board provides connections for Line Power and Ground. Terminal positions are labeled on the circuit board as shown in the **D** detail.

Make sure that field power matches the instrument's power requirements. The fifth place designator in the nameplate model number specifies power requirement. (See **E**) Make connections to +/L1 and -/L2/Neutral terminals according to **E**.

The housing and the PC Board must be connected to ground. Ground (earth) screws are provided on the three-position PC board terminal strip and on the housing floor. Control Cable connection is detailed later in these instructions, after probe setup and set point adjustment.



This product must be installed with an explosion proof breather vent per Agency requirements and the national Electric Code- Article 501, Section F, paragraph 3.

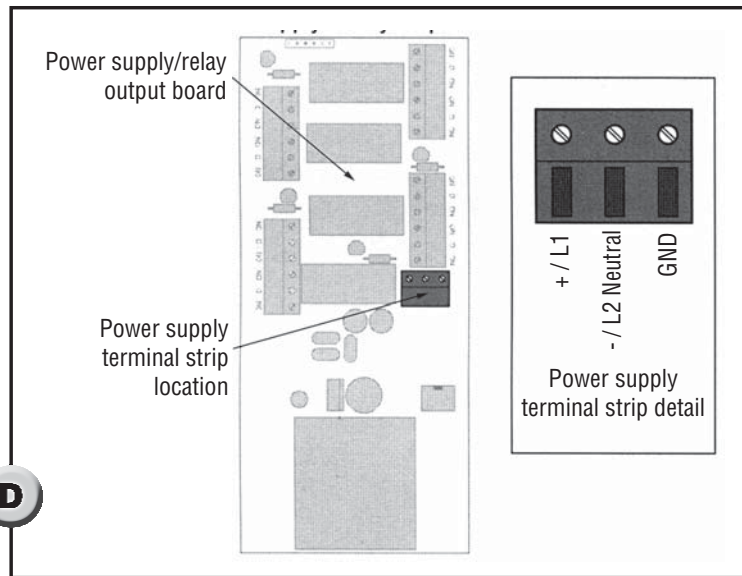
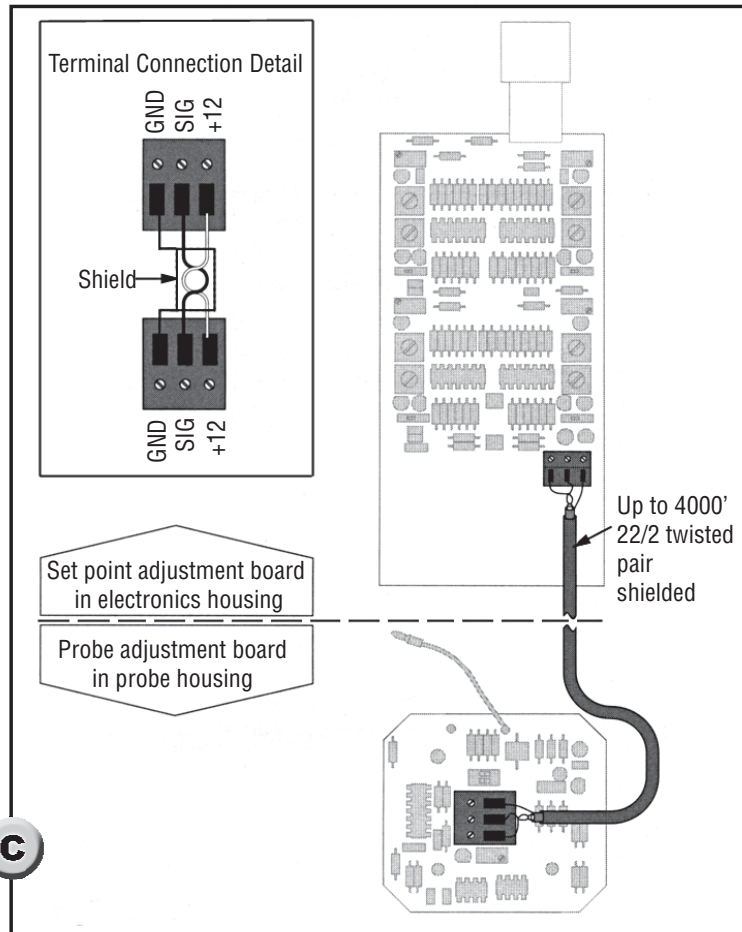

Fifth Place Designator or 6 6 □ □ □	Power Supply Requirement	Maximum Current Draw	Terminal +/L1 Connection	Terminal +/L2 Neutral Connection
E 5	12 VDC \pm 10%	245 ma	12 VDC+	12 VDC Gnd
6	24 VDC \pm 10%	243 ma	24 VDC+	24 VDC Gnd
7	24 volt \pm 10%	74 ma	Line	Neutral
8	24 volt \pm 10%	36 ma	Line 1	Line 2

Probe Setup Overview and Considerations

If the process can easily be raised and lowered during setup, use the Actual Level Setup procedure. During Actual Level Setup, the process must be positioned to maximum level and to each set point level as briefly outlined in **F**. Begin the Actual Level Setup procedure on page 8.

If the process cannot easily be raised and lowered during setup, use the Calculated Setup procedure. During Calculated Setup, picofarad readings are taken at two levels. The readings are used to calculate the picofarad value for maximum level as well as the picofarad value for each set point level. Begin the Calculated Setup Procedure on page 9.



Units in Hazardous Locations — *Prior to calibration, make sure that the work area is declassified before removing the explosion proof cover to calibrate the unit. Failure to do so could result in severe personal injury or substantial property damage.*

The Actual Level Setup procedure and the Calculated Setup procedure are designed to yield maximum set point adjustability. In both procedures (Actual Level Setup and the Calculated Setup), the active area of the probe is spanned to maximum process level. (Step 1 **F**) When the span is set to maximum vessel level, set point adjustability is unlimited up to maximum vessel level (**H**).

By spanning the probe only as high as the uppermost set point level (instead of maximum level - see **I**), set point adjustability is restricted, but set point resolution is optimized.

To modify the Actual Level Setup procedure for optimal resolution, set the threshold for probe span and the threshold for the uppermost set point while the process is steady at the uppermost set point level. (See modification to Step 1 **G**)

To modify the Calculated Setup procedure for optimal resolution, use the picofarad value for the uppermost set point as the picofarad value for maximum level.

H and **I** illustrate the effect of span on resolution. Note on **I** that set points cannot be positioned above the uppermost set point. If future requirements call for a set point that is higher than the current uppermost set point, the probe will have to be re-spanned to the new uppermost set point level (or to maximum level).

Probe Tip Termination Notes

For sheath probes, the last inch of the rigid probe is inactive.

The flexible probes terminate with inactive 316SS weights. The weights are insulated from the probe, and 3/4-16 UNF threads are provided for connection to locally provided anchoring hardware.

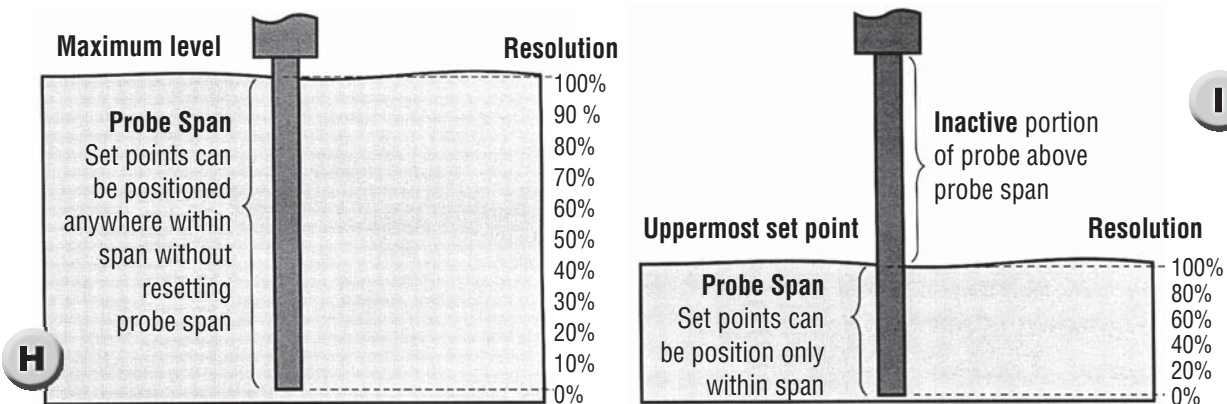
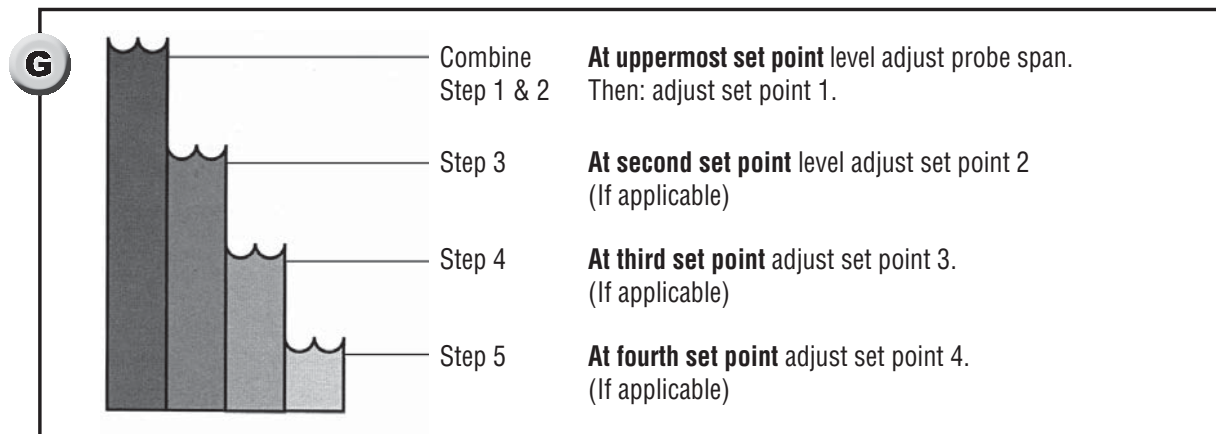
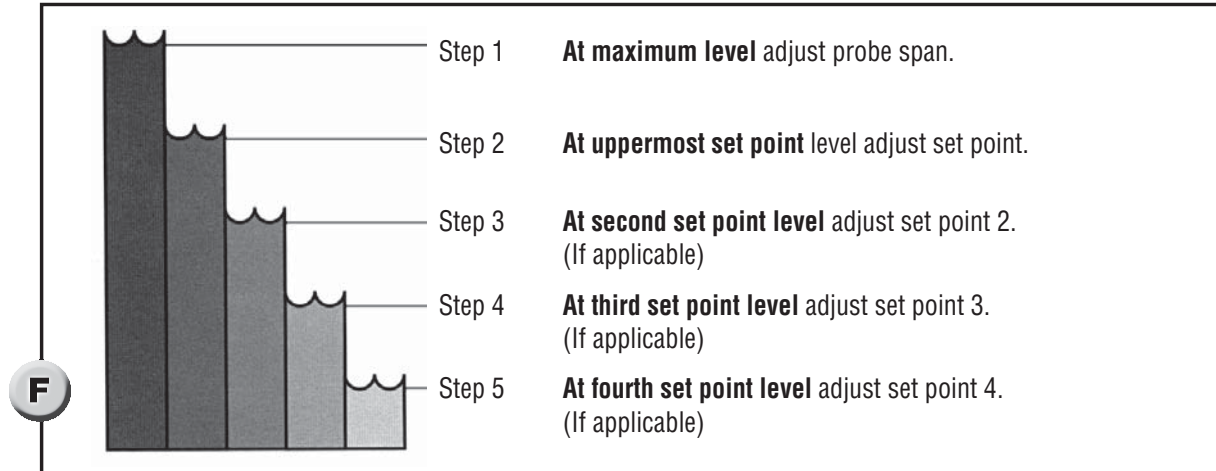

Actual Level Setup

For Actual Level Setup, the process must be positioned to maximum level to set the probe span. The process is then lowered to each set point in turn, and at each stop the appropriate set point threshold is adjusted.



Units in Hazardous Locations — Prior to calibration, make sure that the work area is declassified before removing the explosion proof cover to calibrate the unit. Failure to do so could result in severe personal injury or substantial property damage.

See **J** to locate adjustments when setting up a remote mounted probe. See **K** to locate adjustments when setting up an integrally mounted probe. (If process level cannot be raised to maximum level or conveniently moved to desired set point levels, use the Calculated procedure on next page.) Before starting the Actual Level procedure, make sure that the following steps have been completed.

SPAN ADJUST

- Instrument installed with power applied.
- Process steady at maximum level.
- Probe span pot fully CCW (twenty five turns CCW).
- Turn all set point adjust pots fully CCW (25 turns CCW).
- Turn all on and off delay pots fully CCW (One turn pots).
- Set all failsafe detectors to LO position.
- Both range selection DIP detectors off (open).

Watch the probe loading LED:

- ① LED is on — close DIP detector1 and go to step 2.
LED is off — go to step 3.
- ② LED is on — close DIP detector 2 and go to step 3.
LED is off — go to step 3.
- ③ Turn the span pot CW until the probe loading LED lights, and then CCW to the point where the LED goes off.

Slowly cycle the process up and down to verify the stability at which the LED goes off (per your requirement).

SETPOINT ADJUST

Lower process to set point 1 level (set point 1 removed for model 665 & 667) and continue on the page which matches the first three digits of the model number.

661.....p. 14	662..... p. 16	663p. 18	664 p. 20
665.....p. 22	666..... p. 24	667p. 26	668 p. 28

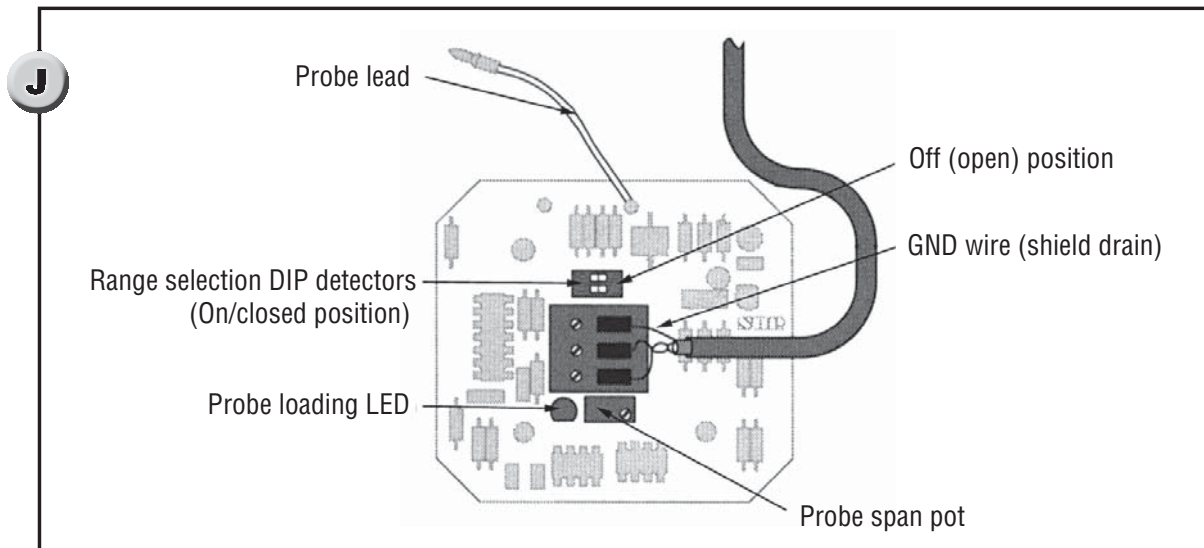

Calculated Setup

For Calculated setup, the capacitor substitution box is used to determine the picofarad value of the process at two levels (A & B in the example **L**). Subsequent calculations provide the rest of the values required for complete setup. See **J** to locate adjustments when setting up a remote mounted probe. See **K** to locate adjustments when setting up an integrally mounted probe.

Level A must be separated from level B by at least 5% of the length to be sensed. (At least 5% of 30' in the example.)



Units in Hazardous Locations — Prior to calibration, make sure that the work area is declassified before removing the explosion proof cover to calibrate the unit. Failure to do so could result in severe personal injury or substantial property damage.

Conditions required to begin Calculated setup:

- Instrument installed with power applied.
- Process steady at Level A (10' in the example **L**).
- Span pot fully CCW (25 turns CCW).
- Both range selection DIP detectors off (open).

A sample worksheet is shown on page 13. The sample is filled out according to conditions outlined in **L**. Level A must be greater than Level B for proper worksheet calculation. Any unit of measure can be used with the Calculated Worksheet.

- Enter the measurement for maximum level on line 8 of the worksheet.
- Enter the value for level A on line 1 and the value for level B on line 2 of the Calculated Worksheet.

Set Threshold for Level A

Watch the probe loading LED:

- 1 LED is on — close DIP detector 1 and go to step 2.
LED is off — go to step 3.
- 2 LED is on — close DIP detectors 1 & 2 and go to step 3.
LED is off — go to step 3.
- 3 Turn the span pot CW until the probe loading LED lights, and then CCW to the point where the LED goes off.

Slowly cycle the LED on and off as required to find the precise threshold at which the LED goes off. The instrument is now tuned to the picofarad value for Level A.

Find Picofarad value for Level A

For Models 66□R, 66□W Refer to **J**.

The probe is replaced by the capacitor substitution box to determine the picofarad value for level A.

Remove three #6 Torx head screws and pull the PC board out of the remote probe housing.

Unplug the probe lead wire from the probe.

To place the capacitor substitution box into the circuit, clamp one of the alligator clips to the mini-banana plug on the end of the probe lead wire. Clamp the other alligator clip to the shield drain wire (ground) as it enters the signal cable terminal strip.

For Models 66□J

Refer to **K**.

Pry the spring steel PC board retaining clip off of the top of the PC bracket assembly.

Unplug the ribbon connector and slide the set point adjustment board up to access the probe lead wire. Unplug the probe lead wire from the probe. Plug the ribbon connector back in.

Clamp one of the alligator clips to the mini-banana plug on the end of the probe lead wire. Clamp the other alligator clip to the ground screw on the housing floor.

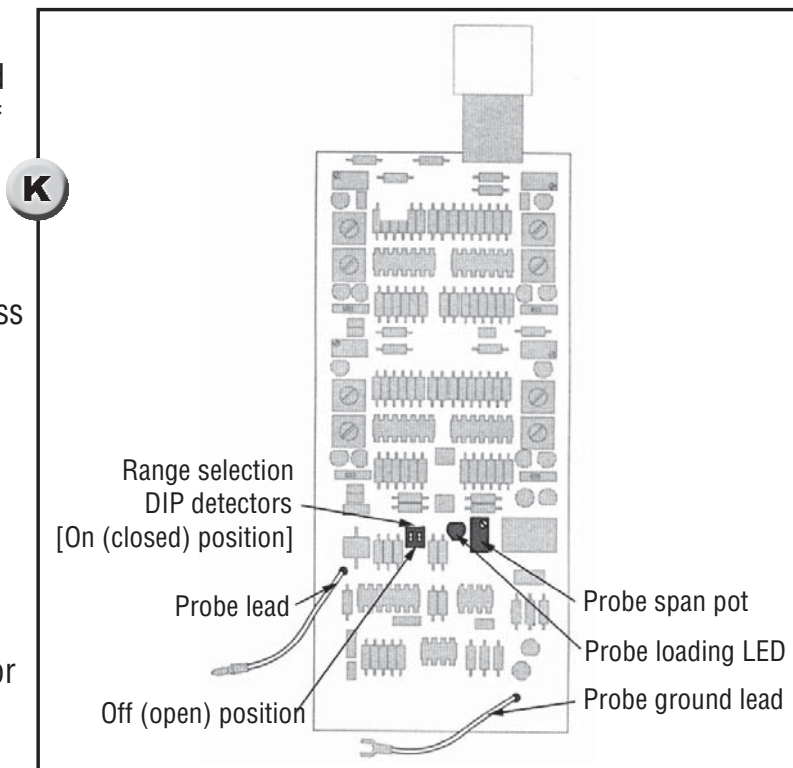

All Models

The capacitor substitution box will inject capacitance, emulating the probe.

Using the thumbwheels on the capacitor substitution box, gradually increase the injected capacitance until the probe loading LED lights.

Note the value on the substitution box thumb wheels when the probe loading LED lights; record that value on line 4 of the worksheet. The recorded value is the picofarad value for level A (2200 pf on page 12).

Take the alligator clip off of the probe lead, and plug the probe lead back into the probe.

Lower the process to Level B, and turn both DIP detectors off (open).

Set Threshold for Level B Watch the probe loading LED:

- ❶ LED is on — close DIP detector 1 and go to step 2.
LED is off — go to step 3.
- ❷ LED is on — close DIP detectors 1 & 2 and go to step 3.
LED is off — go to step 3.
- ❸ Turn the span pot CW until the probe loading LED lights, and then CCW to the point where the LED goes off.

Slowly cycle the LED on and off as required to find the precise threshold at which the LED goes off. The instrument is now tuned to the picofarad value for Level B.

Find Picofarad Value for Level B

Unplug the probe lead from the probe. Clamp the alligator clip to the mini-banana plug on the end of the probe lead wire. (The other alligator clip should still be clamped to ground.)

Gradually increase the injected capacitance until the probe loading LED lights.

Note the value on the substitution box thumb wheels when the probe loading LED lights; record that value on line 5 of the worksheet. The recorded value is the picofarad value for level B (1900 pf on page 12).

Using the picofarad values for A and B, the picofarad per foot value can be interpolated, and the picofarad value for maximum level can be extrapolated as shown in . Complete the worksheet to find as many set point pf values as applicable.

Leave the alligator clip on the probe lead wire. The capacitor substitution box will be used to inject the calculated values from the worksheet.

Calculated Probe Setup

Inject the picofarad equivalent of maximum level from line 11 of the worksheet. Watch the probe loading LED:

- 1 LED is on — close DIP detector 1 and go to step 2.
LED is off — go to step 3.
- 2 LED is on — close DIP detectors 1 & 2 and go to step 3.
LED is off — go to step 3.
- 3 Turn the span pot CW until the probe loading LED lights, and then CCW to the point where the LED goes off.

Slowly cycle the LED on and off as required to find the precise threshold at which the LED goes off.

- Turn all set point adjust pots fully CCW (25 turns CCW).
- Turn all on and off delay pots fully CCW (one turn pots).
- Set all fail safe detectors to LO position.

Continue with Calculated set point setup on the page which matches the first three digits of the model number.

- 661.....p. 14
- 662.....p. 16
- 663.....p. 18
- 664.....p. 20
- 665.....p. 22
- 666.....p. 24
- 667.....p. 26
- 668.....p. 28

<p>Solve for pf/ft.</p> <table style="width: 100%; border-collapse: collapse;"> <tr><td>Level A</td><td>10'</td><td>2200pf</td></tr> <tr><td>-Level B</td><td>-8'</td><td>-1900pf</td></tr> <tr><td>pf /ft.</td><td>2'</td><td>= 300pf</td></tr> </table> <p>Solve for pf/1 ft.</p> <table style="width: 100%; border-collapse: collapse;"> <tr><td>pf</td><td>300</td><td>=150pf/ft.</td></tr> <tr><td>ft.</td><td>2</td><td></td></tr> </table>	Level A	10'	2200pf	-Level B	-8'	-1900pf	pf /ft.	2'	= 300pf	pf	300	=150pf/ft.	ft.	2		
Level A	10'	2200pf														
-Level B	-8'	-1900pf														
pf /ft.	2'	= 300pf														
pf	300	=150pf/ft.														
ft.	2															

<p>Solve for C in ft.</p> <table style="width: 100%; border-collapse: collapse;"> <tr><td>Max Level</td><td>30ft.</td></tr> <tr><td>-Level A</td><td>-10ft.</td></tr> <tr><td>C</td><td>20ft.</td></tr> </table> <p>Convert C to pf</p> <table style="width: 100%; border-collapse: collapse;"> <tr><td>C</td><td>20ft.</td></tr> <tr><td>x pf/ft.</td><td>x150pf</td></tr> <tr><td>C in pf</td><td>3000pf</td></tr> </table>	Max Level	30ft.	-Level A	-10ft.	C	20ft.	C	20ft.	x pf/ft.	x150pf	C in pf	3000pf	
Max Level	30ft.												
-Level A	-10ft.												
C	20ft.												
C	20ft.												
x pf/ft.	x150pf												
C in pf	3000pf												

<p>Solve for Max Level in pf</p> <table style="width: 100%; border-collapse: collapse;"> <tr><td>C</td><td>20' = 3000pf</td></tr> <tr><td>+Level A</td><td>+ 10' = 2200pf</td></tr> <tr><td>Max Level</td><td>30' = 5200pf</td></tr> </table>	C	20' = 3000pf	+Level A	+ 10' = 2200pf	Max Level	30' = 5200pf	
C	20' = 3000pf						
+Level A	+ 10' = 2200pf						
Max Level	30' = 5200pf						

<p>Solve for H in pf</p> <table style="width: 100%; border-collapse: collapse;"> <tr><td>Max Level</td><td>30ft.</td></tr> <tr><td>x pf/ft.</td><td>x 150pf</td></tr> <tr><td>H</td><td>4500pf</td></tr> </table> <p>Solve for pf @ Zero ft.</p> <table style="width: 100%; border-collapse: collapse;"> <tr><td>Max Level (pf)</td><td>5200pf</td></tr> <tr><td>-H</td><td>-4500pf</td></tr> <tr><td>pf @ Zero ft.</td><td>700pf</td></tr> </table>	Max Level	30ft.	x pf/ft.	x 150pf	H	4500pf	Max Level (pf)	5200pf	-H	-4500pf	pf @ Zero ft.	700pf	
Max Level	30ft.												
x pf/ft.	x 150pf												
H	4500pf												
Max Level (pf)	5200pf												
-H	-4500pf												
pf @ Zero ft.	700pf												

<p>Convert Set point to pf</p> <table style="width: 100%; border-collapse: collapse;"> <tr><td>Set point</td><td>25ft.</td></tr> <tr><td>x pf/ft.</td><td>x 150pf</td></tr> <tr><td>L</td><td>3750pf</td></tr> </table> <p>Add zero value to L</p> <table style="width: 100%; border-collapse: collapse;"> <tr><td>L</td><td>3750pf</td></tr> <tr><td>+ Zero ft.</td><td>+ 700pf</td></tr> <tr><td>Set point</td><td>4450pf</td></tr> </table>	Set point	25ft.	x pf/ft.	x 150pf	L	3750pf	L	3750pf	+ Zero ft.	+ 700pf	Set point	4450pf	
Set point	25ft.												
x pf/ft.	x 150pf												
L	3750pf												
L	3750pf												
+ Zero ft.	+ 700pf												
Set point	4450pf												

Calculated Setup

Worksheet Sample

1	Vessel Level A	10 ft.
2	Vessel Level B	8 ft.
3	Line 1 - Line 2	10 - 8 = 2 ft.
4	Capacitance @ Level A	2200 pf
5	Capacitance @ Level B	1900 pf
6	Line 4 - Line 5	2200 - 1900 = 300 pf
7	Line 6 ÷ Line 3	300 ÷ 2 = 150 pf/ft.
8	Maximum Level30 ft.
9	Line 8 - Line 130 - 10 = 20 ft.
10	Line 9 x Line 7	20 - 150 = 3000 pf
11	Line 10 + Line 7	20 x 150 = 3000 pf
12	Line 8 x Line 7	30 x 150 = 4500 pf
13	Line 11 - Line 12	5200 - 4500 = 700 pf
14	For 661-664, 666, 668 enter set point 125 ft.
	For 665, 667 enter upper limit of adjustable differential		
15	(Line 14 x Line 7) + Line 13	(25 x 150) + 700 = 4450 pf
16	For 662-664 enter set point 220 ft.
	For 666, 668 enter upper limit of adjustable differential		
	For 665, 667 enter lower limit of adjustable differential		
17	(Line 16 x Line 7) + Line 13	(20 x 150) + 700 = 3700 pf
18	For 663, 664 enter set point 312 ft.
	For 666, 668 enter lower limit of adjustable differential		
	For 667 enter set point 4		
19	(Line 18 x Line 7) + Line 13	(12 x 150) + 700 = 2500 pf
20	For 664, 668 enter set point 4	7 ft.
21	(Line 20 x 7) + Line 13	(7 x 150) + 700 = 1750 pf

1	Vessel Level A	_____	
2	Vessel Level B	_____	
3	Line 1 - Line 2	_____ - _____ = _____	
4	Capacitance @ Level A	_____	pf
5	Capacitance @ Level B	_____	pf
6	Line 4 - Line 5	_____ - _____ = _____	pf
7	Line 6 ÷ Line 3	_____ ÷ _____ = _____	pf
8	Maximum Level	_____	
9	Line 8 - Line 1	_____ - _____ = _____	
10	Line 9 x Line 7	_____ x _____ = _____	pf
11	Line 10 + Line 7	_____ + _____ = _____	pf
12	Line 8 x Line 7	_____ x _____ = _____	pf
13	Line 11 - Line 12	_____ - _____ = _____	pf
14	For 661-664, 666, 668 enter set point 1		
	For 665, 667 enter upper limit of adjustable differential	_____	
15	(Line 14 x Line 7) + Line 13	(_____ x _____) + _____ = _____	pf
16	For 662-664 enter set point 2		
	For 666, 668 enter upper limit of adjustable differential		
	For 665, 667 enter lower limit of adjustable differential	_____	
17	(Line 16 x Line 7) + Line 13	(_____ x _____) + _____ = _____	pf
18	For 663, 664 enter set point 3		
	For 666, 668 enter lower limit of adjustable differential		
	For 667 enter set point 4	_____	
19	(Line 18 x Line 7) + Line 13	(_____ x _____) + _____ = 2500	pf
20	For 664, 668 enter set point 4		
21	(Line 20 x 7) + Line 13	(_____ x _____) + _____ = _____	pf

Model 661 Set Point Setup and Output Wiring

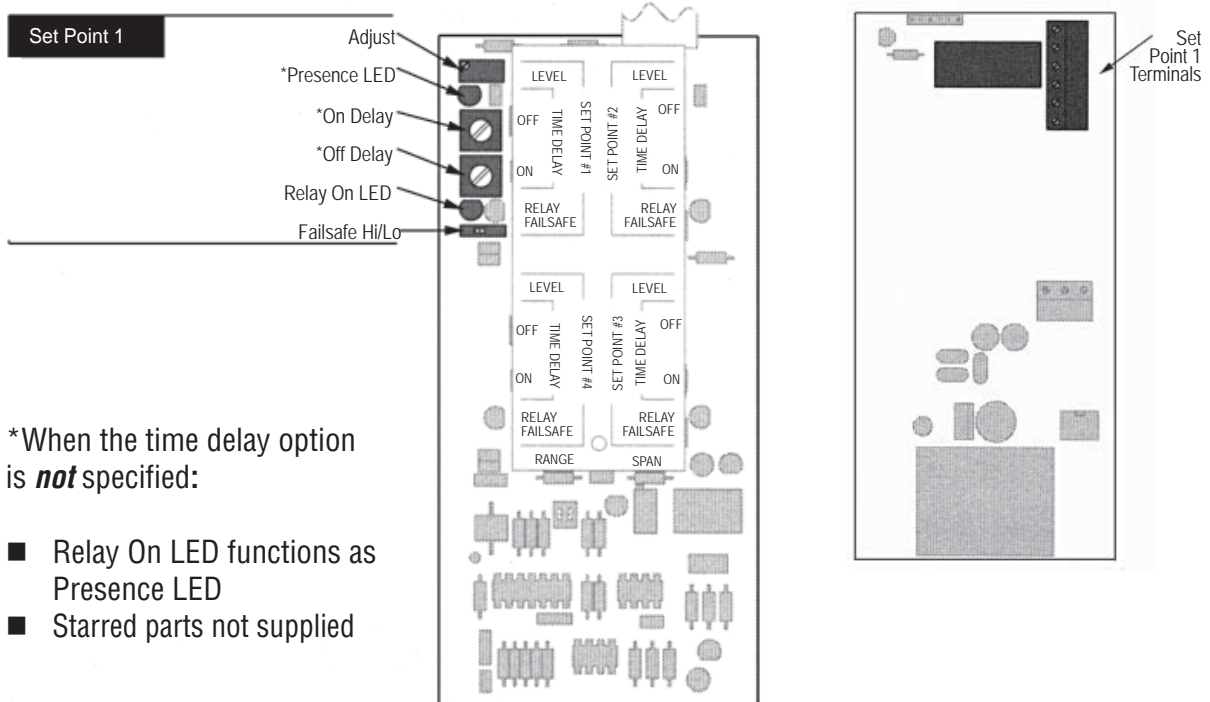

Actual Level set point setup

Continued from page 8.

Process level must be steady at set point 1 level. Turn set point 1 adjust pot CW until its Presence LED lights and then CCW to the point where the LED goes off.

Slowly cycle the Presence LED on and off as required to find the precise threshold at which the LED goes off. Continue with output wiring from the right side of this page.

Calculated set point setup

Continued from page 9.

The pf value from worksheet line 11 should still be injected. Turn set point 1 adjust pot CW until its Presence LED lights and then CCW to the point where the LED goes off.

Slowly cycle the LED on and off as required to find the precise threshold at which the LED goes off.









Disconnect the probe lead and the probe ground lead from the capacitor substitution box terminals. Connect the probe lead and the probe ground lead to the probe. Continue with output wiring from the bottom of this page.

Output Relay Wiring

Before connecting the output relay to external devices, determine which failsafe mode is best suited for the sensing level. Refer to the continuity chart to the right when connecting to the relay terminal strip.

LO mode: When the set point is satisfied, the relay turns on. When process level falls below the set point, the relay turns off and remains off until the set point is once again satisfied.

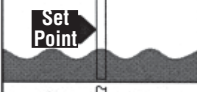
HI mode: When the set point is satisfied, the relay turns off. When process level falls below the set point, the relay turns on and remains on until set point is once again satisfied.

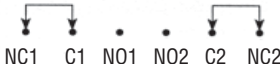
Detector Position	Set Point Status	Relay Coil	Relay Continuity
Failsafe  LO/Hi		OFF	
		ON	
Failsafe  LO/Hi		ON	
		OFF	

Time Delay Adjustments

Set point 1 may be equipped with time delay adjustments. Both on delay and off delay are one turn pots.

On Delay: Length of time that set point must be satisfied before the output relay reacts.

Off Delay: Length of time that process must be below set point before the output relay reacts.

Adjustment pot fully CCW = 0 second delay

Adjustment pot fully CW = 30 second delay (approximate)

Model 662 Set Point Setup and Output Wiring

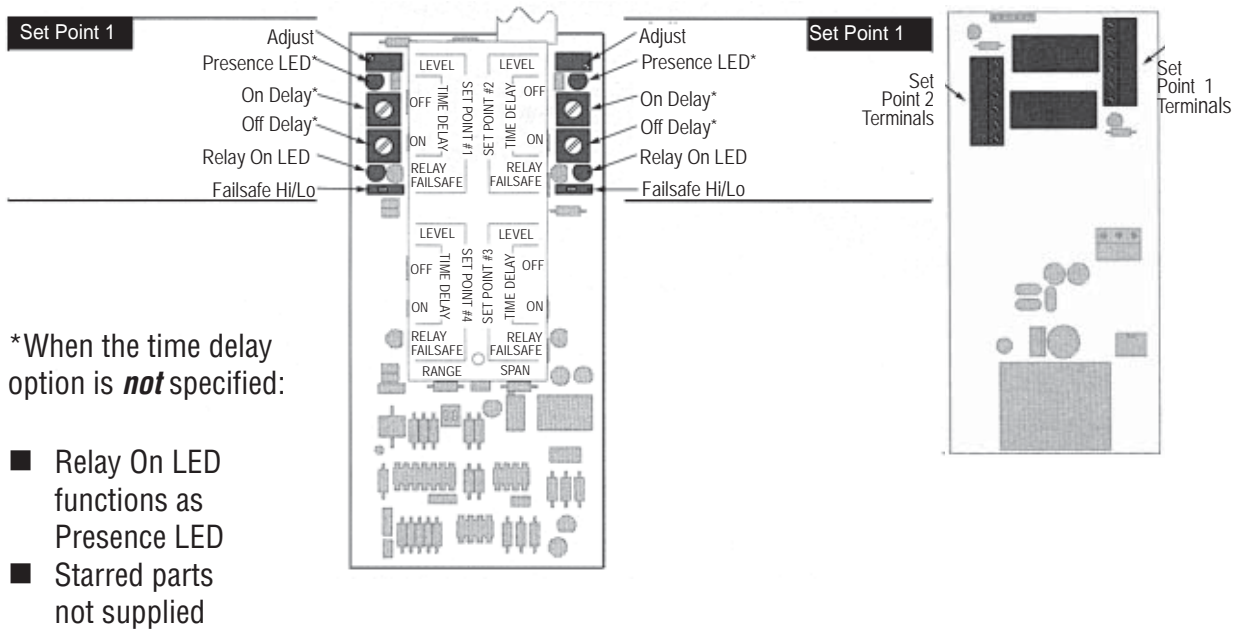

Actual Level set point setup

Continued from page 8. Process level must be steady at set point 1 level. Turn set point 1 adjust pot CW until its Presence LED lights and then CCW to the point where the LED goes off. Slowly cycle the Presence LED on and off as required to find the precise threshold at which the LED goes off.

- Lower process level to set point 2 level. Use the set point 2 adjust pot to find the threshold of its Presence LED. Continue with output wiring from the bottom of this page.

Calculated set point setup

Continued from page 9. The pf value from worksheet line 11 should still be injected. Turn set point 1 adjust pot CW until its Presence LED lights and then CCW to the point where the LED goes off. Slowly cycle the LED on and off as required to find the precise threshold at which the LED goes off.

- Inject the pf value from line 15 of the worksheet. Use the set point 2 adjust pot to find the threshold of its Presence LED. Disconnect the probe lead and the probe ground lead from the capacitor substitution box terminals.







Connect the probe lead and the probe ground lead to the probe. Continue with output wiring from the right side of this page.

Output Relay Wiring

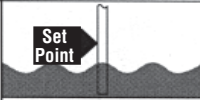
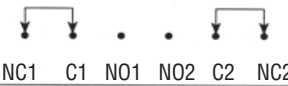
Before connecting output relays to external devices, determine which failsafe mode is best suited for each sensing level. Refer to the continuity chart below when connecting to relay terminal strips.

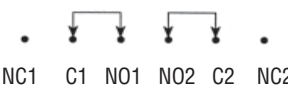
LO mode: When the set point is satisfied, the relay turns on. When process level falls below the set point, the relay turns off and remains off until the set point is once again satisfied.

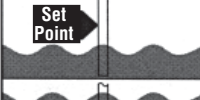
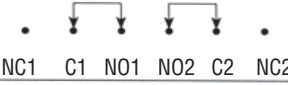
HI mode: When the set point is satisfied, the relay turns off. When process level falls below the set point, the relay turns on and remains on until set point is once again satisfied.

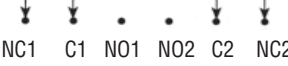
Detector Position	Set Point Status	Relay Coil	Relay Continuity
Failsafe  LO/Hi		OFF	
		ON	
Failsafe  LO/Hi		ON	
		OFF	

Time Delay Adjustments

Set points 1 and 2 may be equipped with time delay adjustments. Both on delay and off delay are one turn pots.

On Delay: Length of time that set point must be satisfied before the output relay reacts.

Off Delay: Length of time that process must be below set point before the output relay reacts.

Adjustment pot fully CCW = 0 second delay

Adjustment pot fully CW = 30 second delay (approximate)

Model 663 Set Point Setup and Output Wiring

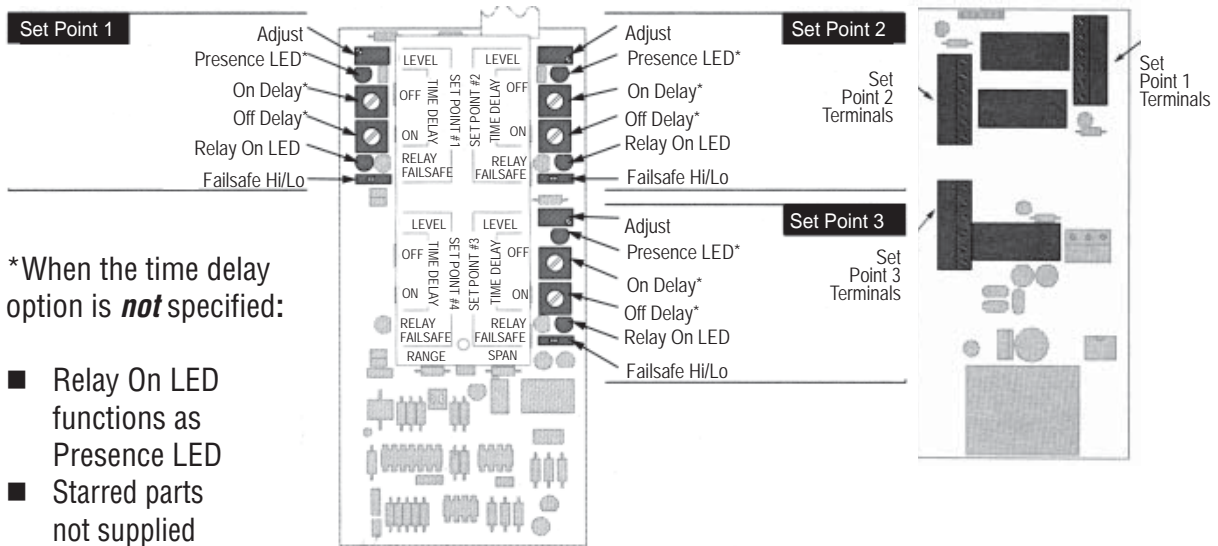

Actual Level set point setup Continued from page 8.

Process level must be steady at set point 1 level. Turn set point 1 adjust pot CW until its Presence LED lights and then CCW to the point where the LED goes off. Slowly cycle the Presence LED on and off as required to find the precise threshold at which the LED goes off.

- Lower process level to set point 2 level. Use the set point 2 adjust pot to find the threshold of its Presence LED.
- Lower process level to set point 3 level. Use set point 3 adjust pot to find the threshold of its Presence LED. Continue with output wiring from the right side of this page.

Calculated set point setup Continued from page 9.

The pf value from worksheet line 11 should still be injected. Turn set point 1 adjust pot CW until its Presence LED lights and then CCW to the point where the LED goes off. Slowly cycle the LED on and off as required to find the precise threshold at which the LED goes off.

- Inject the pf value from line 15 of the worksheet. Use the set point 2 adjust pot to find the threshold of its Presence LED.
- Inject the pf value from line 17 of the worksheet. Use the set point 3 adjust pot to find the threshold of its Presence LED.

Disconnect the probe lead and the probe ground lead from the capacitor substitution box terminals. Connect the probe lead and the probe ground lead to the probe.







Continue with output wiring from the right side of this page.

Output Relay Wiring

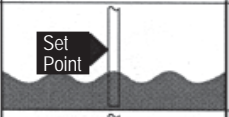
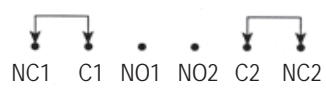
Before connecting output relays to external devices, determine which failsafe mode is best suited for each sensing level. Refer to the continuity chart below when connecting to relay terminal strips.

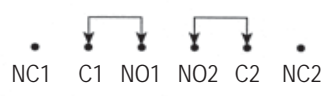
LO mode: When the set point is satisfied, the relay turns on. When process level falls below the set point, the relay turns off and remains off until the set point is once again satisfied.

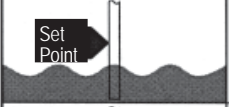
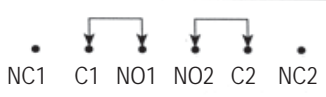
HI mode: When the set point is satisfied, the relay turns off. When process level falls below the set point, the relay turns on and remains on until set point is once again satisfied.

Detector Position	Set Point Status	Relay Coil	Relay Continuity
Failsafe  LO/HI		OFF	
		ON	
Failsafe  LO/HI		ON	
		OFF	

Time Delay Adjustments

Set points 1, 2 and 3 may be equipped with time delay adjustments. Both on delay and off delay are one turn pots.

On Delay: Length of time that set point must be satisfied before the output relay reacts.

Off Delay: Length of time that process must be below set point before the output relay reacts.

Adjustment pot fully CCW = 0-second delay

Adjustment pot fully CW = 30-second delay (approximate)

Model 664 Set Point Setup and Output Wiring

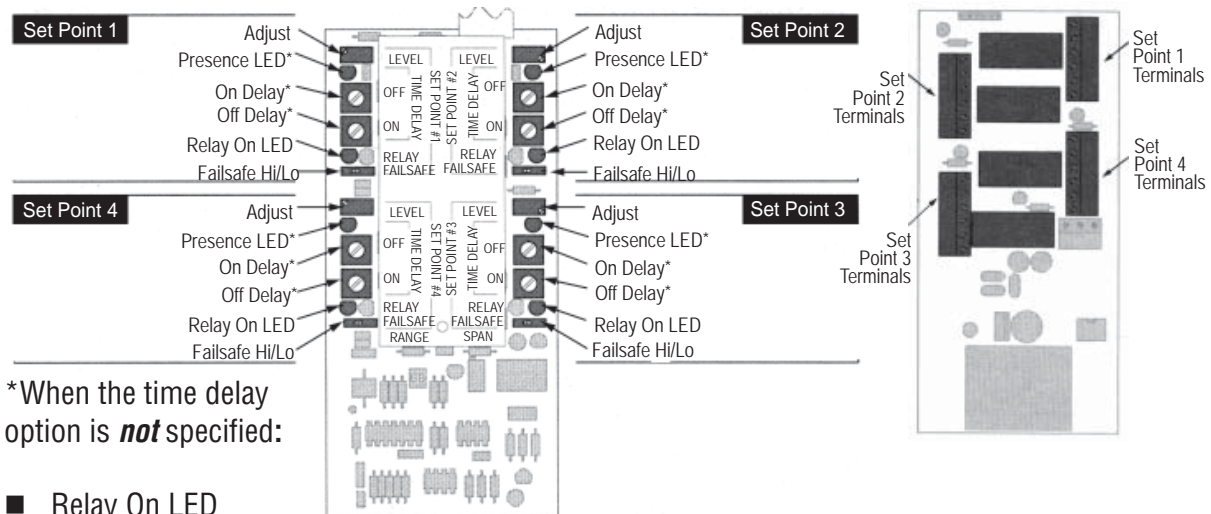

Actual Level set point setup

Continued from page 8.

Process level must be steady at set point 1 level. Turn set point 1 adjust pot CW until its Presence LED lights and then CCW to the point where the LED goes off. Slowly cycle the Presence LED on and off as required to find the precise threshold at which the LED goes off.

- Lower process level to set point 2 level. Use the set point 2 adjust pot to find the threshold of its Presence LED.
- Lower process level to set point 3 level. Use set point 3 adjust pot to find the threshold of its Presence LED.
- Lower process level to set point 4 level. Use the set point 4 adjust pot to find the threshold of its Presence LED. Continue with output wiring on the next page.

Calculated set point setup

Continued from page 9.

The pf value from worksheet line 11 should still be injected. Turn set point 1 adjust pot CW until its Presence LED lights and then CCW to the point where the LED goes off. Slowly cycle the LED on and off as required to find the precise threshold at which the LED goes off.

- Inject the pf value from line 15 of the worksheet. Use the upper limit (pump up) adjust pot to find the threshold of its Presence LED.
- Inject the pf value from line 17 of the worksheet. Use the lower limit (pump down) adjust pot to find the threshold of its Presence LED.
- Inject the pf value from line 19 of the worksheet. Use the set point 4 adjust pot to find the threshold of its Presence LED.







Disconnect the probe lead and the probe ground lead from the capacitor substitution box terminals. Connect the probe lead and the probe ground lead to the probe. Continue with output wiring on the next page.

Output Relay Wiring

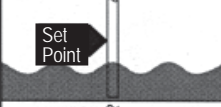
Before connecting output relays to external devices, determine which failsafe mode is best suited for each sensing level. Refer to the continuity chart below when connecting to relay terminal strips.

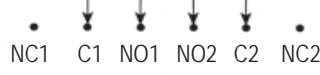
LO mode: When the set point is satisfied, the relay turns on. When process level falls below the set point, the relay turns off and remains off until the set point is once again satisfied.

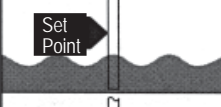
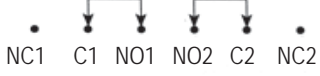
HI mode: When the set point is satisfied, the relay turns off. When process level falls below the set point, the relay turns on and remains on until set point is once again satisfied.

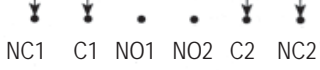
Detector Position	Set Point Status	Relay Coil	Relay Continuity
Failsafe  LO/HI		OFF	
		ON	
Failsafe  LO/HI		ON	
		OFF	

Time Delay Adjustments

Set points 1, 2, 3 and 4 may be equipped with time delay adjustments. Both on delay and off delay are one turn pots.

On Delay: Length of time that set point must be satisfied before the output relay reacts.

Off Delay: Length of time that process must be below set point before the output relay reacts.

Adjustment pot fully CCW = 0-second delay

Adjustment pot fully CW = 30-second delay (approximate)

Model 665 Set Point Setup and Output Wiring

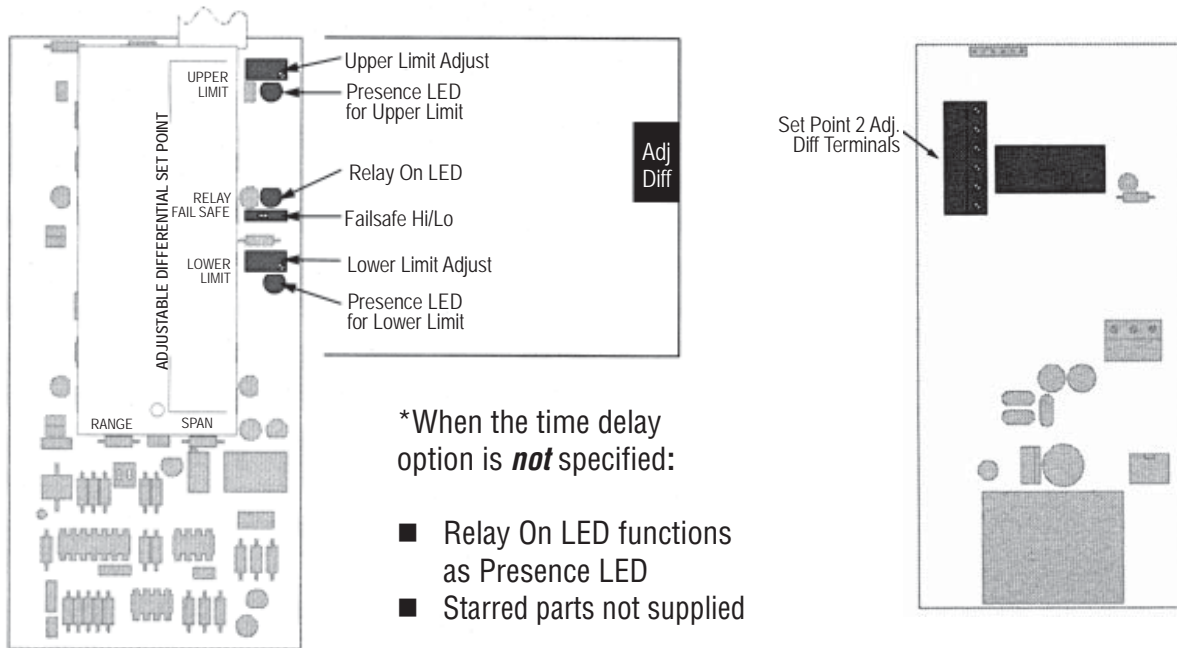

Actual Level set point setup

Continued from page 8.

Process level must be steady at upper limit of adjustable dead band.

Turn upper limit (pump up) adjust pot CW until its Presence LED lights and then CCW to the point where the LED goes off. Slowly cycle the Presence LED on and off as required to find the precise threshold at which the LED goes off.

- Lower process level to lower limit. Use the lower limit (pump down) adjust pot to find the threshold of its Presence LED. Continue with output wiring on the next page.

Calculated set point setup

Continued from page 9.

The pf value from worksheet line 11 should still be injected.

Turn the upper limit (pump up) adjust pot CW until its Presence LED lights and then CCW to the point where the LED goes off.

Slowly cycle the LED on and off as required to find the precise threshold at which the LED goes off.

- Inject the pf value from line 15 of the worksheet. Use the lower limit (pump down) adjust pot to find the threshold of its Presence LED. Disconnect the probe lead and the probe ground lead to the probe. Continue with output wiring on the next page.







Output Relay Wiring

Before connecting the output relay to external devices, determine which failsafe mode is best suited for the adjustable differential set point. Refer to the continuity chart below when connecting to the adjustable differential relay terminal strips.

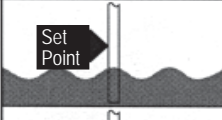
For the adjustable differential set point:

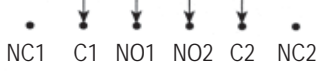
LO mode: When the upper limit is satisfied, the relay turns on. When process level falls below the lower limit, the relay turns off and remains off until the set point is once again satisfied.

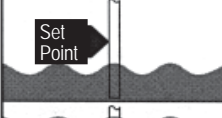
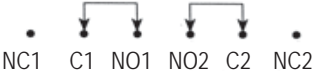
HI mode: When the upper limit is satisfied, the relay turns off. When process level falls below the lower limit, the relay turns on and remains on until the upper limit is once again satisfied.

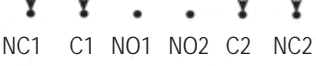
Detector Position	Set Point Status	Relay Coil	Relay Continuity
Failsafe  LO/Hi		OFF	
LO/Hi		ON	
Failsafe  LO/Hi		ON	
LO/Hi		OFF	

Model 666 Set Point Setup and Output Wiring

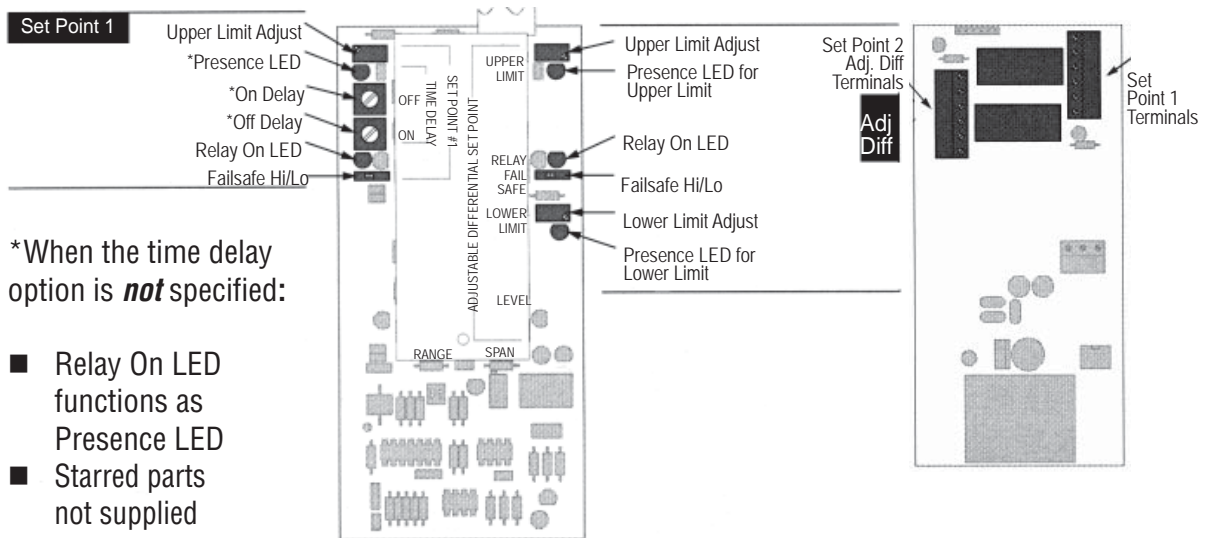

Actual Level set point setup

Continued from page 8.

Process level must be steady at set point 1 level. Turn set point 1 adjust pot CW until its Presence LED lights and then CCW to the point where the LED goes off. Slowly cycle the Presence LED on and off as required to find the precise threshold at which the LED goes off.

- Lower process level to upper limit. Use the upper limit (pump up) adjust pot to find the threshold of its Presence LED.
- Lower process level to lower limit. Use the lower limit (pump down) adjust pot to find the threshold of its Presence LED.

Calculated set point setup

Continued from page 9.

The pf value from worksheet line 11 should still be injected. Turn set point 1 adjust pot CW until its Presence LED lights and then CCW to the point where the LED goes off. Slowly cycle the LED on and off as required to find the precise threshold at which the LED goes off.

- Inject the pf value from line 15 of the worksheet. Use the upper limit (pump up) adjust pot to find the threshold of its Presence LED.
- Inject the pf value from line 17 of the worksheet. Use the lower limit (pump down) adjust pot to find the threshold of its Presence LED.

Disconnect the probe lead and the probe ground lead from the capacitor substitution box terminals. Connect the probe lead and the probe ground lead to the probe. Continue with output wiring from the right side of this page.

Output Relay Wiring

Before connecting output relays to external devices, determine which failsafe mode is best suited for each sensing level. Refer to the continuity chart below when connecting to relay terminal strips.

For set point 1:





LO mode: When the set point is satisfied, the relay turns on. When process level falls below the set point, the relay turns off and remains off until the set point is once again satisfied.

HI mode: When the set point is satisfied, the relay turns off. When process level falls below the set point, the relay turns on and remains on until set point is once again satisfied.

For the adjustable differential set point:

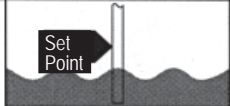
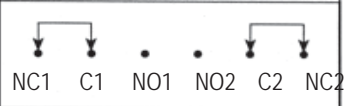
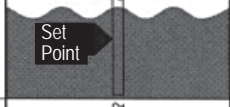
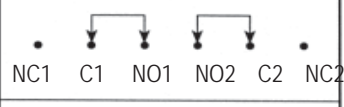
LO mode: When the upper limit is satisfied, the relay turns on. When process level falls below the lower limit, the relay turns off and remains off until the set point is once again satisfied.

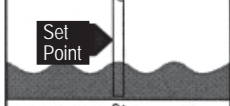
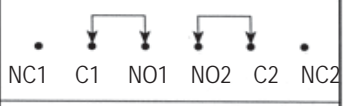
HI mode: When the upper limit is satisfied, the relay turns off. When process level falls below the lower limit, the relay turns on and remains on until the upper limit is once again satisfied.

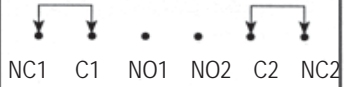
Detector Position	Set Point Status	Relay Coil	Relay Continuity
Failsafe  LO/HI		OFF	
LO/HI		ON	
Failsafe  LO/HI		ON	
LO/HI		OFF	

Time Delay Adjustments

Set point 1 may be equipped with time delay adjustments.

Both on delay and off delay are one turn pots.

On Delay: Length of time that set point must be satisfied before the output relay reacts.

Off Delay: Length of time that process must be below set point before the output relay reacts.

Adjustment pot fully CCW = 0-second delay

Adjustment pot fully CW = 30-second delay (approximate)

Model 667 Set Point Setup and Output Wiring

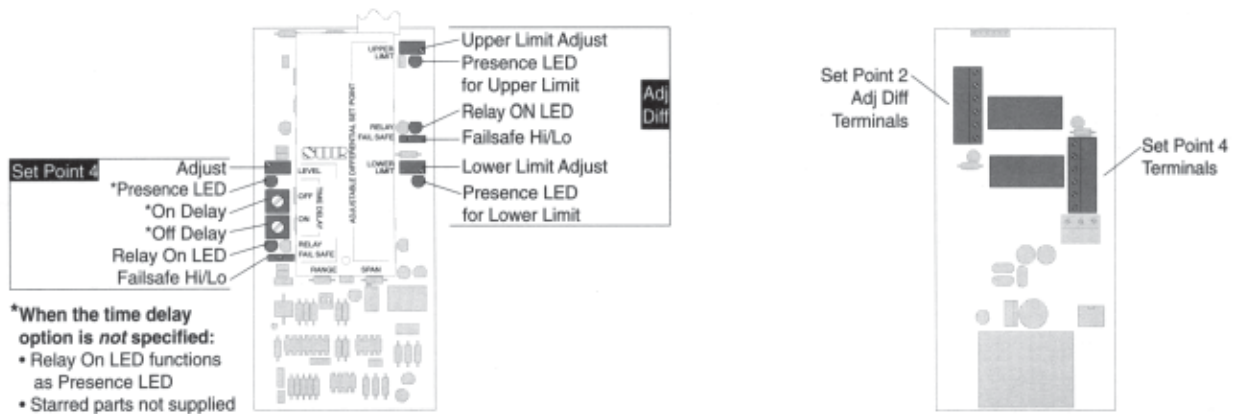

Actual Level set point setup

Continued from page 8.

Process level must be steady at the upper limit of the adjustable differential set point. Turn upper limit (pump up) adjust pot CW until its Presence LED lights and then CCW to the point where the LED goes off. Slowly cycle the Presence LED on and off as required to find the precise threshold at which the LED goes off.

- Lower process level to lower limit of the adjustable differential set point. Use the lower limit (pump down) adjust pot to find the threshold of its Presence LED.
- Lower process level to set point 4 level. Use the set point 4 adjust pot to find the threshold of its Presence LED.

Continue with output wiring from the bottom of this page.

Calculated set point setup

Continued from page 9.

The pf value from worksheet line 11 should still be injected. Turn the upper limit (pump up) adjust pot CW until its Presence LED lights and then CCW to the point where the LED goes off. Slowly cycle the LED on and off as required to find the precise threshold at which the LED goes off.

- Inject the pf value from line 15 of the worksheet. Use the lower limit (pump down) adjust pot to find the threshold of its Presence LED.
- Inject the pf value from line 17 of the worksheet. Use the set point 4 adjust pot to find the threshold of its Presence LED.

Disconnect the probe lead and the probe ground lead from the capacitor substitution box terminals. Connect the probe lead and the probe ground lead to the probe. Continue with output wiring from the right side of this page.

Output Relay Wiring

Before connecting output relays to external devices, determine which failsafe mode is best suited for each sensing level. Refer to the continuity chart below when connecting to relay terminal strips.

For set point 4:









LO mode: When the set point is satisfied, the relay turns on. When process level falls below the set point, the relay turns off and remains off until the set point is once again satisfied.

HI mode: When the set point is satisfied, the relay turns off. When process level falls below the set point, the relay turns on and remains on until set point is once again satisfied.

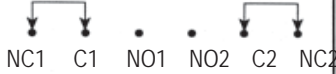
For the adjustable differential set point:

LO mode: When the upper limit is satisfied, the relay turns on. When process level falls below the lower limit, the relay turns off and remains off until the set point is once again satisfied.

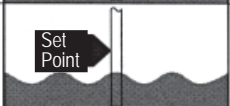
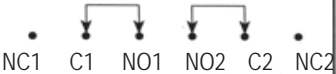
HI mode: When the upper limit is satisfied, the relay turns off. When process level falls below the lower limit, the relay turns on and remains on until the upper limit is once again satisfied.

Detector Position	Set Point Status	Relay Coil	Relay Continuity
Failsafe 		OFF	
LO/HI		ON	
Failsafe 		ON	
LO/HI		OFF	

Time Delay Adjustments

Set point 4 may be equipped with time delay adjustments. Both on delay and off delay are one turn pots.

On Delay: Length of time that set point must be satisfied before the output relay reacts.

Off Delay: Length of time that process must be below set point before the output relay reacts.

Adjustment pot fully CCW = 0-second delay

Adjustment pot fully CW = second delay (approximate)

Model 668 Set Point Setup and Output Wiring

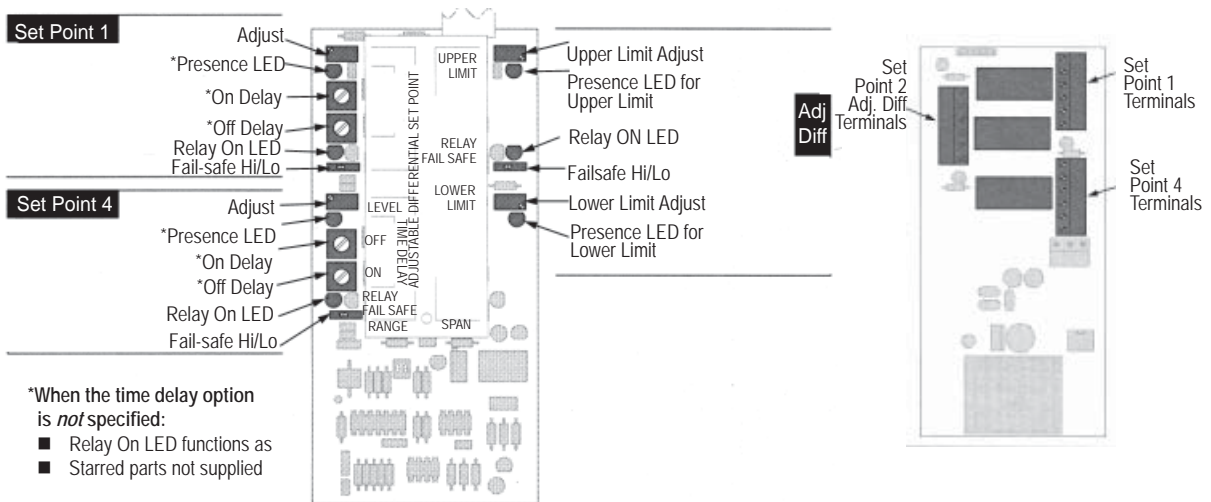

Actual Level set point setup Continued from page 8.

Process level must be steady at set point 1 level. Turn set point 1 adjust pot CW until its Presence LED lights and then CCW to the point where the LED goes off. Slowly cycle the Presence LED on and off as required to find the precise threshold at which the LED goes off.

- Lower process level to upper limit of the adjustable differential set point. Use the upper limit (pump up) adjust pot to find the threshold of its Presence LED.
- Lower process level to lower limit of the adjustable differential set point. Use the lower limit (pump down) adjust pot to find the threshold of its Presence LED.
- Lower process level to set point 4 level. Use the set point 4 adjust pot to find the threshold of its Presence LED.

Continue with output wiring from the right side of this page.

Calculated set point setup Continued from page 9.

The pf value from worksheet line 11 should still be injected. Turn set point 1 adjust pot CW until its Presence LED lights and then CCW to the point where the LED goes off. Slowly cycle the LED on and off as required to find the precise threshold at which the LED goes off.

- Inject the pf value from line 15 of the worksheet. Use the upper limit (pump up) adjust pot to find the threshold of its Presence LED.
- Inject the pf value from line 17 of the worksheet. Use the lower limit (pump down) adjust pot to find the threshold of its Presence LED.
- Inject the pf value from line 19 of the worksheet. Use the set point 4 adjust pot to find the threshold of its Presence LED.

Disconnect the probe lead and the probe ground lead from the capacitor substitution box terminals. Connect the probe lead and the probe ground lead to the probe. Continue with output wiring from the right side of this page.

Output Relay Wiring

Before connecting output relays to external devices, determine which failsafe mode is best suited for each sensing level. Refer to the continuity chart below when connecting to relay terminal strips.

For set point 1 & 4:









LO mode: When the set point is satisfied, the relay turns on. When process level falls below the set point, the relay turns off and remains off until the set point is once again satisfied.

HI mode: When the set point is satisfied, the relay turns off. When process level falls below the set point, the relay turns on and remains on until set point is once again satisfied.

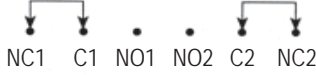
For the adjustable differential set point:

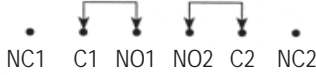
LO mode: When the upper limit is satisfied, the relay turns on. When process level falls below the lower limit, the relay turns off and remains off until the set point is once again satisfied.

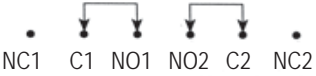
HI mode: When the upper limit is satisfied, the relay turns off. When process level falls below the lower limit, the relay turns on and remains on until the upper limit is once again satisfied.

Detector Position	Set Point Status	Relay Coil	Relay Continuity
Failsafe 		OFF	
LO/Hi		ON	
Failsafe 		ON	
LO/Hi		OFF	

Time Delay Adjustments

Set points 1 and 4 may be equipped with time delay adjustments. Both on delay and off delay are one turn pots.

On Delay: Length of time that set point must be satisfied before the output relay reacts.

Off Delay: Length of time that process must be below set point before the output relay reacts.

Adjustment pot fully CCW = 0-second delay

Adjustment pot fully CW = second delay (approximate)

SOR RF Probe Grounding Scheme

Critical Grounding Path = ●-----●

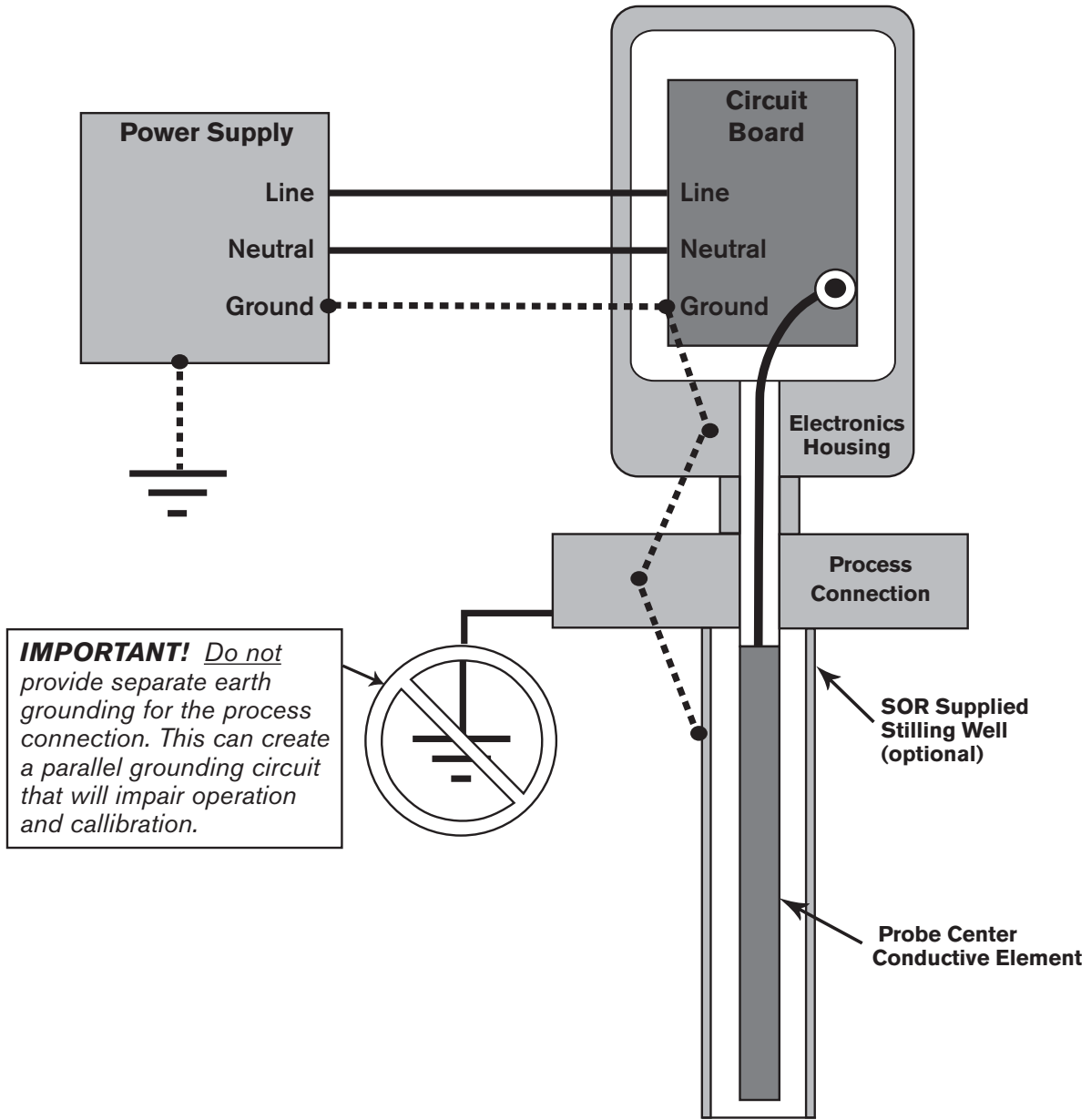

Control Drawing



14685 West 105th Street Lenexa, Kansas 66215 USA
Tel. 913-888-2630 Fax 913-888-0767

DRAWING NO. 9093-010

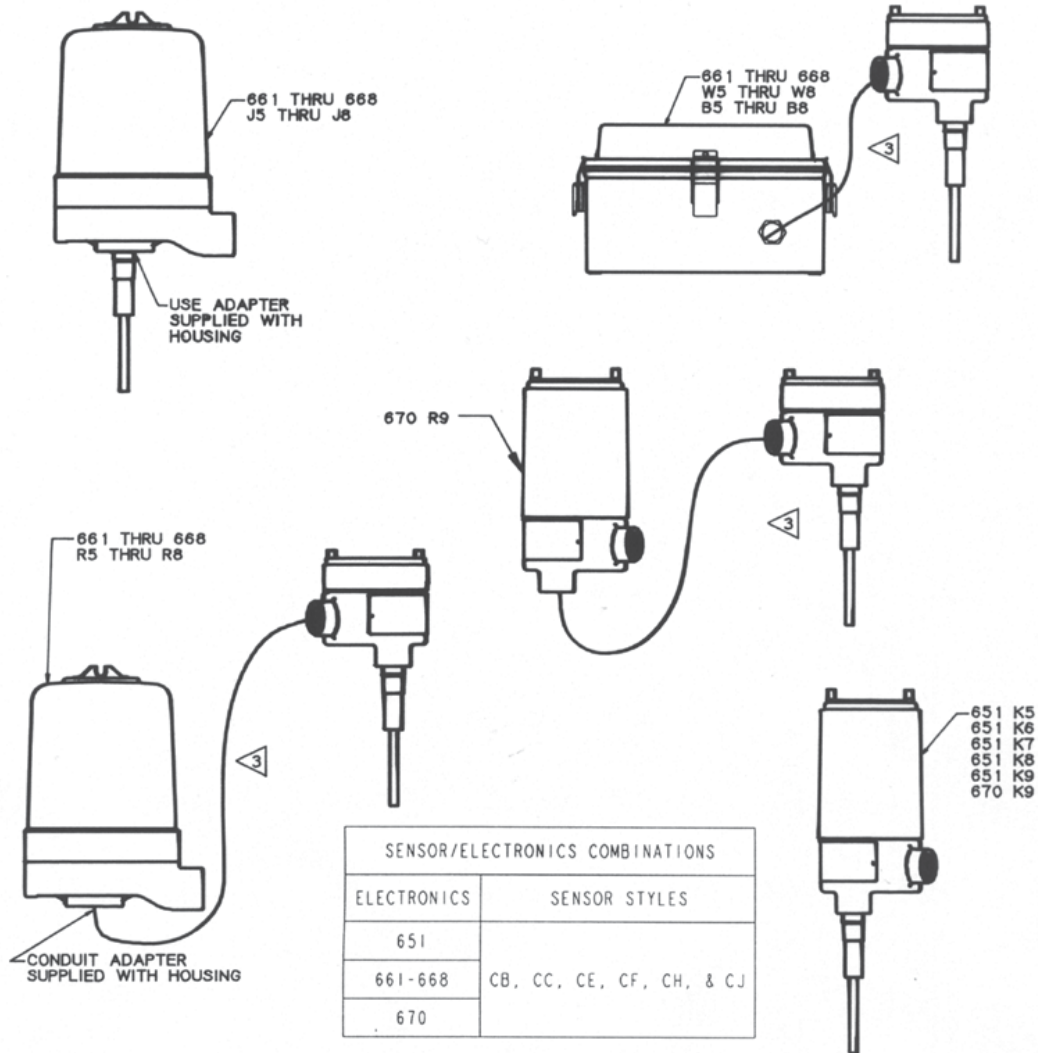

SENSOR/ELECTRONICS COMBINATIONS	
ELECTRONICS	SENSOR STYLES
651	CB, CC, CE, CF, CH, & CJ
661-668	
670	

- NOTE:
1. ONLY THOSE FMRC APPROVED SENSOR/ELECTRONICS COMBINATIONS LISTED ABOVE ARE VALID.
 2. SENSOR/ELECTRONICS COMBINATION IS CERTIFIED FOR THE LESSER HAZARDOUS LOCATION RATING OF THE SENSOR OR THE ELECTRONICS HOUSING. FOR EXAMPLE THE ASSEMBLY OF A GROUP B SENSOR WITH A GROUP C HOUSING IS CERTIFIED FOR GROUP C.
 3. WIRING SHALL BE INSTALLED IN COMPLIANCE WITH THE NATIONAL ELECTRIC CODE FOR HAZARDOUS (CLASSIFIED) LOCATIONS. SUITABLE LISTED SEAL FITTINGS SHALL BE INSTALLED WITHIN 18" OF EACH ENCLOSURE ENTRANCE.
 4. A MINIMUM OF 5 FULL THREAD ENGAGEMENT BETWEEN ALL NPT THREAD JOINTS AND BETWEEN PROBE AND HOUSING CONNECTIONS IS REQUIRED PER NEC.

THIS DRAWING NOT TO BE CHANGED WITHOUT FM APPROVAL.

1	EO-3874	WJG	4/25/96	MLS
2	EO-4281	MLS	9/16/02	AB5

TITLE INSTALLATION DRAWING FM RF EXPF PROBE/ELECTRONICS COMBINATIONS		BY WJG	DATE 6/25/96	DRAWING NO. 9093-010	REV 2
APPD JOC	DATE 7/1/96	SHEET 1 OF 1			

Control Drawing



14685 West 105th Street Lenexa, Kansas 66215 USA
Tel. 913-888-2630 Fax 913-888-0767

DRAWING NO. 9093-011

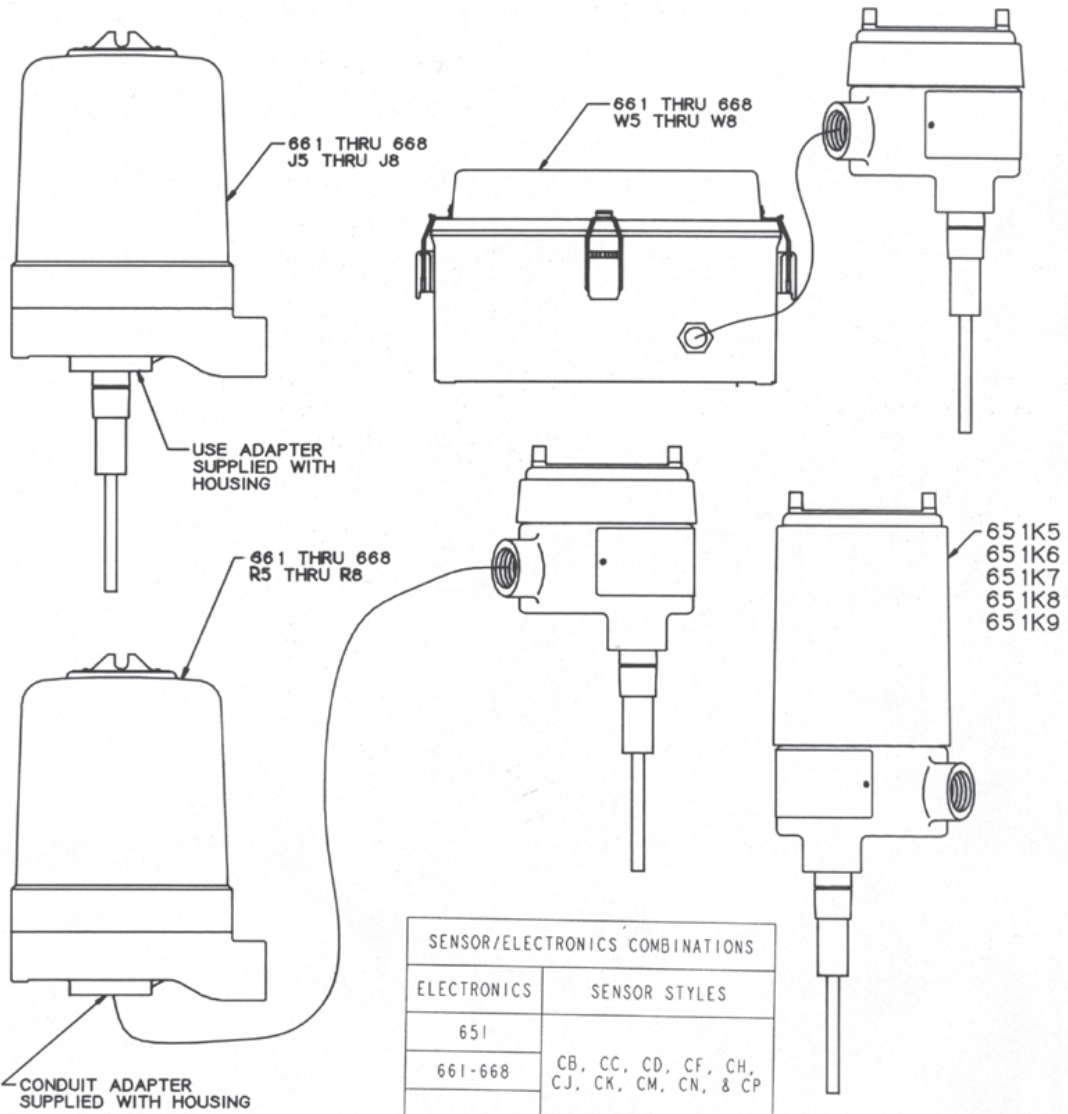

SENSOR/ELECTRONICS COMBINATIONS	
ELECTRONICS	SENSOR STYLES
651	CB, CC, CD, CF, CH, CJ, CK, CM, CN, & CP
661-668	

NOTE:

1. ONLY THOSE SENSOR/ELECTRONICS COMBINATIONS LISTED ABOVE ARE VALID.
2. SENSOR/ELECTRONICS COMBINATION IS CERTIFIED FOR THE LESSER HAZARDOUS LOCATION RATING OF THE SENSOR OR THE ELECTRONICS HOUSING. FOR EXAMPLE THE ASSEMBLY OF A GROUP B SENSOR WITH A GROUP C HOUSING IS CERTIFIED FOR GROUP C.
3. WIRING SHALL BE INSTALLED IN COMPLIANCE WITH APPLICABLE CSA EXPLOSION PROOF STANDARDS FOR HAZARDOUS LOCATIONS.

THIS DRAWING NOT TO BE CHANGED WITHOUT CSA APPROVAL.

1	EO-3812	J. Wig	9-6-96	MLS	JD
2	EO-4281	MLS	9/16/96	MLS	

TITLE INSTALLATION DRAWING CSA RF EXPF PROBE/ELECTRONICS COMBINATIONS		BY JWIG	DATE 9-6-96	DRAWING NO. 9093-011	REV 2
		APPD JCIC	DATE 9-9-96	SHEET 1	OF 1

Dimensions - W Housing Configuration

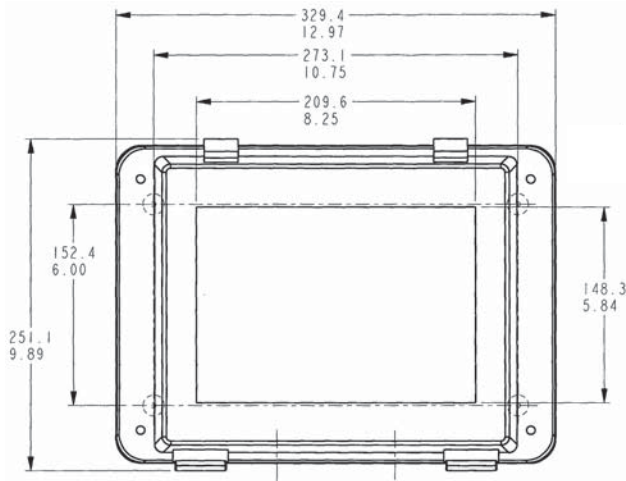

*Dimensions are for reference only.
Contact the factory for certified drawings for a particular model number.*

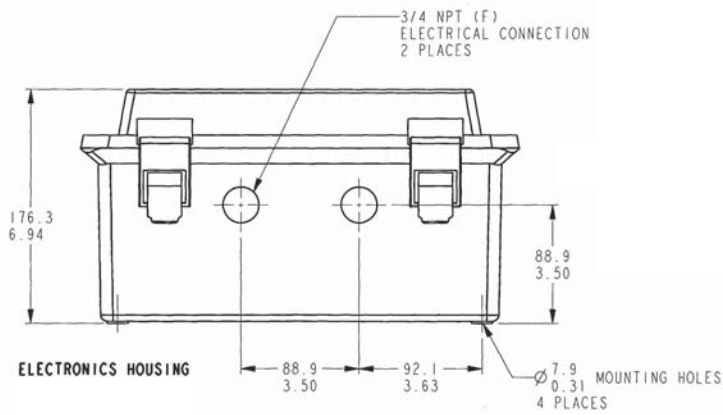

NOTES:
1. THESE DIMENSION ARE BASED UPON A 5 THREAD ENGAGEMENT.

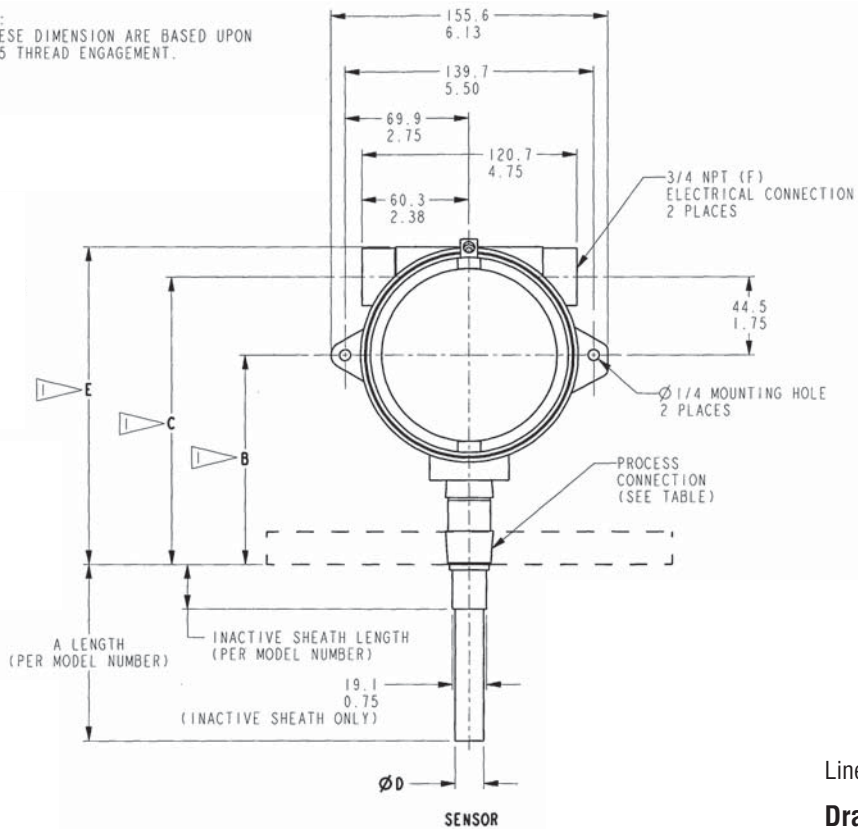

Linear = mm/inches

Drawing 0390655

Dimensions - J Housing Configuration (Explosion Proof Integral)

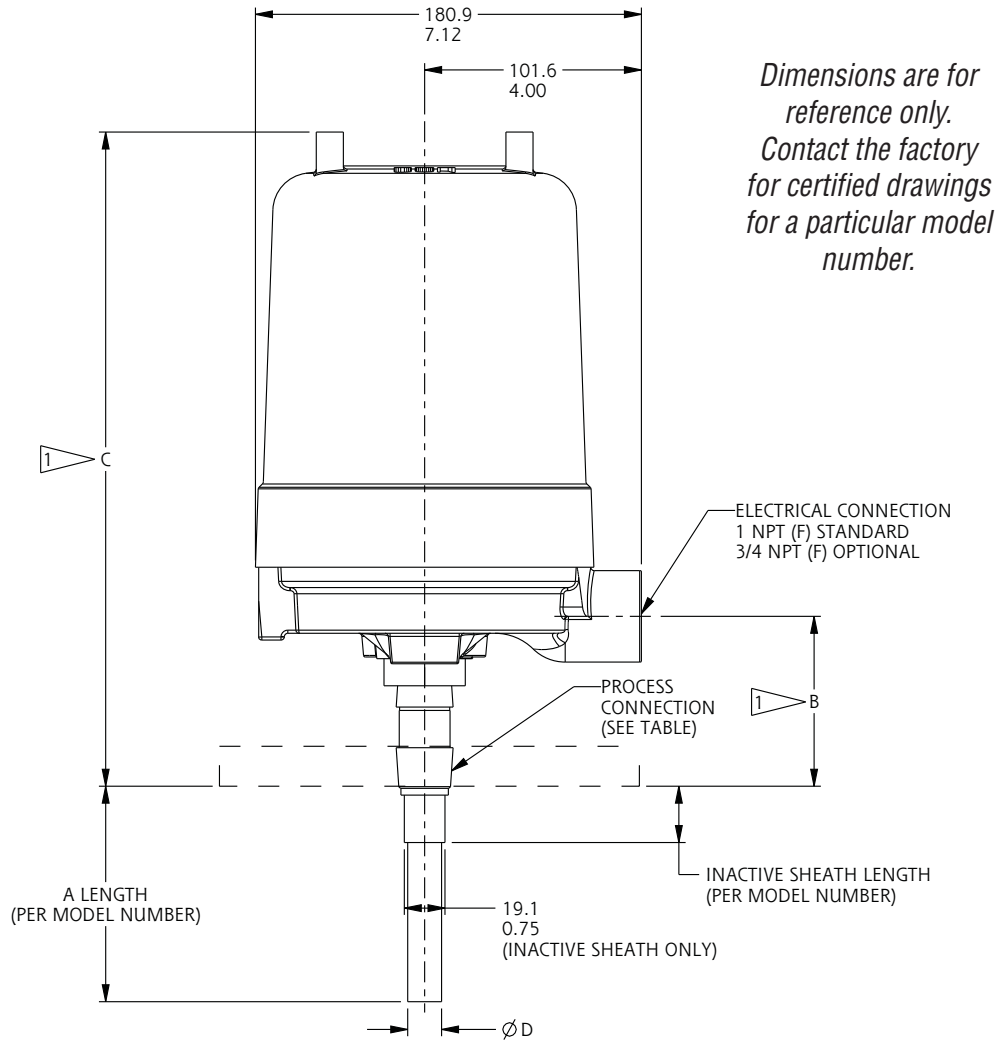

NOTES:
 1. THESE DIMENSIONS ARE BASED UPON A 5 THREAD ENGAGEMENT.

SENSOR STYLE	$\varnothing D$	DIM B		DIM C	
		CABLE PROBE	ALL OTHER PROBES	CABLE PROBE	ALL OTHER PROBES
BARE	12.7 0.50	72.3 2.85	78.6 3.10	299.3 11.78	305.6 12.03
SHEATH	15.9 0.63	84.2 3.31	81.8 3.22	311.2 12.25	308.8 12.16
BARE WITH STILLING WELL	26.7 1.05	143.0 5.63	183.9 7.24	370.1 14.57	370.1 14.57
SHEATH WITH STEALING WELL	26.7 1.05	N/A	104.5 4.11	N/A	331.5 13.05
CABLE	7.90 0.31	N/A	78.6 3.10	N/A	305.6 12.03
INACTIVE SHEATH	15.9 0.63				
SANITARY	15.9 0.63				

Linear = mm/inches

Drawing 0390656

Dimensions - R Housing Confirmation (Explosion-Proof Remote)

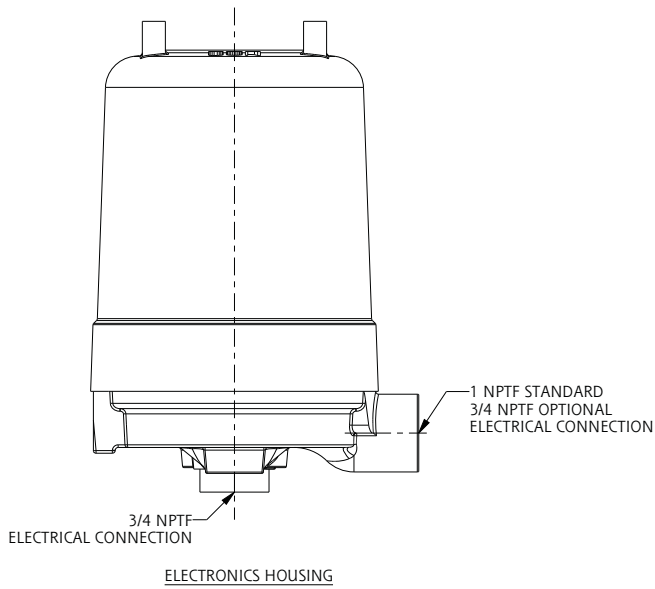

*Dimensions are for reference only.
Contact the factory for certified drawings for a particular model number.*

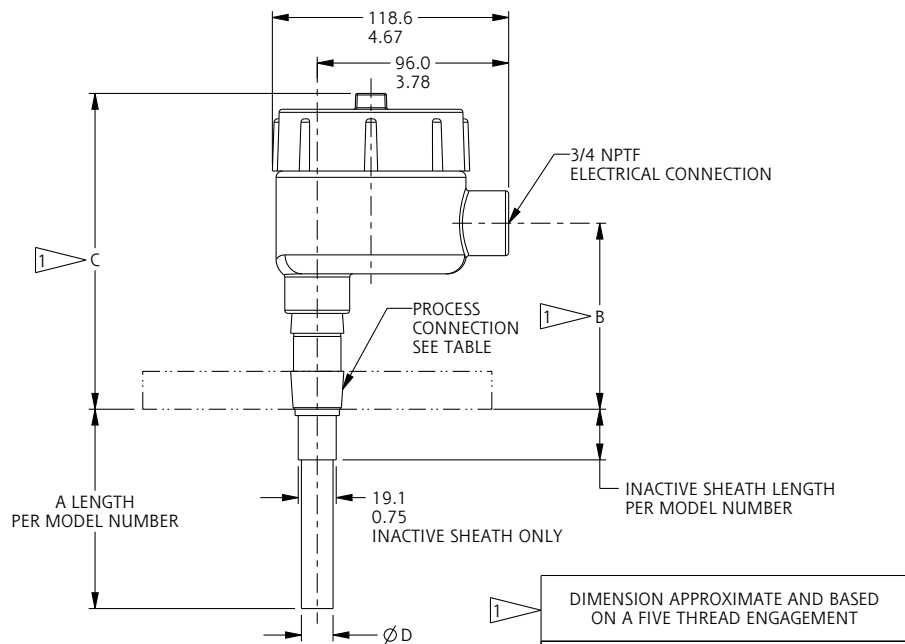

PROCESS CONNECTION	DIM B		DIM C		SENSOR STYLE	Ø D
	CABLE PROBE	ALL OTHER PROBES	CABLE PROBE	ALL OTHER PROBES		
3/4 NPT (M)	87.8 3.46	94.1 3.71	152.9 6.02	159.2 6.27	BARE	12.7 0.50
1, 1-1/2, & 2 NPT (M)	99.7 3.92	97.3 3.83	164.8 6.49	162.4 6.39	SHEATH	15.9 0.63
FLANGED	158.5 6.24	158.5 6.24	223.7 8.81	223.7 8.81	BARE WITH STILLING WELL	26.7 1.05
STILLING WELL	N/A	120.0 4.72	N/A	185.1 7.29	SHEATH WITH STILLING WELL	26.7 1.05
SANITARY	N/A	94.1 3.71	N/A	159.2 6.27	CABLE	7.90 0.31
					INACTIVE SHEATH	15.9 0.63
					SANITARY	15.9 0.63

Linear = mm/inches

Drawing 0390657

Dimensions - Other Sensors

*Dimensions are for reference only.
Contact the factory for certified drawings for a particular model number.*

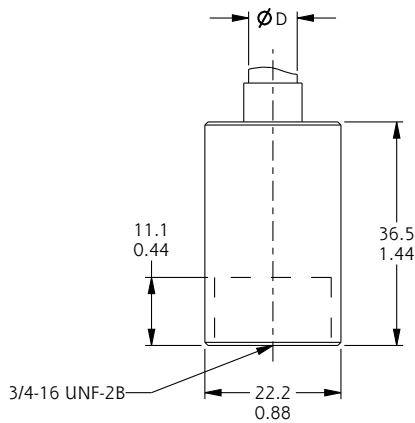
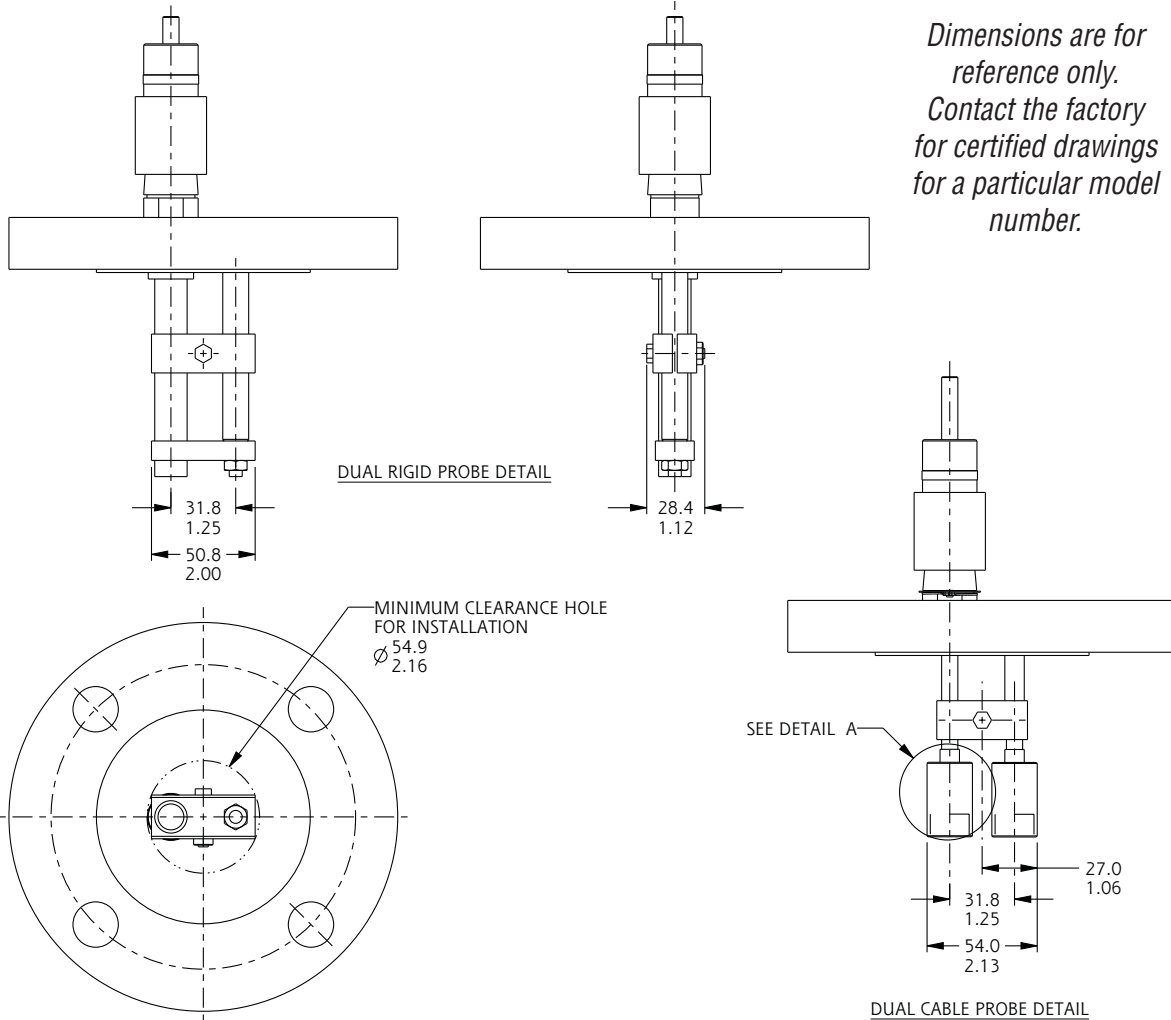

Linear = mm/inches

Drawing 0390657



Printed in USA

www.sorinc.net

14685 West 105th Street, Lenexa, KS 66215 ■ 913-888-2630 ■ 800-676-6794 USA ■ Fax 913-888-0767