



800 Series Pressure Transmitters LCD Digital Indicating Display

General Instructions

These instructions provide information for installation, electrical connection, configurations, operation, and maintenance of the LCD digital indicating display. The display consists of explosion proof die cast aluminum housing, terminal block connections for easy wiring, and a LCD digital indicating loop powered display.



The LCD digital indicating display adds an additional 8V loop drop (max).

NOTE: If you suspect that a product is defective, contact the factory or the SOR® Representative in your area for a return authorization number (RMA). This product should only be installed by trained and competent personnel.

Design and specifications are subject to change without notice.

*For latest revision, go to **SORInc.com***

Table of Contents

Installation	2
Electrical Termination	4
Electrical Conduit Connection	5
Setup and Configuration	6
Maintenance	9
Dimensions	10

Installation

Ensure that wiring conforms to all applicable local and national electrical codes and install unit(s) according to relevant nation and local safety codes.

If display was purchased with an SOR 800 Series pressure transmitter, then display will already be installed with instrumentation. If display was purchased separately by itself or the remote display option was selected, see below for installation instructions for specific 800 Series pressure transmitter.

If you received a display without a sensor installed or the remote display option was selected, follow the instructions below.

- ❶ Unscrew the display housing cover.
- ❷ To access terminal connections, rotate the display screen to line up the holes. Using a 1/8" flat screw driver, unscrew the support screws. After one screw has been removed, rotate the screen again to line up the holes on the opposite side in order to remove the second support screw.
- ❸ Cut the cable of the 800 series sensor at approximately 6 inches beyond the shrink sleeving.
- ❹ Slit the chrome PVC jacket from the cut end to the shrink sleeving.
- ❺ Cut off the jacket and foil shield.
- ❻ Thread the remaining wires through the process opening in the bottom of the display housing, fishing the wires out through the front opening of the housing.
- ❼ Apply any sealant that might be required for your application environment to the threads on the sensor.
- ❽ Thread the sensor into the display housing and tighten.
- ❾ Cut the blue and drain wires off close to the jacket (unused voltage output).
- ❿ Strip the remaining wires to approximately 1/4 inch.
- ⓫ Remove the terminal block plug from the right side of the PCB.
- ⓬ With the wire cages facing up and the screws to the right, connect the wires as follows (see diagrams below):
 - a. Top opening (loop +), should already be attached to display (mA -).
 - b. Second opening (loop -), attach black wire from sensor.
 - c. Third opening (485 A), attach brown wire from sensor. 815 only.
 - d. Fourth opening (485 B), attach white wire from sensor. 815 only.
 - e. Fifth opening (SW 1), attach orange wire from sensor. 815 and 805QS only.
 - f. Bottom opening (SW 2), attach yellow wire from sensor. 815 and 805QS only.
- ⓭ Connect the red wire from the sensor to display terminal (mA +).
- ⓮ Connect green wire from the sensor to lower right PCB attaching screw.
- ⓯ Plug this terminal block into right side of the PCB.

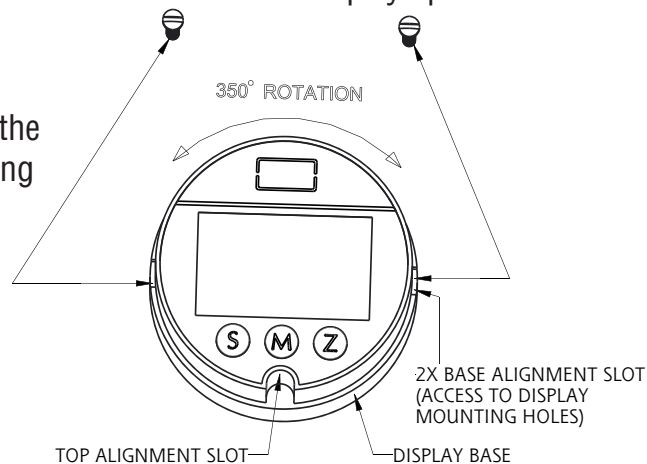

WIRING DIAGRAM 805PT

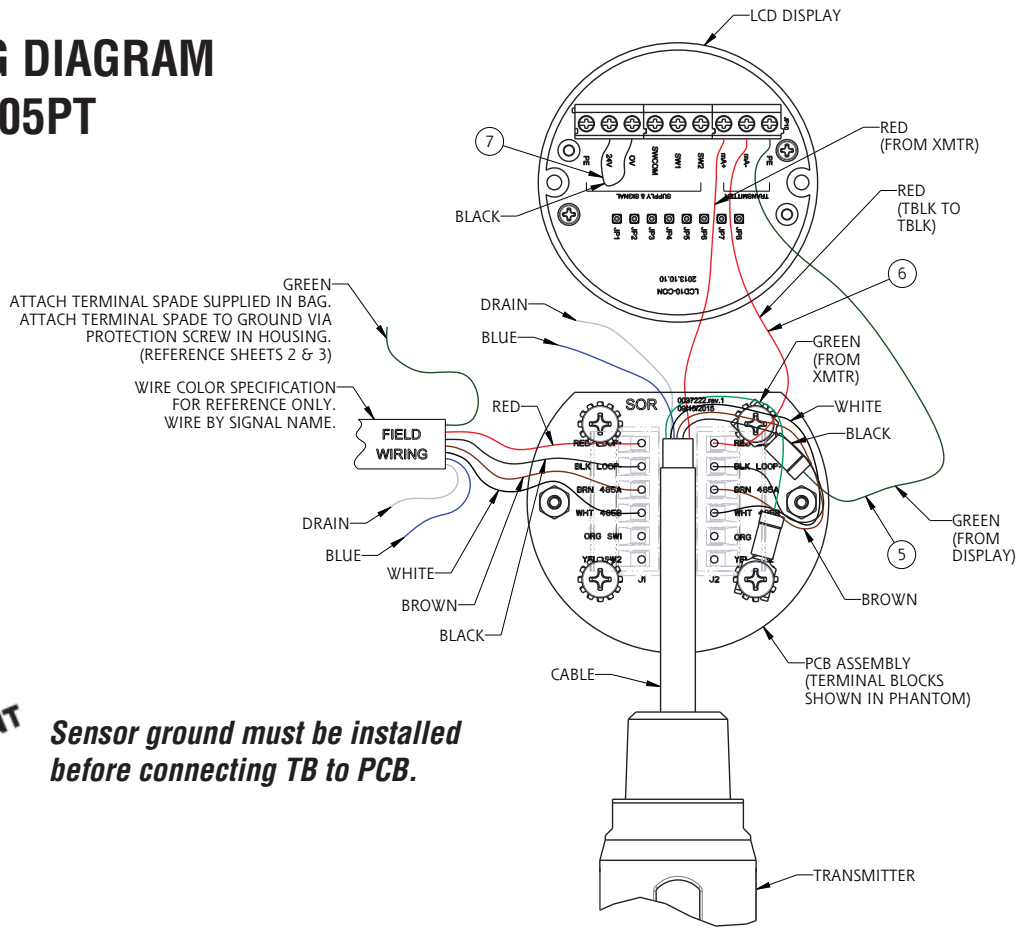

Sensor ground must be installed before connecting TB to PCB.

805QS/815 SERIES

WIRING DIAGRAM 805QS/815 SERIES

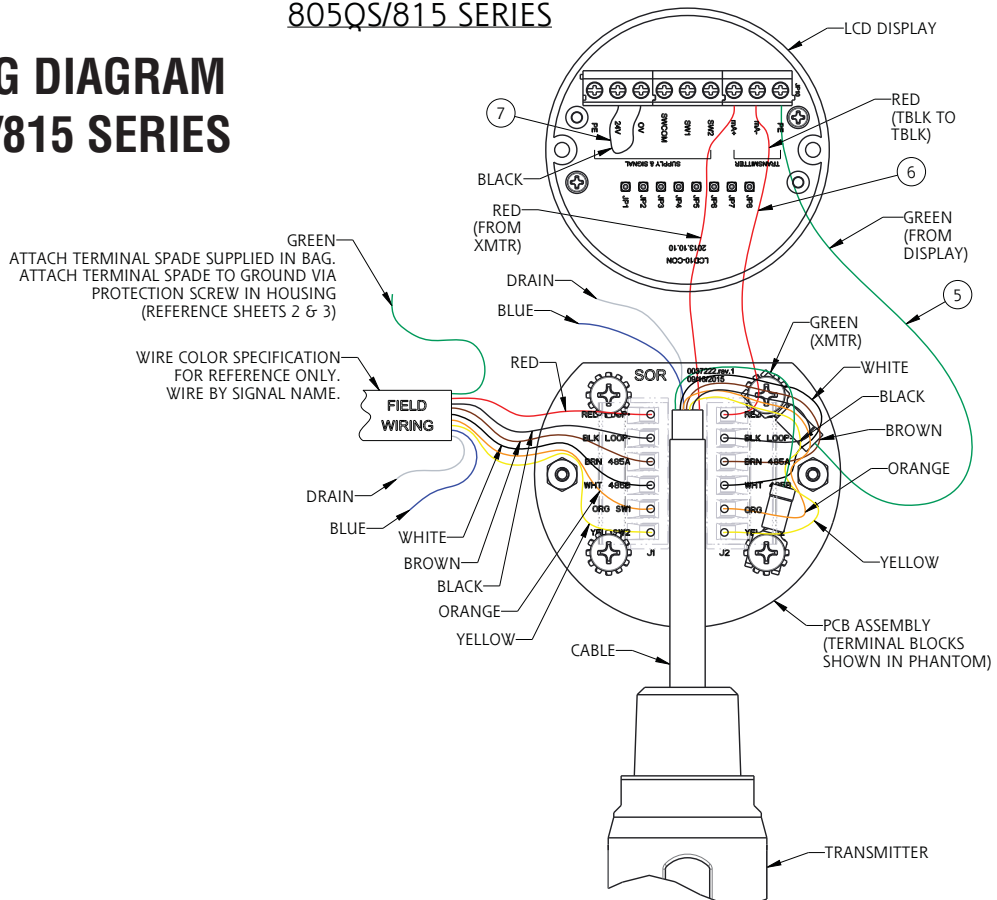

Electrical Termination

If you are using the flying leads provided with the display, see the associated 800 Series General Instructions for wiring information.



The LCD digital indicating display adds an additional 8V loop drop (max).

If you are terminating inside of the display housing, follow the instructions below.

- 1 Unscrew the display housing cover.
- 2 To access terminal connections, rotate the display screen to line up the holes. Using a 1/8" flat screw driver, unscrew the support screws. After one screw has been removed, rotate the screen again to line up the holes on the opposite side in order to remove the second support screw.
- 3 To install field wiring, remove 6 inches of the jacket and foil shield as before.
- 4 Thread the wires and cable through the conduit opening and fish the wires out the front.
- 5 Cut the blue and drain wires, if present, off close to the jacket.
- 6 Strip the remaining wires to approximately 1/4 inch.
- 7 Remove the terminal block plug from the left side of the PCB.

WIRING DIAGRAM 805PT

GREEN
ATTACH TERMINAL SPADE SUPPLIED IN BAG.
ATTACH TERMINAL SPADE TO GROUND VIA
PROTECTION SCREW IN HOUSING.
(REFERENCE SHEETS 2 & 3)

WIRE COLOR SPECIFICATION
FOR REFERENCE ONLY.
WIRE BY SIGNAL NAME.

- 8 With the wire cages facing up and the screws to the left, connect the wires as follows:
 - a. Top opening (loop +) attach red wire.
 - b. Second opening (loop -), attach black wire.
 - c. Third opening (485 A), attach brown wire. 815 only.
 - d. Fourth opening (485 B), attach white wire. 815 only.
 - e. Fifth opening (SW 1), attach orange wire. 815 and 805QS only.
 - f. Bottom opening (SW 2), attach yellow wire. 815 and 805QS only.

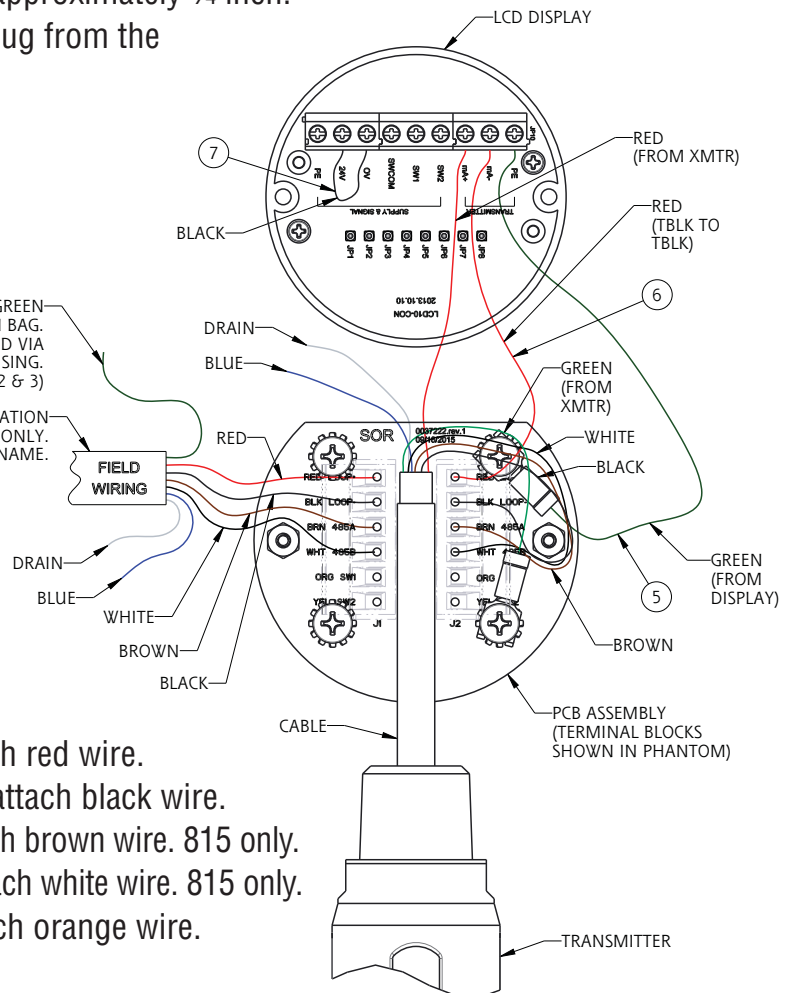

WIRING DIAGRAM 805QS/815 SERIES

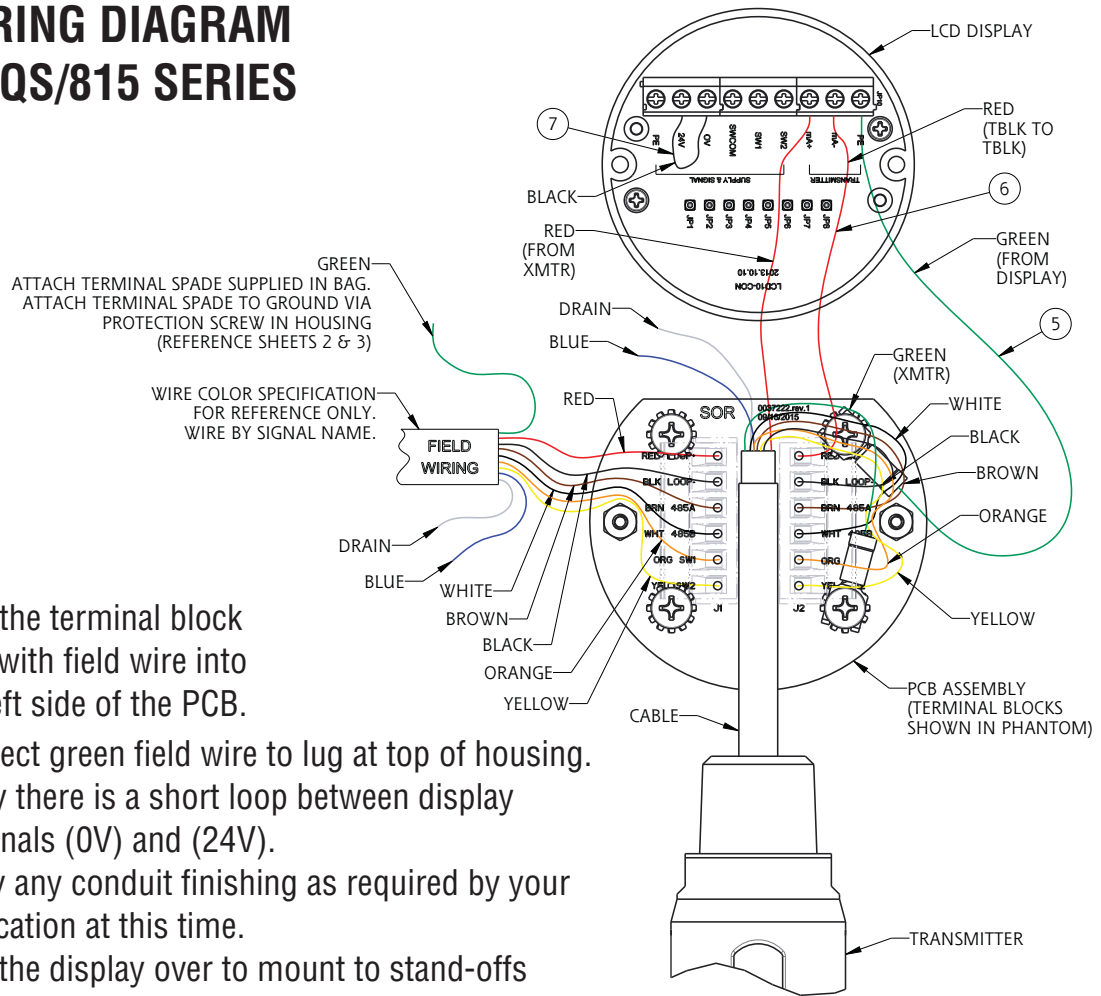

- 9 Plug the terminal block plug with field wire into the left side of the PCB.
- 10 Connect green field wire to lug at top of housing.
- 11 Verify there is a short loop between display terminals (0V) and (24V).
- 12 Apply any conduit finishing as required by your application at this time.
- 13 Turn the display over to mount to stand-offs while carefully pressing the service loops of all wiring to below the tops of the standoffs.
- 14 Reattach display to stand-offs in reverse order of removal so that terminal strip on the back of the display is at the bottom of the housing.



If using field wiring not supplied with the sensor, use the signaling as described in parentheses above. The signal names are also included on the PCB silkscreen for reference. Colors may vary.

Electrical Conduit Connection

- 1 The electrical connection may be installed on an adequately supported rigid conduit system. Use suitable locknuts when mounting instrument to an unthread knockout hole.
- 2 Securely connect the conduit pipe or fitting by holding flats on the electrical connection while tightening.
- 3 Electrical connection may be rigid or flexible conduit.



Units in Hazardous Locations - Prior to removal from service, make sure that the work area is declassified. Failure to do so could result in severe personal injury or substantial property damage.

Setup and Configuration

Display and pressure transmitter are configured separately. The digital indicating display only receives the 4-20mA signal and displays linearized values from user determined lower limit (4mA) and upper limit (20mA) values. To configure the 800 series pressure transmitter, see the respected General Instructions.

The display has 3 buttons. Push “M” to scroll through the display menus, push “Z” to enter and confirm setting change, and push “S” to modify the setting value. The menus are shown in the table below.

Menu Label	Description	Function Instruction
CLK	Unlock screen to be able to customize display outputs	0-255=Locked ; 132=Unlocked ; 12=Restore factory settings
SLL	Set lower range value	-19999-99999
SLH	Set upper range value	-19999-99999
UNI	Set units to be displayed	0=Blank; 1=kPa; 2=MPa; 3=Pa; 4=bar; 5=mbar; 6=psi; 7=mH2O; 8=mmH2O; 9=cmH2O; 10=mmHg; 11=Torr; 12=atm; 13=kg; 14=g; 15=mg; 16=N; 17=kN; 18=°C; 19=°F; 20=K; 21=%RH; 22=%VOL; 23=PPM; 24=%LEL; 25=ph; 26=m; 27=cm; 28=mm; 29=inch; 30=m/s; 31=Ω(ohm); 32=kΩ(kohm); 33=mV; 34=V; 35=L/Min; 36=M3/Hour
DISP	Set display interface value	0=Current value, Percent, and mA; 1=Process Variable, Percentage, and Unit; 2=Percentage, Percentage and %
DECP	Set decimal position	0=None; 1=First Bit; 2=Second Bit; 3=Third Bit; 4=Fourth Bit; Default 2.
PB	Set zero migration	-19999-99999 Default PB=0
KK	Set Range scaling	0-1.9999 times; Default KK=1
AOLC	Input lower limit current alarming value	3.500-3.800mA
AOHC	Input upper limit current alarming value	20.800-24.000mA

- 1 Unlock the screen in order to customize settings
 - a. To unlock the screen, first press the M button. This will take you to the CLK menu
 - b. Press Z to enter setting.
 - c. To unlock the screen, enter the value 132. To restore factory default settings, enter the value 12
 - d. Then modify the paramaters, press the S button. Once the desired value is shown, press Z to confirm and choose the next parameter.
 - e. Once all parameters are set, press the M button to confirm and enter the next menu

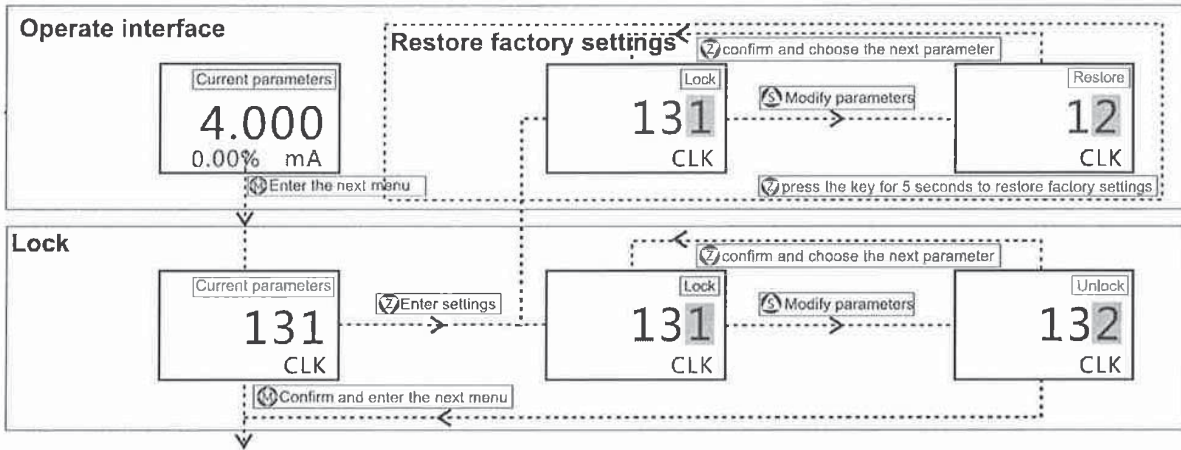

- 2 Select the 4mA corresponding value (0% of span).
 - a. Press Z to enter settings.
 - b. Press S to modify Parameters to desired values.
 - c. Press Z to confirm and choose the next parameter.
 - d. Once all parameters are selected, press the M button to confirm and enter the next menu.



- 3 Select the 20mA corresponding value (100% of span).
 - a. Repeat same steps as in step 2.

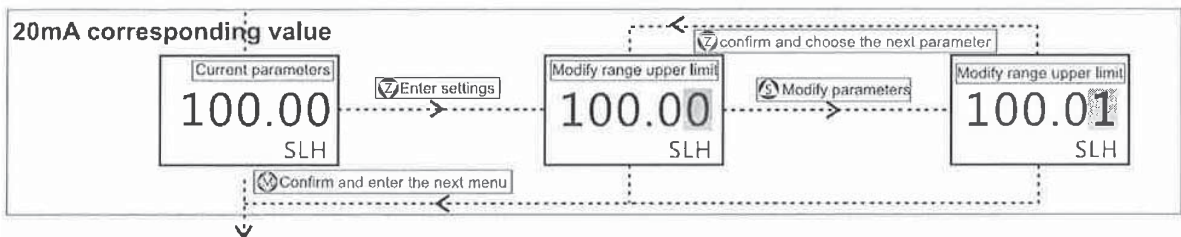

- 4 Select the units of measurement.
 - a. Refer to the table above for unit values
 - b. Repeat same steps as in step 2.

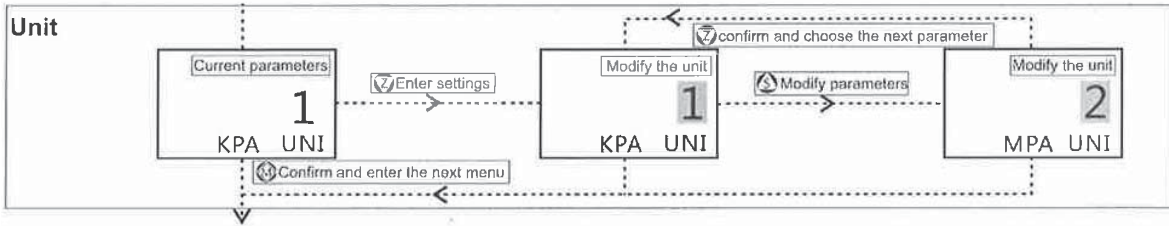

- 5 Set display interface value
 - a. Refer to the table above for display interface values
 - b. Repeat same steps as in step 2.

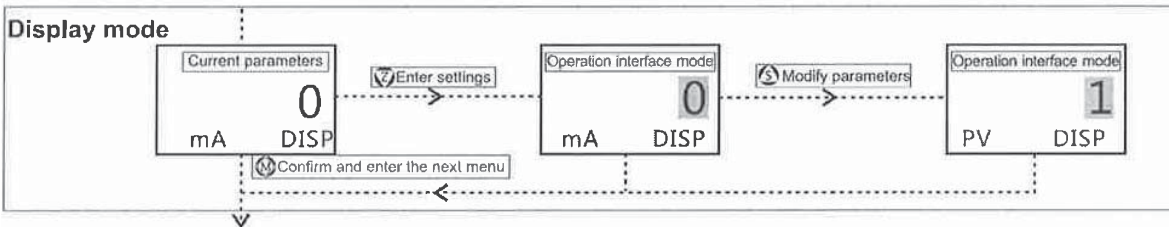

- 6 Select the position of the decimal point.
 - a. Refer to the table above for decimal position values.
 - b. Repeat same steps as in step 2.

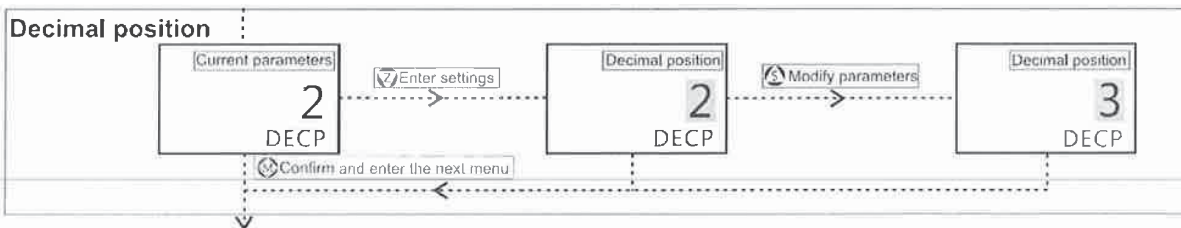

- 7 Select the zero migration
 - a. Repeat same steps as in step 2.

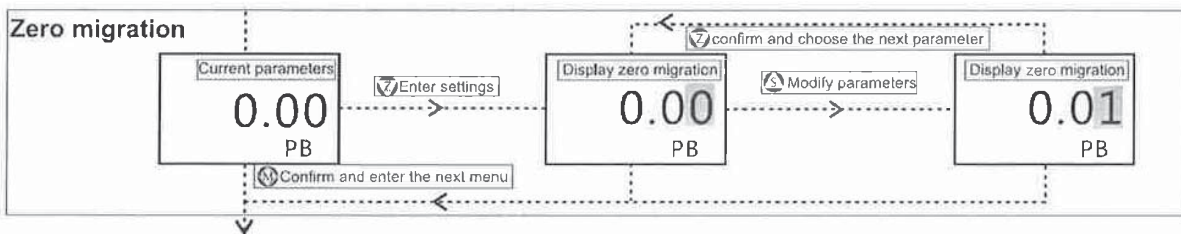

- 8 Set range scaling
 - a. Repeat same steps as in step 2.

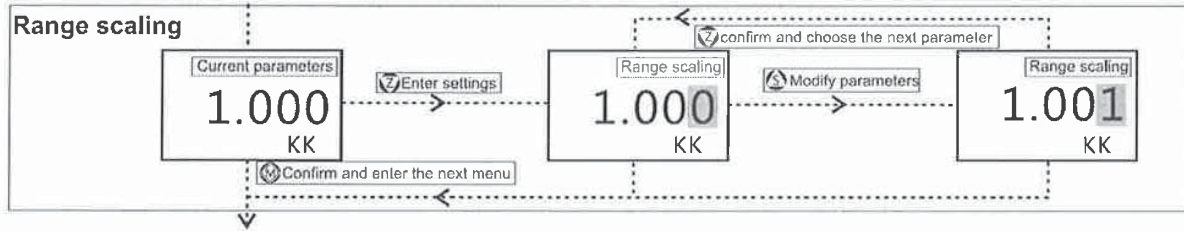

- 9 Input lower limit current alarming value
 - a. To modify, repeat same steps as in step 2.
 - b. Suggested to leave at factory default settings.

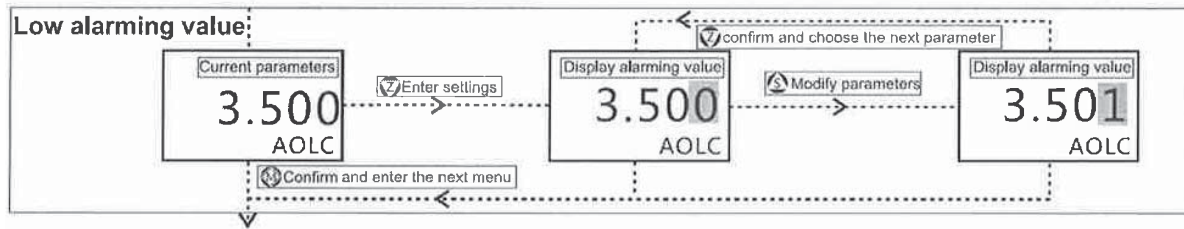

- 10 Input upper limit current alarming value
 - a. To modify, repeat same steps as in step 2.
 - b. Suggested to leave at factory default settings.
 - c. Once Menu is confirmed, you will return the first menu (CLK).
 - d. To lock the screen, select a value between 0-255 that is not 132 or 12.

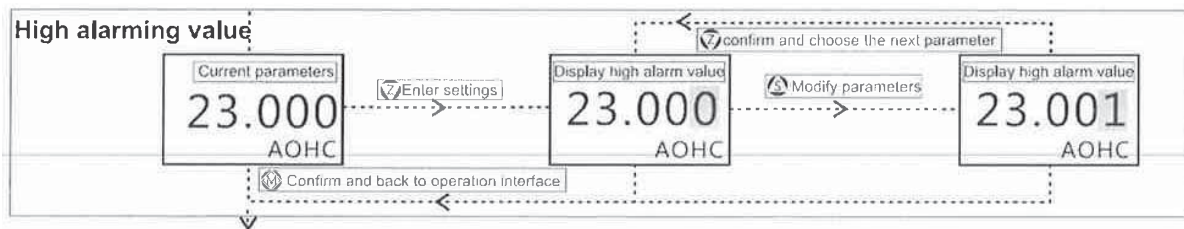

Maintenance

The SOR Digital Indicating Display contains no user serviceable parts and cannot be repaired on site. If display is not functioning correctly, please contact factory for assistance.

Dimensions

805PT/805QS with LCD Display

NOTES:

- 1. DIMENSION APPROXIMATE AND BASED ON A FIVE THREAD ENGAGEMENT.
- 2. TRANSMITTER ORIENTATION MAY VARY IN RELATION TO THE LCD DIGITAL DISPLAY. VARIATION WILL NOT AFFECT FUNCTIONALITY.

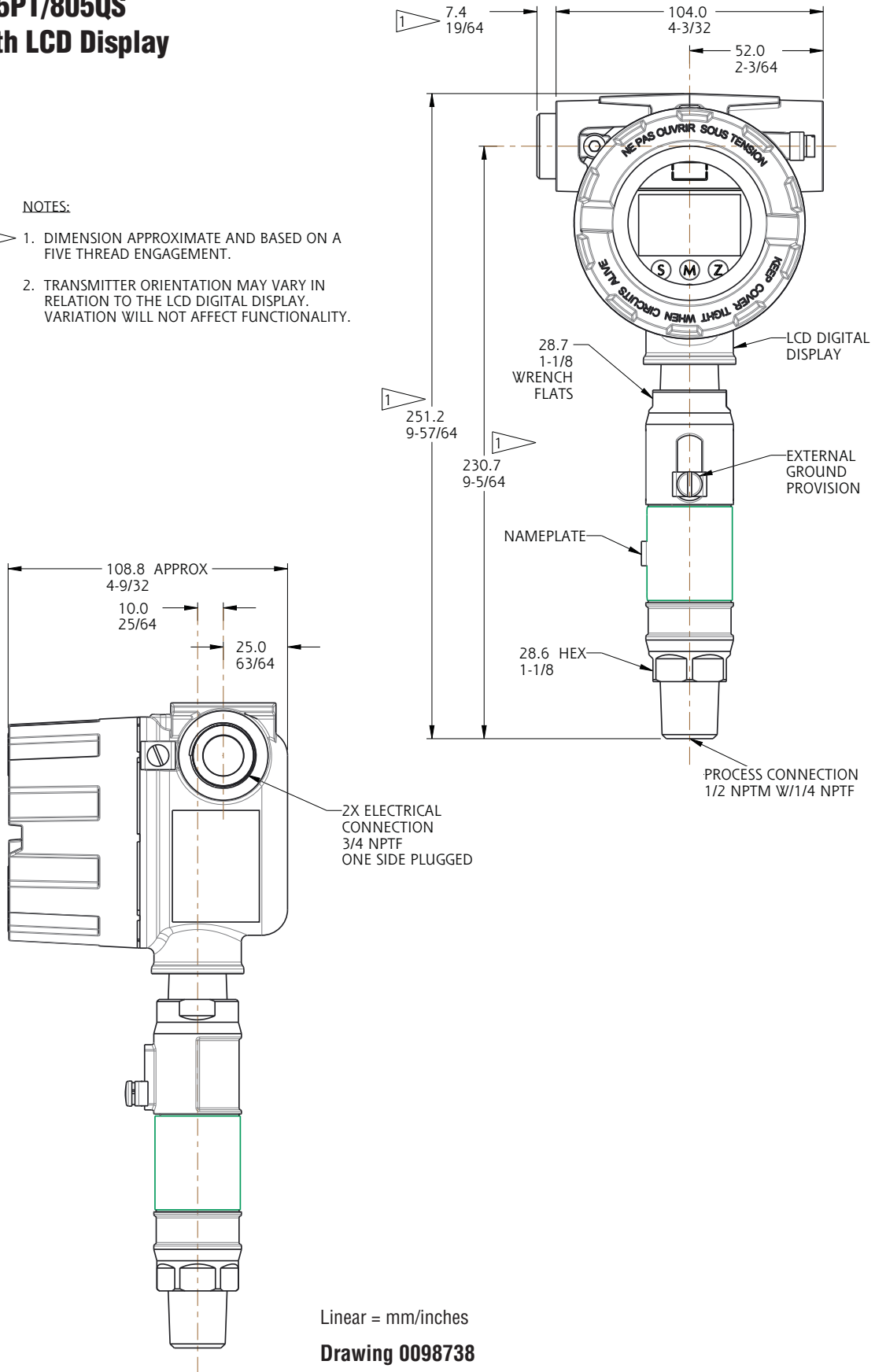

Linear = mm/inches

Drawing 0098738

805PT/805QS with LCD Display and Pipe Kit

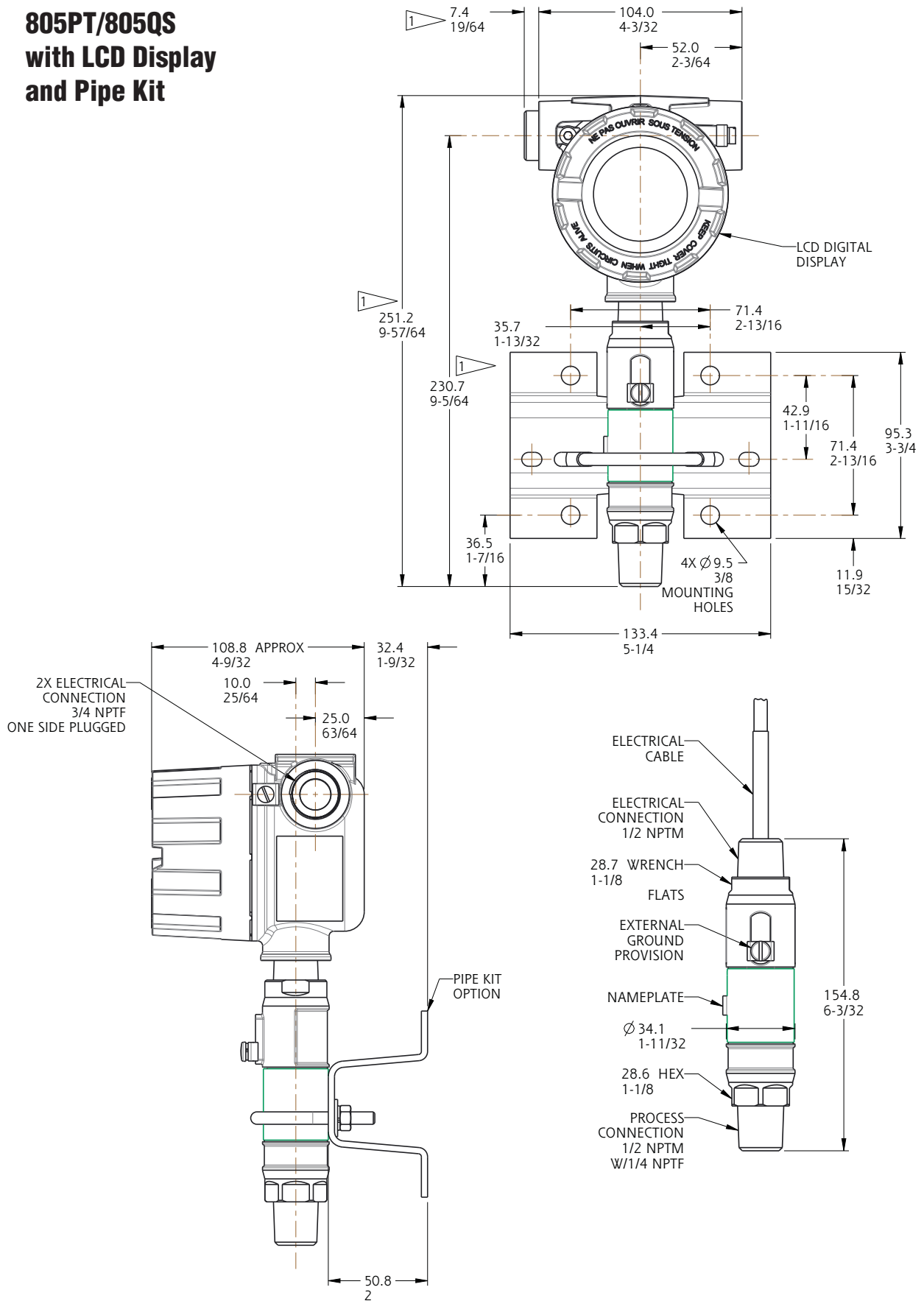

1. DIMENSION APPROXIMATE AND BASED ON A FIVE THREAD ENGAGEMENT.

2. TRANSMITTER ORIENTATION MAY VARY IN RELATION TO THE LCD DIGITAL DISPLAY. VARIATION WILL NOT AFFECT FUNCTIONALITY.

Linear = mm/inches

Drawing 0098745

815PT with LCD Display

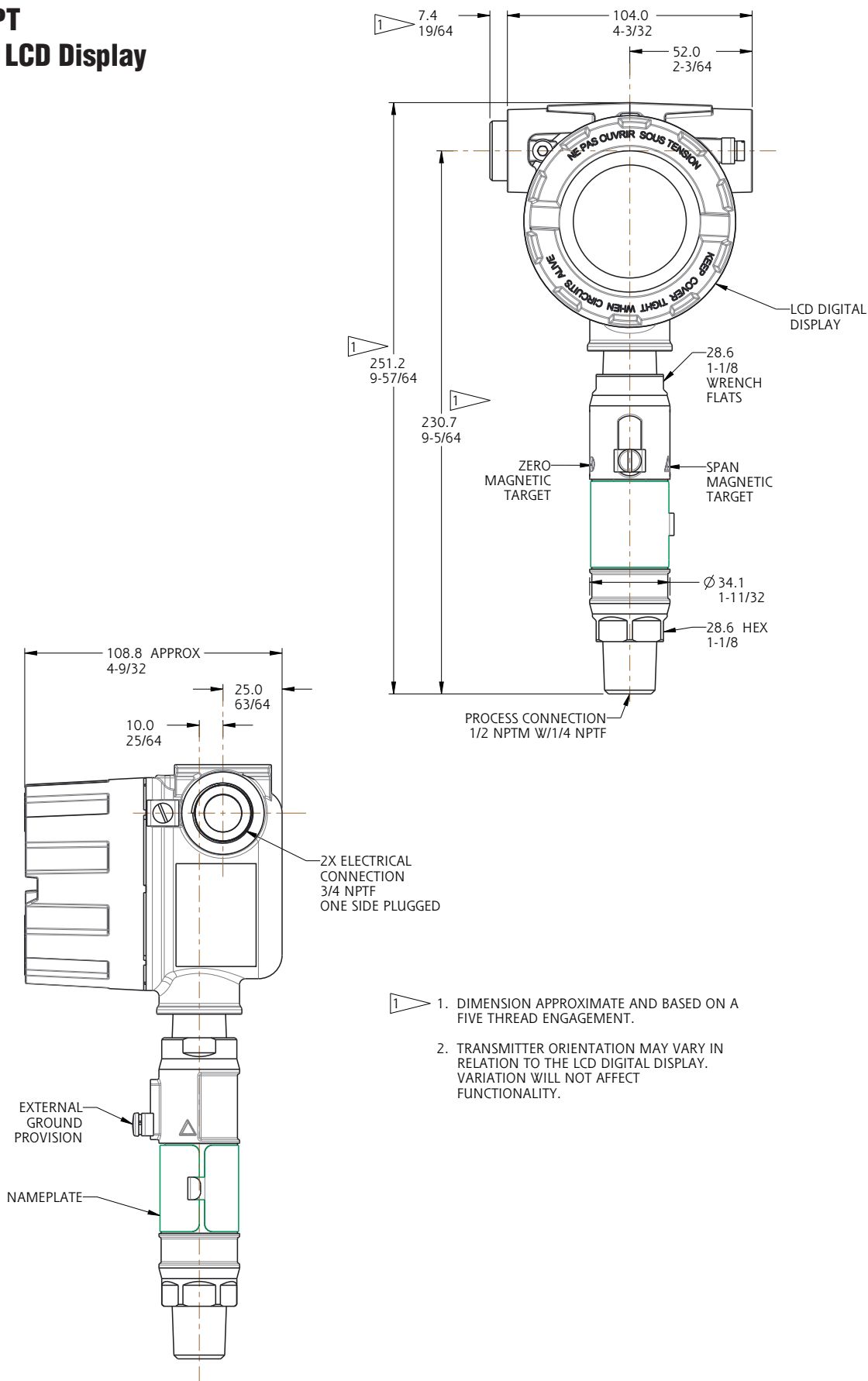

1. DIMENSION APPROXIMATE AND BASED ON A FIVE THREAD ENGAGEMENT.
2. TRANSMITTER ORIENTATION MAY VARY IN RELATION TO THE LCD DIGITAL DISPLAY. VARIATION WILL NOT AFFECT FUNCTIONALITY.

Linear = mm/inches

Drawing 0098750

815PT with LCD Display and Pipe Kit

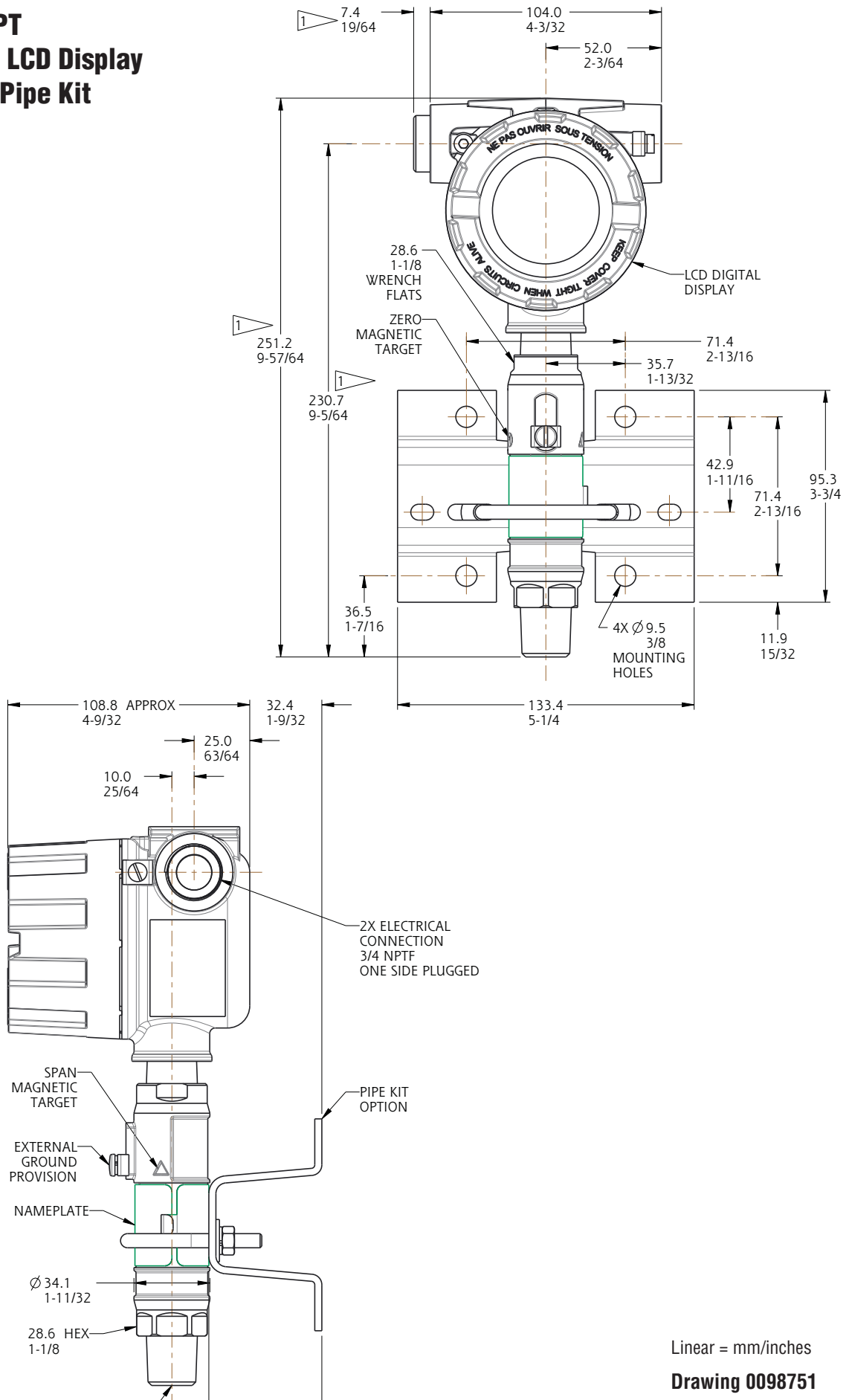

Linear = mm/inches

Drawing 0098751

815DT with LCD Display

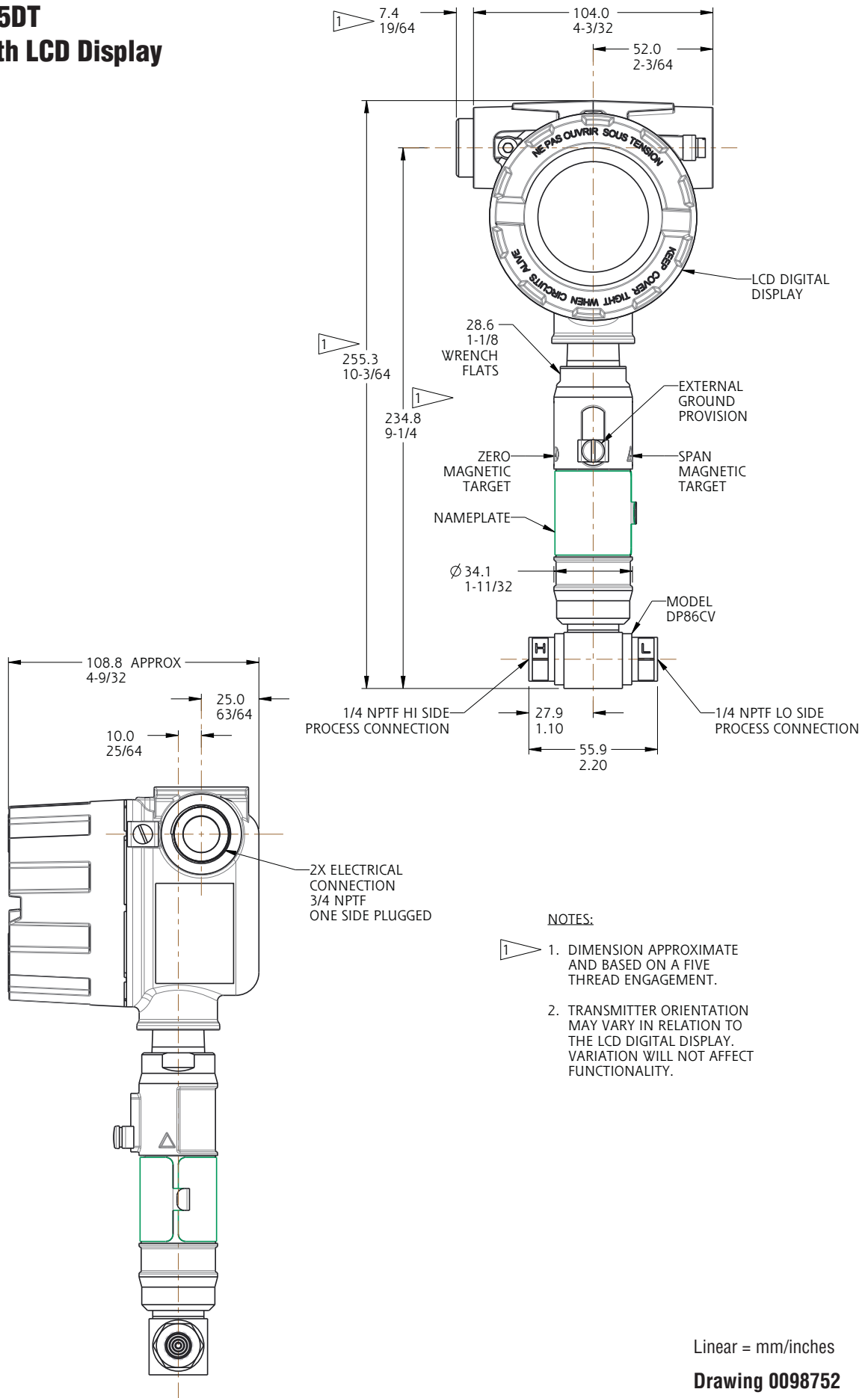

NOTES:

- 1. DIMENSION APPROXIMATE AND BASED ON A FIVE THREAD ENGAGEMENT.
- 2. TRANSMITTER ORIENTATION MAY VARY IN RELATION TO THE LCD DIGITAL DISPLAY. VARIATION WILL NOT AFFECT FUNCTIONALITY.

Linear = mm/inches

Drawing 0098752

815DT with LCD Display and Pipe Kit

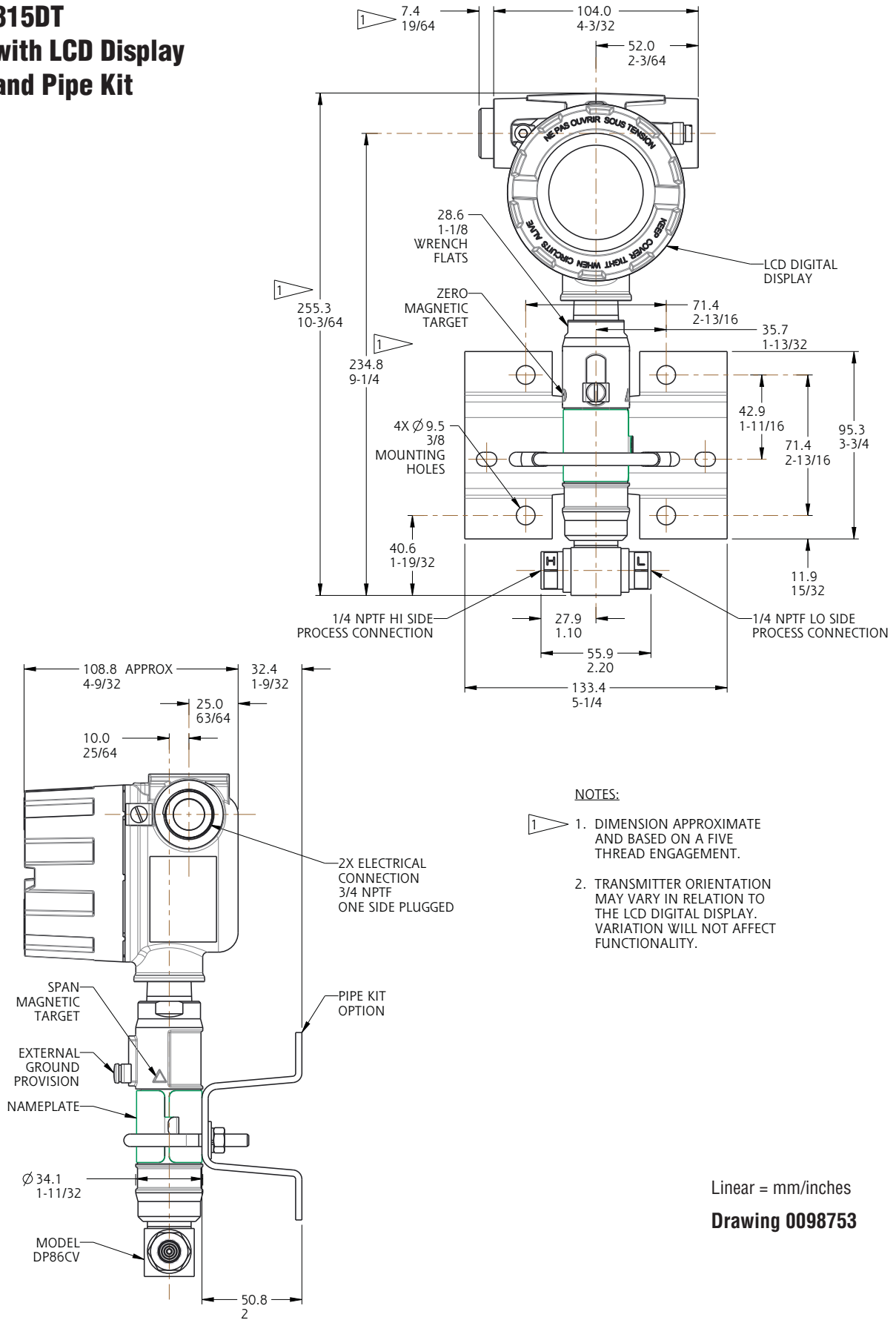

Linear = mm/inches

Drawing 0098753

“RD” Remote Display Option

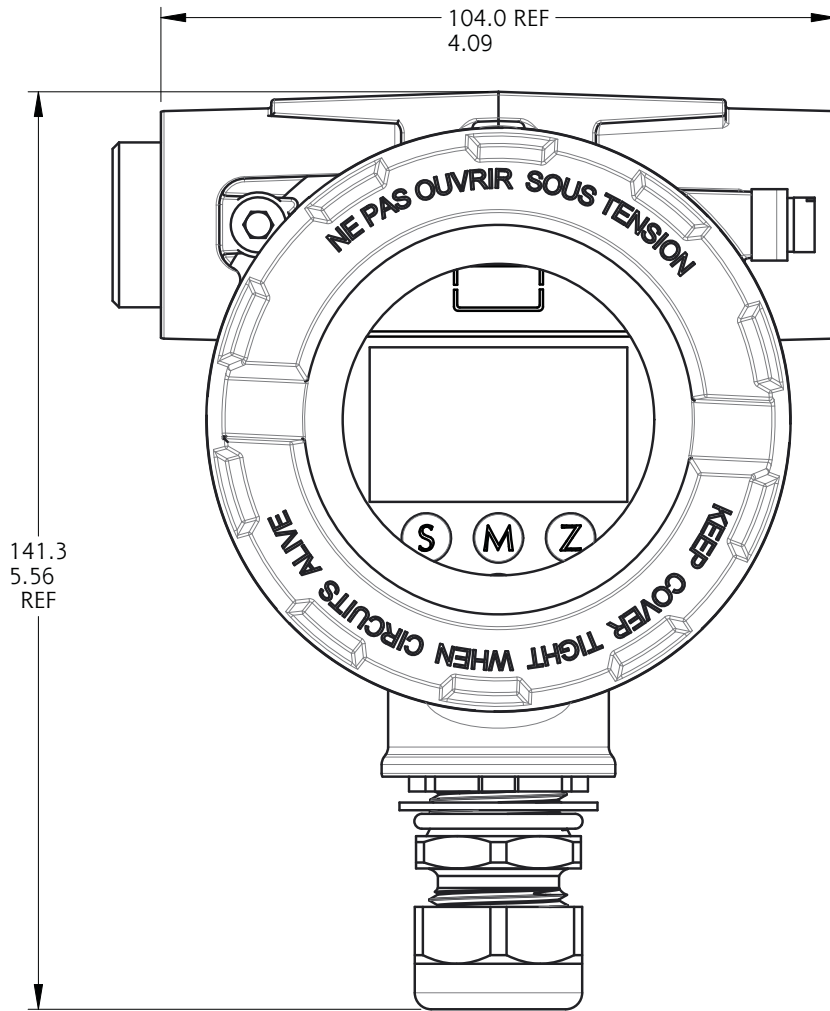

Linear = mm/inches

Drawing 9231674



SORInc.com

14685 West 105th Street, Lenexa, KS 66215 ■ 913-888-2630 ■ 800-676-6794 USA ■ Fax 913-888-0767