



## Series 900 Flow Detectors

### General Instructions

This device is intended as a flow/no-flow device only. It is not recommended for use as an accurate measurement device. The Series 900 Flow Detector is designed for vertical mounting only.

**NOTE:** *If you suspect that a product is defective, contact the factory or the SOR® Representative in your area for a return authorization number (RMA). This product should only be installed by trained and competent personnel.*

### Installation

#### Step 1 - Vane Length

Vane clearance is critical for proper operation of the detector. In order to ensure this clearance, the following procedure should be followed:

- 1 Measure "C" on the existing pipe run (See **A** on page 2).
- 2 Trim vane (if necessary) to ensure a minimum of 3/16" vane clearance when installed. Allow for thread engagement.



*If vane is removed from unit for trimming, proper re-assembly is essential, keeping small vane in its original position (See **B** on page 2).*



#### Step 2 - Installation

- 1 Thread bushing into pipeline coupling and align arrows in direction of flow. (Arrows are located on fitting.)

#### Step 3 - Flow Adjustment

The flow rate on each detector may be externally adjusted following this procedure:

- 1 Remove the detector housing cover.
- 2 Remove the hex head plug located at the end of the enclosing tube (See **C** on page 2).
- 3 Adjust the detector adjustment screw to the flow required. To increase detecting flow rate, turn screw clockwise. Maximum flow adjustment is approximately 10 turns.

*Design and specifications are subject to change without notice.  
For latest revision, go to [www.sorinc.net](http://www.sorinc.net)*



**The safety retaining ring prevents accidental removal of the detector adjustment screw. Do not use force to unscrew the adjustment screw since the sudden release of the adjustment screw under pressure could cause injury to the person adjusting the detector.**

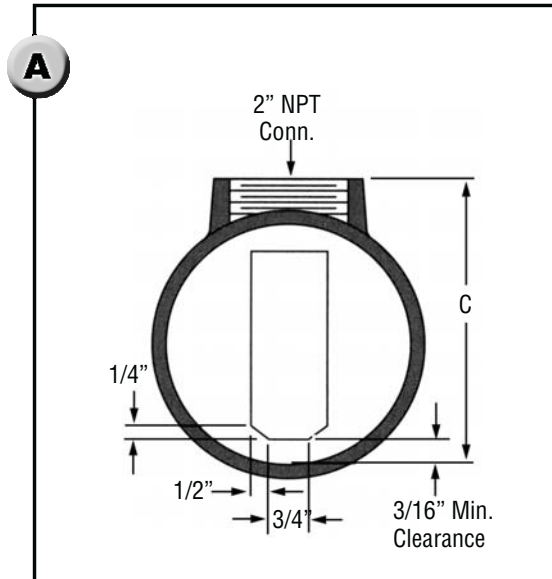

**Threaded connection shown**

*Dimensions are for reference only. Contact the factory for certified drawings for a particular model number.*

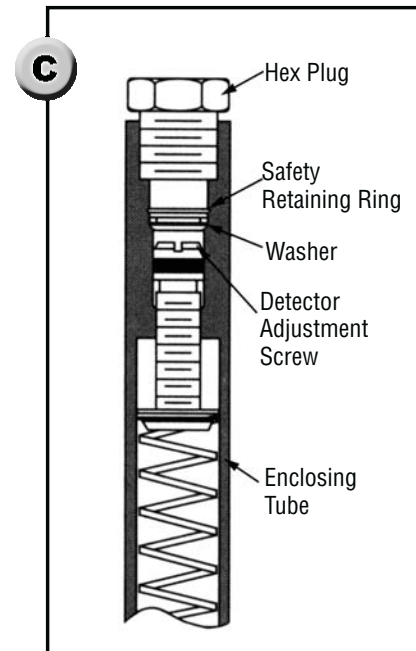
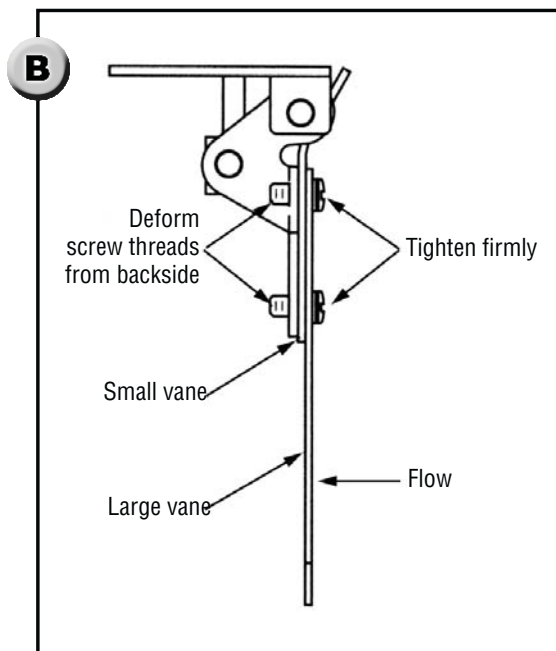

## **Safety Integrity Level (SIL) Installation Requirements**

The SOR pressure detectors have been evaluated as Type-A safety related hardware. To meet the necessary installation requirements for the SIL system, the following information must be utilized:

- Proof Test Interval shall be one year.
- Units may only be installed for use in Low Demand Mode.
- Products have a HFT (Hardware Fault Tolerance) of 0, and were evaluated in a 1oo1 (one out of one) configuration.

Form 1538 (03.12) ©2012 SOR Inc.

## Process Connection

Integrally mounted controls should be mounted with the vessel flange or nozzle within 3° of the vertical or horizontal centerline of the vessel, as applicable.

Control should be mounted with ten diameters (pipe ID x 10) length straight, unrestricted pipe on both sides.

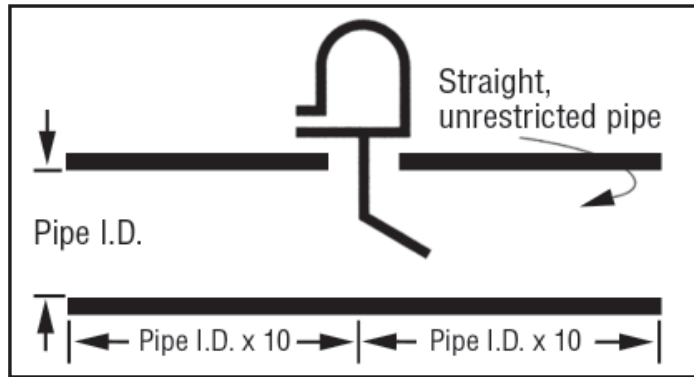

Insulation of the control is not recommended.

## Electrical Connection



***Electrical power must be disconnected from explosion proof models before the cover is removed. Failure to do so could result in severe personal injury or substantial property damage.***

Ensure that wiring conforms to all applicable local and national electrical codes and install unit(s) according to relevant national and local safety codes.

Detector housing conduit connections can be rotated 360° by loosening the set screw located under the housing base. Do not attempt to rotate the housing without loosening set screw. Retighten the set screw after adjusting the housing.

Care must be taken in positioning the incoming wiring to ensure clearance between the wiring and detector housing. Detector wiring should be brought through the conduit connection, under the baffle plate, wrapped around the sealing tube and brought up to the proper terminal. All excess wire should be cut off prior to stripping the wire to avoid interference with the action of the detector mechanism or housing cover.

All housings must be properly “sealed” at the conduit connection to maintain the NEMA classification.

Check housing-to-base fit to ensure the gaskets are sealing properly.

# Wiring Continuity



*Do not change factory-set detecting element positions during installation.*

Vane Position	SPDT Mechanism	DPDT Mechanism
		<p style="text-align: center;">SOR Control Devices</p>
		<p style="text-align: center;">SOR Control Devices</p>



Printed in USA

sorinc.net

14685 West 105th Street, Lenexa, KS 66215 ■ 913-888-2630 ■ 800-676-6794 USA ■ Fax 913-888-0767