



General Instructions

These instructions provide information for the installation and field calibration of SOR® B & J Pressure Detectors.

The pressure sensing element of the SOR B & J pressure detector is a force-balanced piston-actuated assembly sealed by a flexible diaphragm and an o-ring that is static. The only wetted parts in this arrangement are: the pressure port, the diaphragm and o-ring. An optional welded pressure port and diaphragm assembly eliminates the o-ring. A wide selection of wetted parts materials is available for compatibility with the process media.

Media pressure on the piston counteracts the force of the adjustable range spring, which moves the piston shaft only a few thousandths of an inch to directly actuate the electrical detecting element.

NOTE: If you suspect that a product is defective, contact the factory or the SOR Representative in your area for a return authorization number (RMA). This product should only be installed by trained and competent personnel.

Installation

B & J pressure detectors may be secured to bulkheads, panels or pipe stanchions with suitable bolts.



Failure to mount the housing on a flat mounting surface may result in torsional forces on the housing that could cause false trips or render the pressure detector inoperative.

Line mounting by either the process connection or the electrical conduit connection is NOT recommended.

Table of Contents

Design and specifications are subject to change without notice.

For latest revision, go to www.sorfinc.net

Installation	1
SIL Installation	2
Process Connection	2
Electrical Connection.....	3
Calibration	4
ATEX Marking Details	4
Operation.....	5-7
Declaration of Conformity	8

Safety Integrity Level (SIL) Installation Requirements

The SOR pressure detectors have been evaluated as Type-A safety related hardware. To meet the necessary installation requirements for the SIL system, the following information must be utilized:

- Proof Test Interval shall be one year.
- Units may only be installed for use in Low Demand Mode.
- Products have a HFT (Hardware Fault Tolerance) of 0, and were evaluated in a 1001 (one out of one) configuration.

Form 1538 (03.12) ©2012 SOR Inc.

Process Connection

Securely connect the process line to the pressure connection using two wrenches; one to hold the wrench flats on the pressure port, the other to tighten the process pipe or tube fitting.



Ensure that the process connection is tightened and positioned so that bending and torsional forces imposed on the pressure detector are minimal. Do not loosen the pressure port from the body or the body from the housing, because leakage could result or the pressure detector could be rendered inoperative.



One vent connection should be fitted with a suitable breather to maintain weathertight rating NEMA 4, 4X, IP65 or vented to a safe area. Piping should be minimum 1/4" diameter and maximum 5 meters long (based on process fluid SG 1.0). The other vent connection may be plugged.

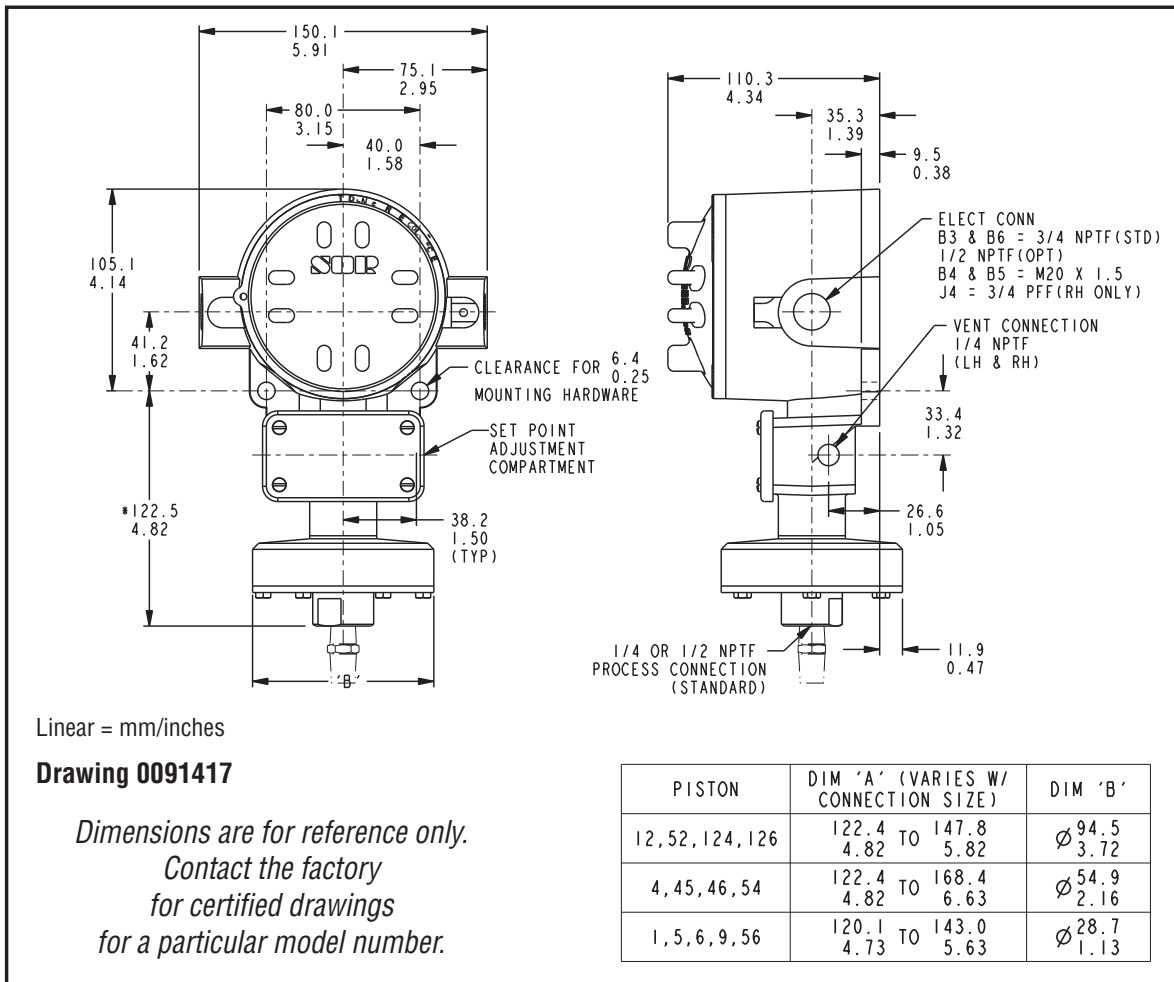

Electrical Connection

Ensure that wiring conforms to all applicable local and national electrical codes and install unit(s) according to relevant national and local safety codes.

NOTE: For ATEX Certified Models: Electrical conduit connection threads may be of non-ISO thread form. Check the product nametag for relevant thread form information before attempting to connect to the electrical conduit connection. In the event a fitting is used, check the adapter body for thread size information.

Standard electrical connection is a terminal block.

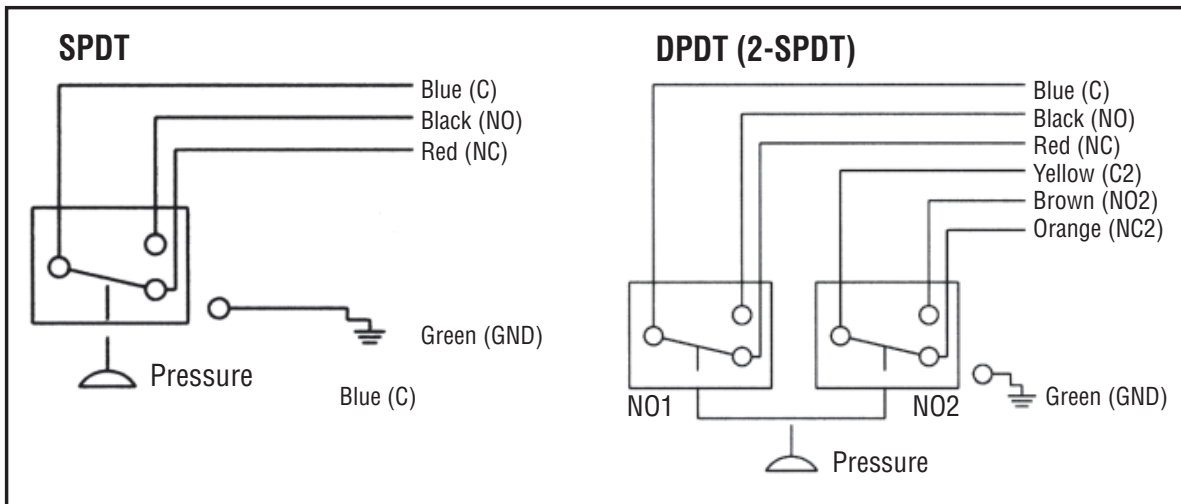

B-series is 6-place compression type; J4 is 6-place screw type. The terminal block is marked: Common (C), Normally Open (NO), Normally Closed (NC). If DPDT is specified, additional markings are: Common 2 (C-2), Normally Open 2 (NO-2), and Normally Closed 2 (NC-2).



Overtravel has been preset at the factory, i.e. the detecting element assembly has been precisely positioned in the housing for optimum performance. It normally should not be changed in the field. Should adjustment be necessary, factory approved procedures must be closely followed. Any inadvertent movement or replacement in the field will degrade performance, void the warranty and could render the device inoperative, unless factory approved procedures are followed.

NOTE: Internal primary equipment ground (earth) screw must be used for the equipment ground connection and the external supplemental ground screw is provided for safety and compliance with specific code requirements.



The electrical compartment cover must remain sealed and the Allen locking screw tightened at all times to prevent removal of the cover while the pressure detector is in service.



Electrical power must be disconnected from explosion proof models before the cover is removed. Failure to do so could result in severe personal injury or substantial property damage.

Calibration

- 1 Remove the set point adjustment compartment cover.
- 2 To increase the set point at which the detecting element actuates, turn the hex adjusting nut clockwise with a 3/4-inch open-end wrench.
- 3 Sight across the flat top of the adjusting nut to the calibration scale at the bottom of the housing for an approximate set point. Use a 1/4% external pressure gauge to more precisely calibrate the pressure detector.
- 4 Replace the set point adjustment compartment cover. The pressure detector can be placed in service.

NOTE: The set point adjustment compartment is separate from the electrical compartment. The set point may be changed without disconnecting electrical power.

ATEX Marking Information

For ATEX Certified Models

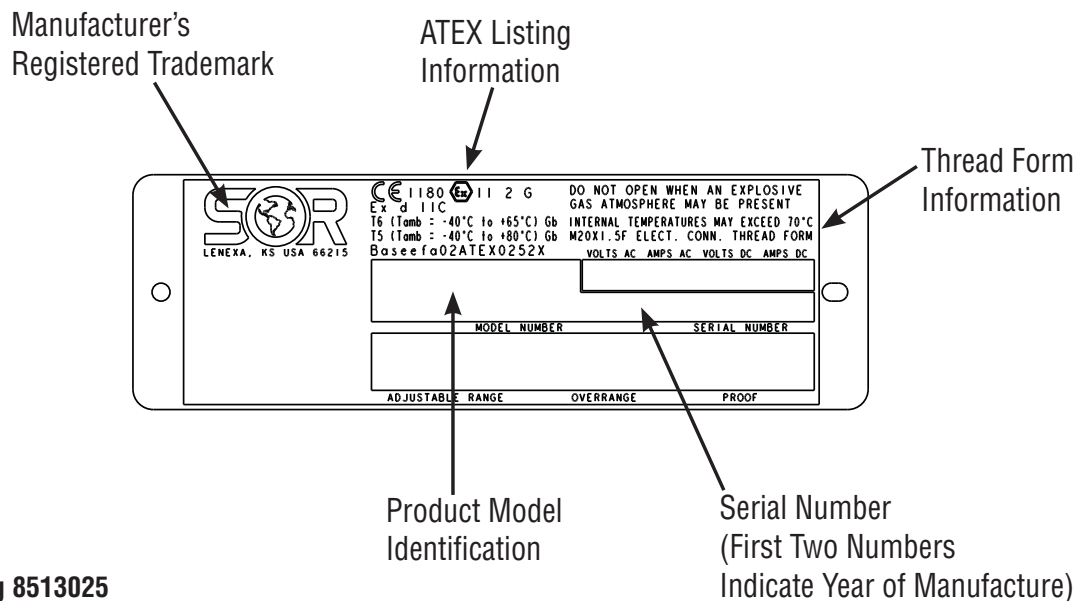

Drawing 8513025

Special Conditions for Safe Use

To minimize the risk of electrostatic discharge, clean only with a damp cloth.

Operation

For ATEX Certified Models

Maximum Surface Temperature

T6 Rating - 85°C

T5 Rating - 100°C

Regular Pressure

Piston-Spring Designators	Adjustable Range		Overrange		Proof	
	psi (in. wc)	bar [mbar]	psi	bar	psi	bar
12 - 66	(0.6 to 2.5)	[1.5 to 6.2]	200	14	400	28
12 - 614	(2.5 to 45)	[6.2 to 110]				
12 - 2	0.4 to 2.0	[30 to 140]				
12 - 4	0.5 to 6.0	[35 to 415]				
12 - 5	0.75 to 12	[50 to 830]				
12 - 45	1 to 16	[70 to 1100]				
4 - 2	2 to 8	[140 to 550]	750	50	1000	70
4 - 4	2 to 25	0.14 to 1.7				
4 - 5	3 to 50	0.2 to 3.5				
4 - 45	4 to 75	0.3 to 5				
6 - 2	7 to 30	0.5 to 2				
6 - 3	12 to 100	0.8 to 7	1500	100	2500	170
6 - 5	20 to 180	1.4 to 12				
6 - 45	25 to 275	1.7 to 19				
5 - 3	25 to 240	1.7 to 16				
5 - 5	35 to 375	2.4 to 26				
5 - 45	45 to 550	3.1 to 38				
9 - 4	100 to 500	7 to 35				
9 - 5	200 to 1000	14 to 70				
9 - 45	200 to 1750	14 to 120				
1 - 45	500 to 4000	35 to 275	5000	340	6000	410

Vacuum

Piston-Spring Designators	Adjustable Range (Vacuum - 0 - Pressure)		Overrange		Proof	
	in. Hg (in. wc)	bar [mbar]	psi	bar	psi	bar
52 - 116	(20 - 0 - 20)	[50 - 0 - 50]	200	14	400	28
52 - 117	(40 - 0 - 40)	[100 - 0 - 100]				
54 - 117	15 - 0 - 15	0.5 - 0 - 0.5	750	50	1000	70
54 - 118	30 - 0	1.0 - 0				
56 - 216	30 - 0 - 20	1.0 - 0 - 0.7	1500	100	2500	170
56 - 316	30 - 0 - 160	1.0 - 0 - 5.4				

Pivot Seal

Piston-Spring Designators	Adjustable Range		Overrange		Proof	
	psi	bar	psi	bar	psi	bar
2 - 3	100 to 1900	7 to 130	8000	550	10,000	700
2 - 5	500 to 3000	35 to 210				
3 - 45	1000 to 7000	70 to 480				

Designator		AC Rating		DC Rating Resistive			
SPDT	DPDT	Volts	Amps	Volts	Amps	Volts	Amps
K	KK	24	15	-	-	-	-
KA	-	24	1	-	-	-	-
J	JJ	24	1	-	-	24	1
G	GG	24	15	24	0.5	-	-
A	AA	24	11	-	-	24	5
L	LL	24	15	24	0.5	-	-
E	EE	24	5	-	-	-	-
C	-	24	15	24	0.5	-	-
S	-	24	10	24	1.5 min. 10.0 max.	-	-
B	BB	24	5	24	0.3	-	-
Y	YY	24	5	-	-	-	-
W	-	24	5	-	-	-	-
N	-	24	10	-	-	-	-
T	-	24	15	-	-	-	-
H	-	24	15	-	-	-	-
AF	AG	24	11	-	-	24	5
EF	EG	24	5	-	-	-	-
JF	JG	24	1	-	-	24	1

Declaration of Conformity

For ATEX Certified Models

EC Declaration of Conformity		CE
Product	B Series Pressure and Temperature Detectors	
Manufacturer	SOR Inc. 14685 West 105 th Street Lenexa, Kansas 66215-2003 United States of America	
Date of Issue	July 16, 2012	
We declare that the above products conform to the following specifications and directives	ATEX Directive (94/9/EC) Equipment Intended for use in Potentially Explosive Atmospheres EN 60079-0:2009 EN 60079-1:2007	
Carries the marking	 II 2 G Ex d IIC T6 Gb (Tamb = -40°C to +65°C) or T5 (Tamb = -40°C to +80°C)	
Reference document	EC-Type Examination Certificate Baseefa02ATEX0252X Issued May 7, 2003	
ATEX Notified Body	Baseefa Ltd. (Notified Body No. 1180) Rockhead Business Park, Staden Lane, Buxton, Derbyshire SK17 9RZ United Kingdom Baseefa Customer Reference No. 1021	
Persons responsible	John J. Fortino (VP of Engineering)	

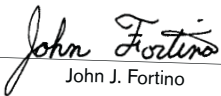
John J. Fortino

Engineered to Order with Off-the-Shelf Speed

 14685 West 105th Street, Lenexa, KS 66215-2003
913-888-2630 • 800-676-6794 USA • 913-888-0767 FAX

Form 1380 (08.12) ©2012 SOR Inc. (Printed in USA)

Printed in USA



sorinc.net

14685 West 105th Street, Lenexa, KS 66215 ■ 913-888-2630 ■ 800-676-6794 USA ■ Fax 913-888-0767

8/8 Registered Quality System to ISO 9001

Form 316 (01.13) ©SOR Inc.