

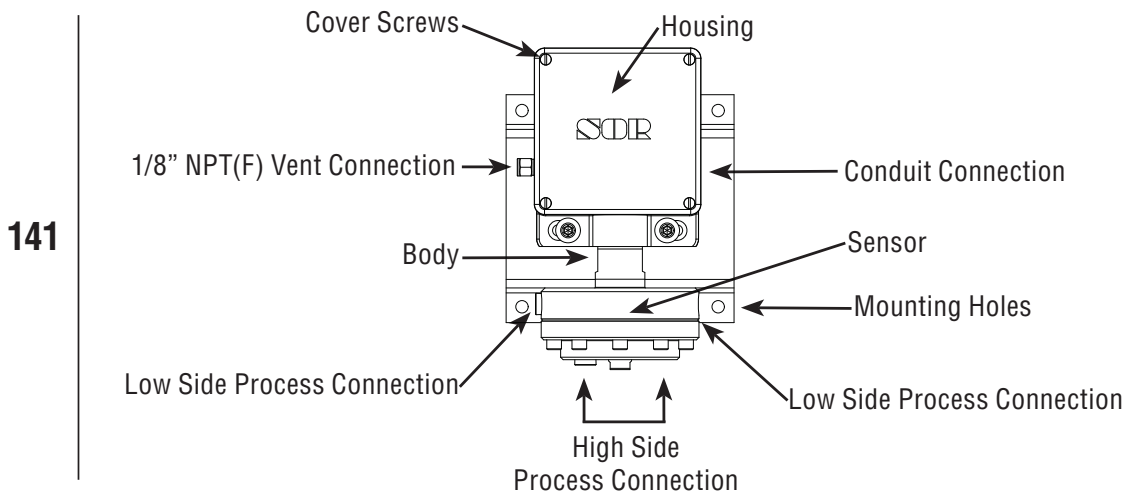

131/141 Nuclear-Qualified Differential Pressure Switches with Terminal Block

General Instructions

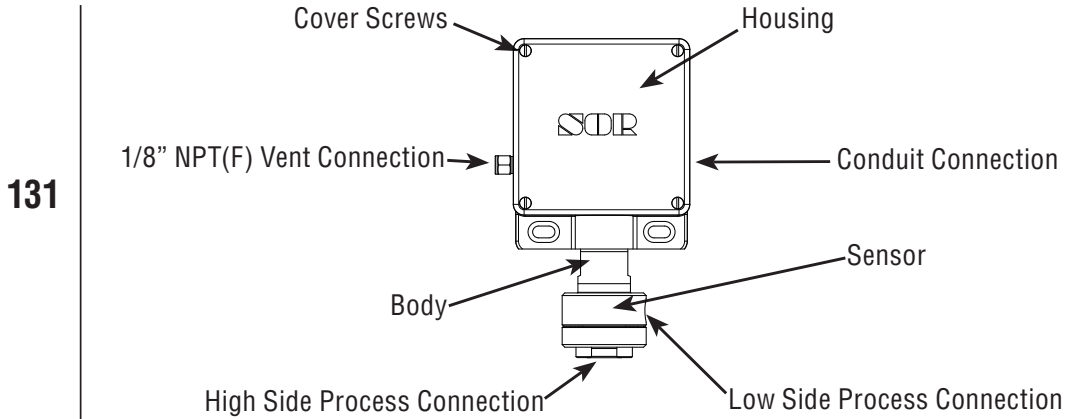

NOTE: If you suspect that a product is defective, contact the factory or the SOR® Representative in your area for a return authorization number (RMA). This product should only be installed by trained and competent personnel.

Installation

Mount differential pressure switch to rigid vertical mounting surface with four 1/4-28 Grade 5 bolts and lock washers (not supplied). Torque bolts to 9 ft-lbs. The 141 must be oriented with the sensor down (housing up).

*Design and specifications are subject to change without notice.
For latest revision, go to www.sorinc.com*

Process Connection

Be certain the process connection is tightened and positioned so bending and torsional forces imposed on pressure switch are minimal. Use care not to loosen sensor assembly from housing.

131 - One process connection is provided for the high-pressure side of the device and one for the low-pressure side.

141 - Two process connections are provided for the high-pressure side of the device and two for the low-pressure side. On liquid service, the extra process connections should be used to assist in bleeding the air out of the sensor. On gas service, they may be used to drain condensate or accumulated liquid.



When the process could be considered dirty in terms of suspended particles, it is recommended that 20-micron in-line filters be installed on the Hi and Lo pressure ports.

Electrical Connection

- Conduit should be installed without applying strain to the housing.
- Screw terminal block is provided with marked insulation as denoted below.
- Ensure the use of insulated terminal connectors when installing field wiring.
- Tighten screw terminals to 10 in-lbs. (1.1 N-m).

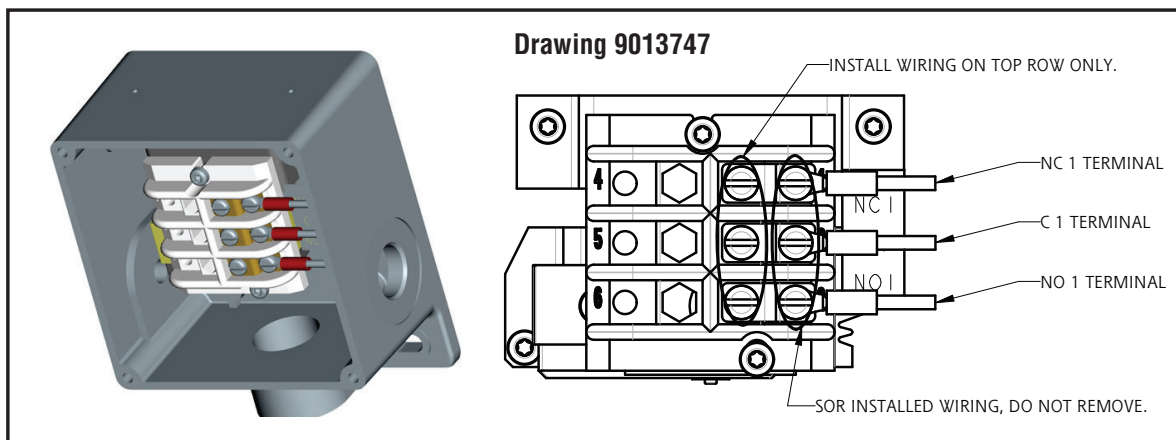
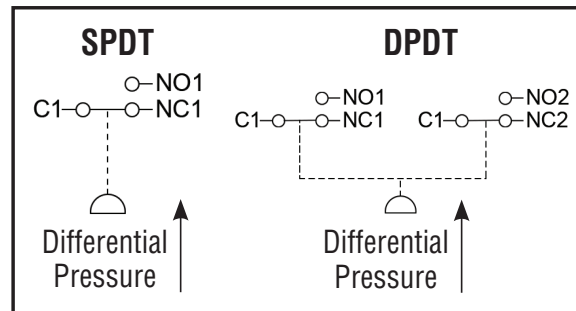

Site Storage

Store switch in a dry area in the original shipping package. Shelf life is 10 years for a maximum ambient temperature of 80°F, based on aging data in SOR Test Report 9058-102.

Calibration

This instrument may be calibrated as a pressure switch (low side vented); however, for best performance, calibrate under simulated operating conditions.

The 131 has a static shift of -1 psi per 100 psi applied static. If the unit is calibrated without static pressure applied, the set point should be adjusted to counter the actual static pressure.

To check the set point of a switch, monitor either the common (C) and normally open (NO) or the common (C) and normally closed (NC) contacts for change of state. Connect the process connection to a regulated hydraulic or pneumatic pressure source. Monitor with an accurate pressure measuring standard. Slowly increase or decrease the pressure to accurately capture the precise moment that the switch changes state. To assure the most accurate and repeatable results, the switch must be tested in an identical manner each time the calibration is checked.

Increasing Set Points

If the normal operating pressure is below the set point, then the pressure should be increased from 0 PSI up to the increasing set point and then back down to the reset point. Repeat this cycle as necessary.

Decreasing Set Points

If the normal operating pressure is above the set point, then the calibration should be checked by first pressurizing to the normal operating pressure, then reducing the pressure to the decreasing set point, and then increasing the pressure to the reset point. Repeat this cycle as necessary.

To adjust pressure at which switch will operate, remove cover and tighten the hex head adjusting nut with a 3/4" wrench to increase pressure; loosen to reduce pressure.

After calibration is complete, reinstall the cover with new gaskets as required by the Maintenance instructions.



The switching element has been positioned with a dial indicator to a tolerance of ± 0.002 inches. Do not move this switching element! Its position has nothing to do with the set point adjustment. Any movement can either render the switch inoperative or cause the switching element to be damaged with overpressure.



Do not apply more than 300 psi positive differential to the switch. Do not apply a negative differential of more than 10 psi.

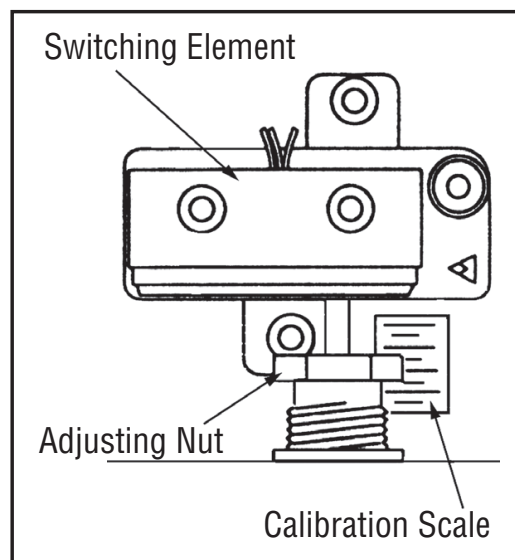

Maintenance

Replace cover gasket whenever cover is removed or minimum of once every 5 years, whichever comes first.

To replace cover gasket:

Remove the four cover screws. Remove old gasket. Place new gasket between housing and cover (or cover insulation). Line up holes in cover, gasket and housing. Insert the 4 screws and torque each to 7 to 10 in-lbs. (0.8-1.1 N-m).

For units shipped prior to 2019, order one of the following:

- Std. cover gasket, SOR P/N 8923-181, if no replacement kit was requested after issuance of notice of deviation (NRC Event #53856).
- Windowed cover gasket, SOR P/N 8923-903, if replacement kit was requested

For units shipped in 2019 or after, order SOR P/N 8923-181 as the replacement gasket.

