

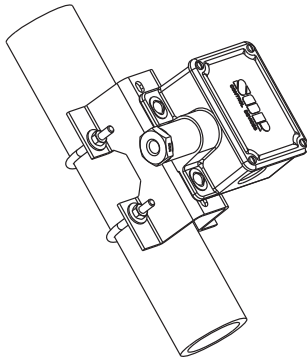

PK Pipe Kits

Part Numbers 5010-001, 5010-002,
5010-013, 5010-030

General Instructions



FOR SWITCH HOUSINGS PROVIDED
WITH MOUNTING HUBS

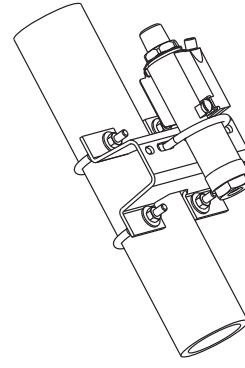
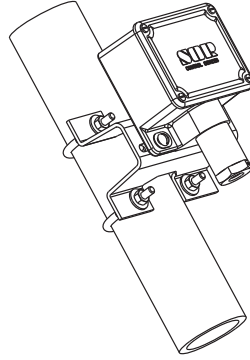

FOR MINI HERMET SWITCHES
AND 805PT TRANSMITTERS

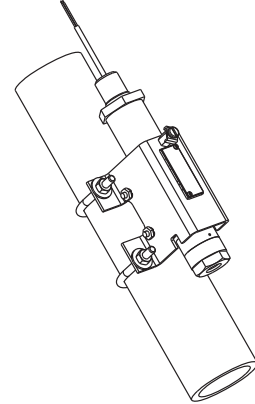

FOR MINI HERMET TRANSMITTERS

Part No. 5010-001 Pipe Kit

For detector housings provided with mounting hubs. Attach detector housing to pipe stanchion mounting bracket with hardware supplied as shown. Install bracket on pipe lengthwise or crosswise as desired with hardware provided.

Parts List

- (1) Universal pipe mounting bracket
- (2) 1/4-20 x 2 1/2" x 3 1/4" U-bolts with flat washers and hex nuts
- (2) 1/4-20 x 1" bolts with flat washers, lockwashers and hex nuts

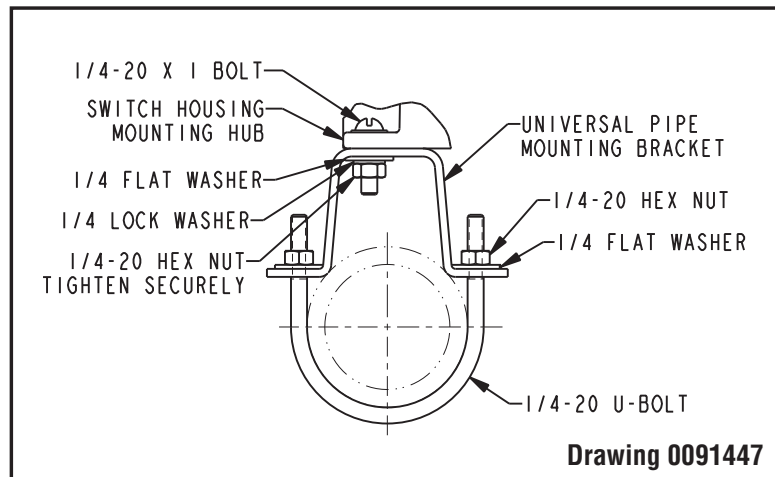

NOTE: If you suspect that a product is defective, contact the factory or the SOR® Representative in your area for a return authorization number (RMA). This product should only be installed by trained and competent personnel.

*Design and specifications are subject to change without notice.
For latest revision, go to www.sorinc.net*

Part No. 5010-013 Pipe Kit

For Series 102 Differential Pressure Detectors. Remove existing mounting bracket and screws. Attach switch body to pipe stanchion mounting bracket with hardware supplied, as shown. Install bracket on pipe lengthwise or crosswise as desired with hardware provided.

Parts List

- (1) Universal pipe mounting bracket
- (2) 1/4-20 x 2 1/2" x 3 1/4" U-bolts with flat washers and hex nuts
- (2) 1/4-20 x 1" bolts with flat washers

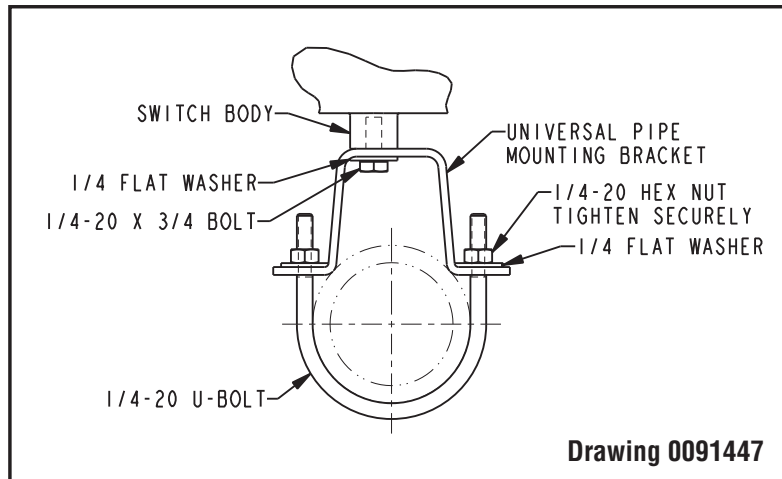

Part No. 5010-002 Pipe Kit

For Mini Hermet Series Detectors, Detector Housings without mounting hubs and 805PT Electronic Pressure Transmitters.

Attach detector to pipe stanchion mounting bracket with hardware supplied, as shown. Install bracket on pipe lengthwise or crosswise as desired with hardware provided.

Parts List

- (1) Universal pipe mounting bracket
- (2) 1/4-20 x 2 1/2" x 3 1/4" U-bolts with flat washers and hex nuts
- (1) 1/4-20 x 2" x 2 1/2" U-bolt with flat washers, lock washers and hex nuts

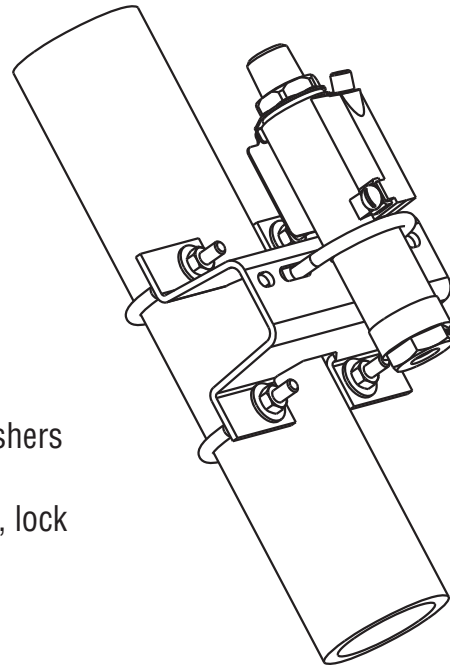

FOR MINI HERMET SWITCHES
AND 805PT TRANSMITTERS

Part No. 5010-030 Pipe Kit

For Mini Hermet Transmitters.

Remove ground screw and clamp. Attach transmitter to pipe stanchion mounting bracket with grounding post, as shown. Re-install ground screw and clamp to post. Install bracket spacers with hardware provided. Install bracket on pipe lengthwise or crosswise as desired with hardware provided.

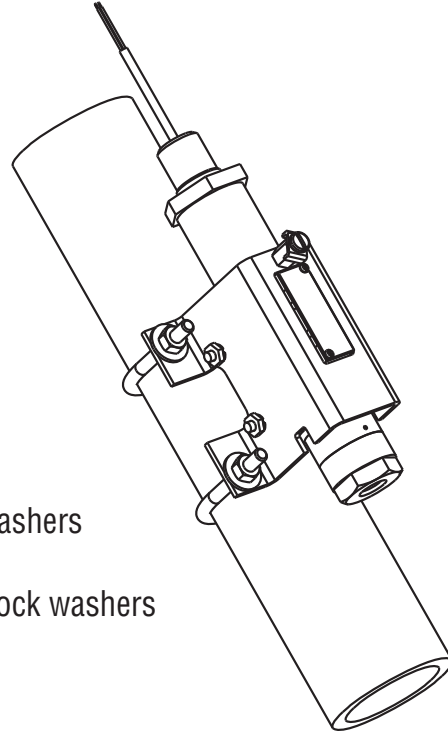

Parts List

- (1) Mini Hermet transmitter mounting bracket
- (2) 1/4-20 x 2 1/2" x 3 1/4" U-bolts with flat washers and hex nuts
- (2) 10-32 x 2" machine screws with spacers, lock washers and hex nuts
- (1) 10-32 hex grounding post

FOR MINI HERMET TRANSMITTERS



Printed in USA

sorinc.net

14685 West 105th Street, Lenexa, KS 66215 ■ 913-888-2630 ■ 800-676-6794 USA ■ Fax 913-888-0767

4/4 Registered Quality System to ISO 9001:2008

Form 435 (02.10) ©2010 SOR Inc.