



RF Two-Wire Level Control with Sensor Monitor

General Instructions

The RF Two-Wire Level Control produces a 7.5 mA (± 1.5 mA) or 14.5 mA (± 2 mA) current to indicate liquid presence/absence at the sensor. A sensor attached to the control acts as an antenna to transmit the process material level to the electronics.

The Failsafe Select detector determines the output of the unit when the process is touching the probe. A green LED on the control indicates 7.5 mA (± 1.5 mA) output. A yellow LED on the control indicates 14.5 mA (± 2 mA) output.

The RF Two-Wire level Control can be mounted with the sensor in the process (integral units K housing), or up to 150' (45m) from the sensor in the remote configuration (R housing).

The RF Two-Wire level Control constantly monitors sensor integrity. In the unlikely event of a sensor failure or remote electronic sensor module failure, the red LED is lit and indicates 25.5 mA (± 1.5 mA) output.

An optional timer (DT accessory) is available to delay the current change from 0 seconds to 10 minutes. The delay timer provides added process control, valuable for use in turbulent conditions. An optional adjustable differential circuit (AD accessory) allows the user to select on and off at different level points for the control.

DT and AD accessories may not be used on the same control unit.



Design and specifications are subject to change without notice.

For latest revision, go to www.sorfinc.net

NOTE: If you suspect that a product is defective, contact the factory or the SOR® Representative in your area for a return authorization number (RMA). This product should only be installed by trained and competent personnel.

Table of Contents

Pre-Installation Test	2
Installation	3
Remote Cable Connection	4
Electrical Connection	5
SOR RF Probe Grounding Scheme	6
Set Point and Sensor Monitor Calibration ..	7
Adjustable Differential Calibration	9
Delay Timer Operation	9
Sensor Replacement	10
Circuit Board Replacement	10
Troubleshooting	11
Dimensions	12-14

Pre-Installation I/O Test and Calibration

- 1 Remove instrument from shipping box and visually inspect for obvious physical damage. Report any shipping damage to the carrier. Report any internal discrepancies to the factory representative in your area. Record the serial number from the nameplate should conversation with the factory be necessary.
- 2 Remove housing cover.
- 3 Place instrument on an insulated surface or support so sensor does not touch a conductive surface.
- 4 Ensure area is safe and observe normal precautions for exposed and powered PC board.
- 5 Apply 12 - 24VDC loop power to + and - terminals, move failsafe select detector to LO position and observe the green LED. (See **J**).
- 6 Turn the LEVEL adjustment clockwise (up to 25 turns) to decrease the setpoint until the green LED turns off.

NOTE: Do not turn the LEVEL adjustment past 25 turns! Damage to the unit could result.

- 7 Turn the LEVEL adjustment one turn counterclockwise from the setpoint until the green LED lights. Next, slowly move a hand toward the probe to touch it. The green LED should stay on until the probe is touched. If the green LED turns off when the hand is near, turn the LEVEL adjustment counterclockwise so the LED remains lit until the hand touches the probe. Usually, 1-2 turns will locate the new setpoint.
- 8 When practical, use a small container of actual process material to calibrate the control. If the actual process vessel is metal, use a metal container (coffee can, etc.) and ground it to the instrument housing. If the actual process vessel is an insulator, such as, fiberglass, use a plastic container.

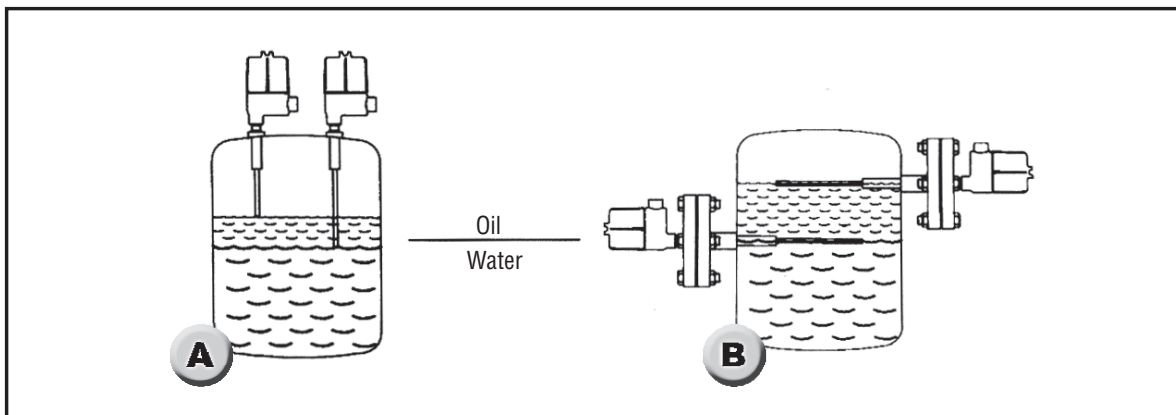

- ⑨ Immerse the sensor in the process material; the green LED should be off. If not, it may be necessary to decrease the setpoint.
- ⑩ To detect an interface, such as oil/water or foam/liquid, the lighter material must be on the sensor, then tuned out. Then adjust the setpoint to detect the heavier process \ material. (See **A** and **B**).
- ⑪ When the process material has a very low dielectric constant (such as mineral oil and butane) turn the level adjustment slowly to locate the setpoint, then 1/8 turn to 1/4 turns counterclockwise to precisely set.
- ⑫ When there is a DT in the accessory section of the model number, your level control is equipped with the optional delay timer. See page 9 for delay timer operation. The delay timer option may compensate for wave effects or turbulence and free fall time in solids.

Installation



This product must be installed with an explosion-proof breather vent per Agency requirements and the National Electric Code-Article 501, Section F, paragraph 3.

Standard Configuration is a 3/4 NPT(M) pipe nipple that threads into a 3/4" NPT(F) vessel nozzle or half coupling. Allow a 4-inch turn radius. (See **C** and **D**). Open tanks, vats, sumps or basins may require a locally made bracket mount similar to that shown in **G**.

Optional configuration is a raised face or flat face ANSI flange. See Form 1100 for selection. (See **E** and **F**).

Orientation. The control can be mounted in any position. Sensitivity is optimized when the greatest surface area of the sensor is parallel to the process level. (See **C** and **E**).

Placement and orientation of the sensor in a vessel is frequently determined by available nozzles. The sensor should be away from fill points to avoid false trips. The insulator bushing on the sensor should protrude a minimum of 1" from the inner wall of the vessel. The sensor must not touch any metal, nor should conductive process build-up be allowed to form a bridge between the sensor and a grounded metal tank wall.

If the sensor is a solid rod; it may be cut or bent for clearance or placement. Use a 3-inch radius should a bend be required. It is permissible to increase the sensor length by welding a length of identical rod to the supplied sensor. Recalibration is required if the probe length is changed.

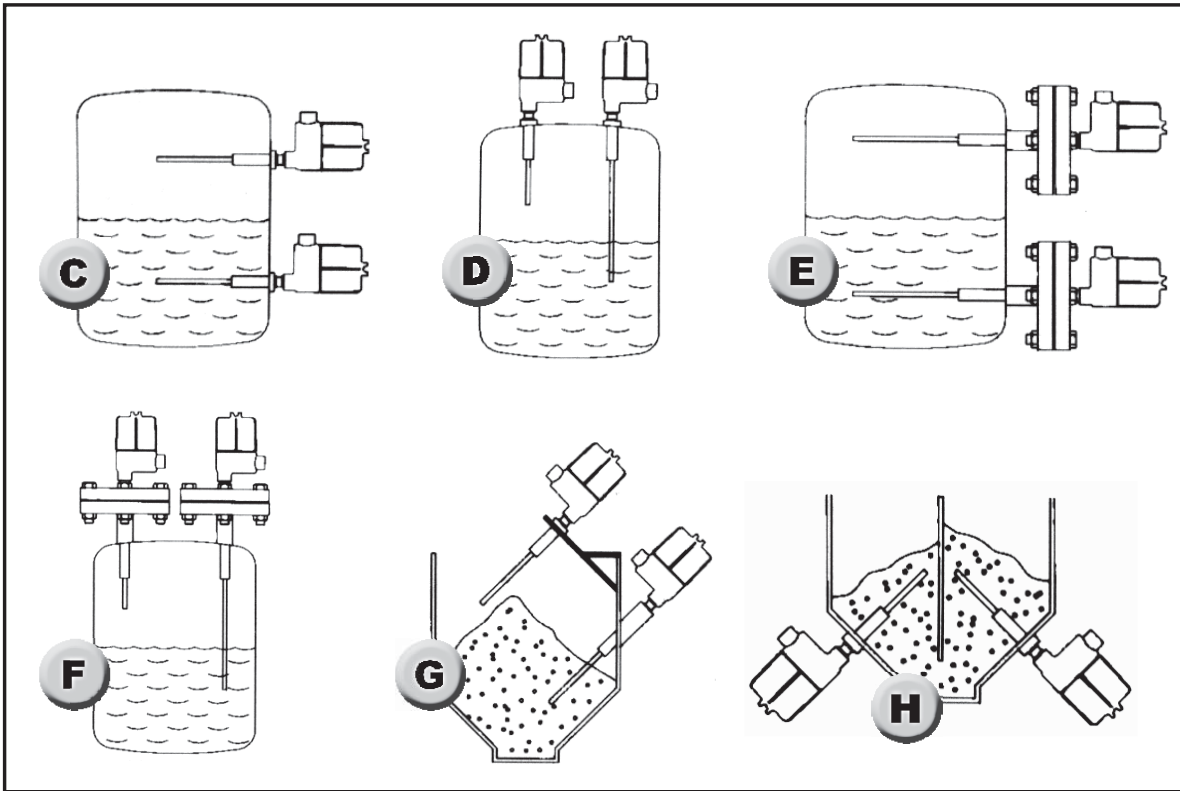

Remote Cable Connection

Conduit must be installed between the sensor base and the electronics housing to provide a raceway for sensor extension cables. (See **I**).



Electical power must be disconnected from explosion-proof models before the cover is removed. Failure to do so could result in severe personal injury or substatnial property damage.

Ensure that wiring conforms to all applicable local and national electrical codes and install unit(s) according to relevant national and local safety codes.

Fishing the Sensor Extension Cables

One three-conductor extension cable is required (SOR p/n 2924-113). Pull cable from the sensor base so that the free ends follow the fish through the conduit. (See **I**).

Connections Inside Sensor Base

Inside the sensor base, a remote circuit board rests in a plastic holder. Attach the cable wires to the terminal block on the circuit board as follows:

Terminal Block	Cable
+	red wire
-	black wire
PROBE	white wire

Connections Inside Electronics Housing

Inside the electronics housing, unscrew the bracket holding the circuit board in place. Pull the board out of the holder. At the bottom of the circuit board, there is a connector labeled "+ - probe". Attach the cable wires to the terminal block as shown above.

I

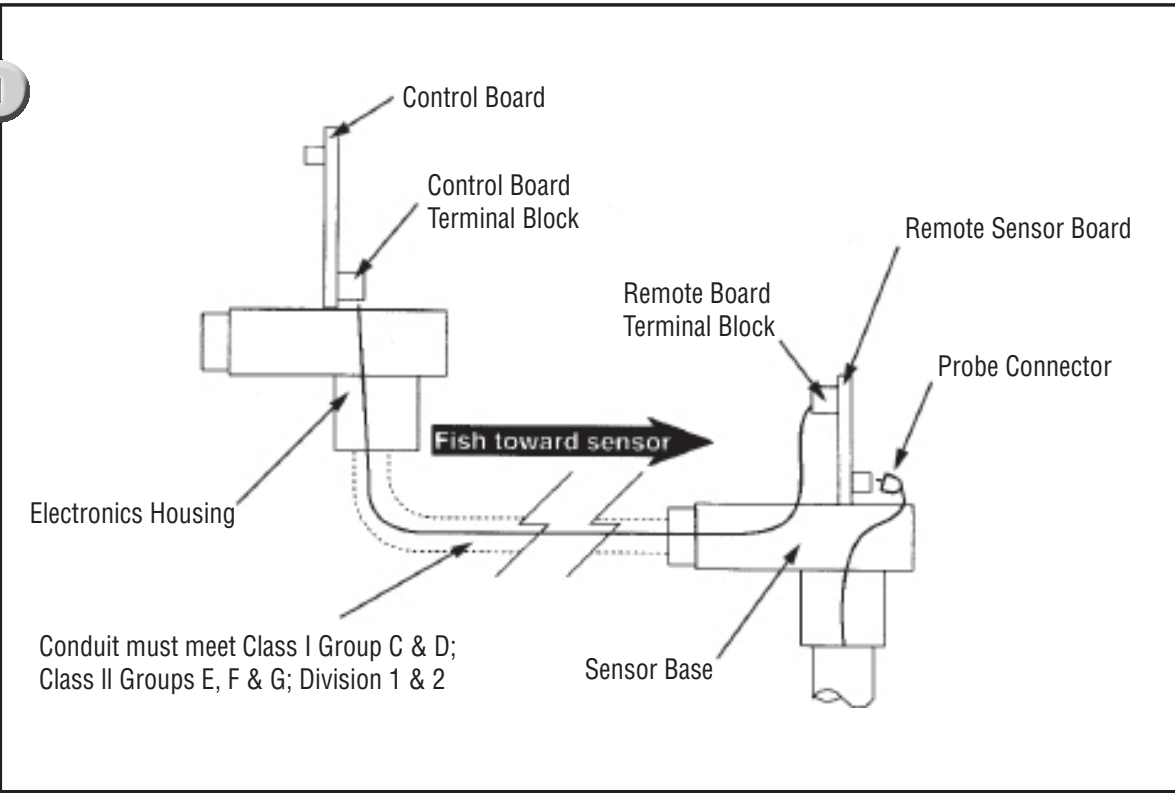

Electrical Connection

J

Use 22 AWG shielded three-conductor cable to make all signal and power connections.

Ensure that wiring conforms to all applicable local and national electrical codes and install unit(s) according to relevant national and local safety codes.

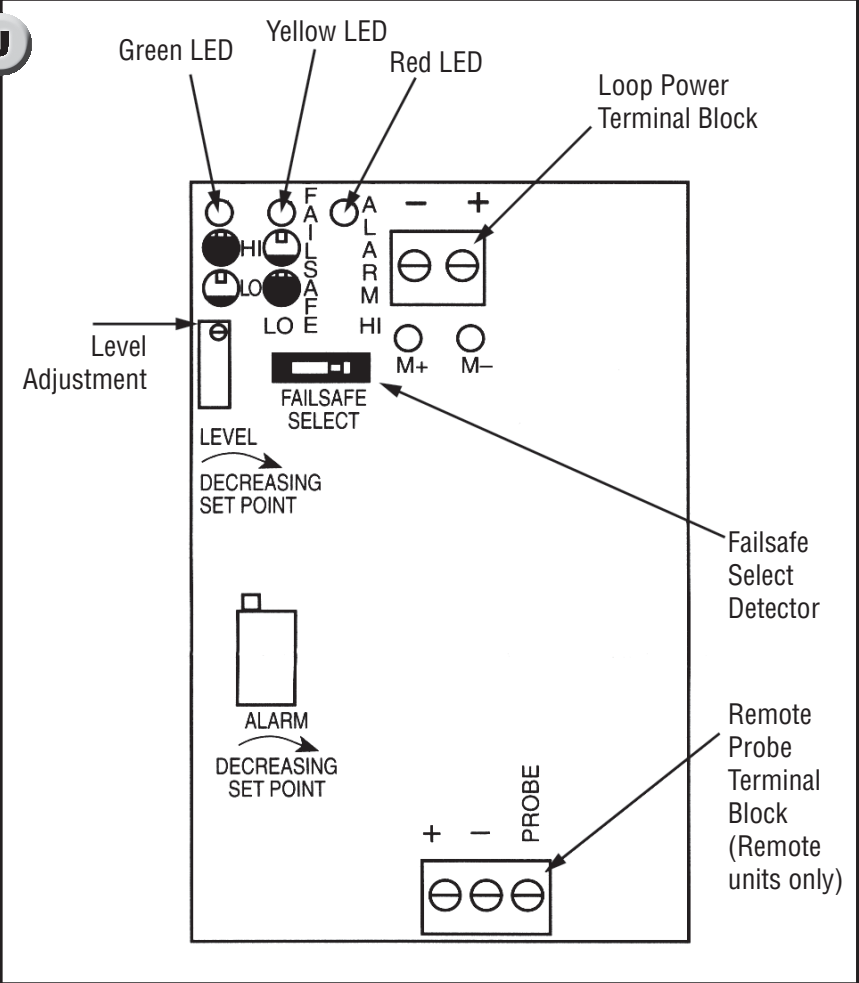

SOR RF Probe Grounding Scheme

Critical Grounding Path = ●-----●

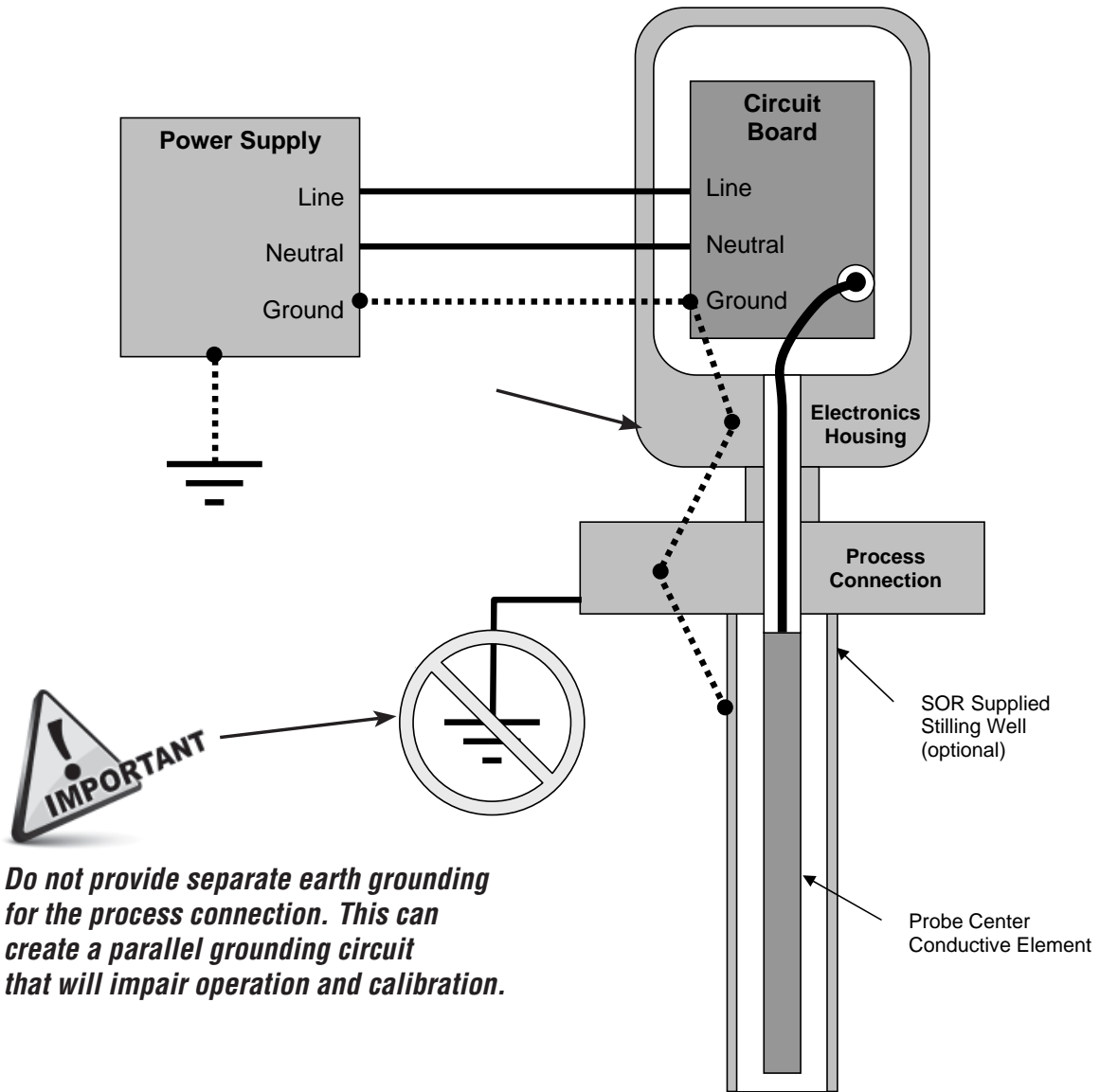

Do not provide separate earth grounding for the process connection. This can create a parallel grounding circuit that will impair operation and calibration.

Sensor Monitor and Set Point Calibration



Electrical power must be disconnected from explosion proof models before the cover is removed. Failure to do so could result in severe personal injury or substantial property damage.

- 1 Make sure the power source is turned off.
- 2 Remove the housing cover.
- 3 Pull power and signal wires through the conduit connection and into the control housing.
- 4 Locate Loop Power Terminal Block on the control board. (See **J**). Terminals are labeled “+” and “-”. Connect power leads to the proper terminals.
- 5 Do not exceed the maximum loop resistance for the circuit. (See **K**).

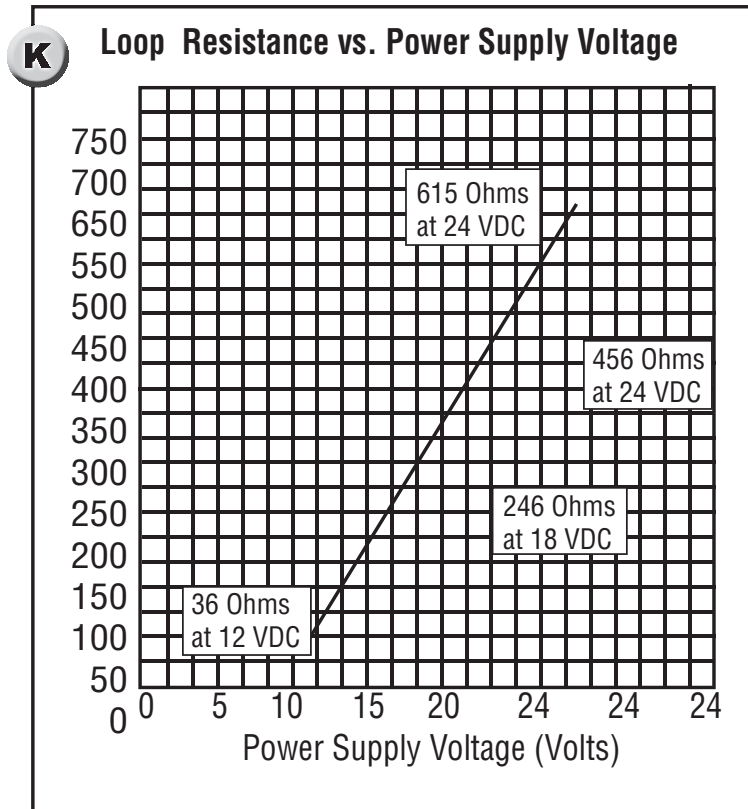

Units in Hazardous Locations – Prior to calibration, make sure that the work area is declassified before removing the explosion proof cover to calibrate the unit. Failure to do so could result in severe personal injury or substantial property damage.

Sensor Monitor Calibration (with probe disconnected)

- 1 Remove the housing cover.
- 2 Disconnect probe wire from the probe.
- 3 Turn ALARM adjustment counterclockwise until the red LED just lights. At this point, the loop current is stable at 25.5 mA \pm 1.5 mA.
- 4 Reconnect the probe wire to the probe. At this point, the loop current returns to 7.5 mA \pm 1.5 mA or 14.5 mA \pm 2 mA.

Sensor Monitor Calibration (with probe attached)

- 1 Remove the housing cover.
- 2 Verify there is no process material on the probe.
- 3 Turn ALARM adjustment counterclockwise until the red LED just lights. At this point, the loop current is stable at 25.5 mA \pm 1.5 mA. Turn the adjustment clockwise until the red LED turns off. Turn ALARM adjustment 1/2 turn further clockwise. At this point, the loop current is stable at 7.5 mA \pm 1.5 mA or 14.5 mA \pm 2 mA.

Current Output					
Green LED (7.5 mA)	Yellow LED (14.5 mA)	Red LED (25.5 mA)	Current Meter (+/-1.5A)	Sensor Status	Failsafe Detector Position
off	on	off	14.5 mA	Wet	LO
on	off	off	7.5 mA	Dry	LO
on	off	off	7.5 mA	Wet	HI
off	on	off	14.5 mA	Dry	HI
off	on	on	25/5 mA	Failure	LO/HI

Set Point Calibration

- 1 If the delay timer board is present (DT accessory), move all detectors to “off” position.
- 2 If the adjustable differential board is present (AD accessory), turn the adjustment fully clockwise.
- 3 Determine the desired FAILSAFE SELECT detector position for your application by using the Current Output Chart. (See **L**).

Failsafe LO Calibration

- 4 Move FAILSAFE SELECT detector on the control board to the LO position.
- 5 Move the process level to the point where detecting is needed.
- 6 Turn the LEVEL adjustment so that the yellow LED just lights and the green LED is off. At this point, the loop current is stable at 14.5 mA \pm 2 mA.
- 7 Lower the process level until the green LED lights, and the yellow LED is off. At this point, the loop current is stable at 7.5 mA \pm 1.5 mA.

Failsafe HI Calibration

- 4 Move FAILSAFE SELECT detector on the control board to the HI position.
- 5 Move the process level to the point where detecting is needed.
- 6 Turn the LEVEL adjustment so that the green LED lights, and the yellow LED is off. At this point, the loop current is stable at 7.5 mA \pm 1.5 mA.
- 7 Lower the process level until the yellow LED lights, and the green LED is off. At this point, the loop current is stable at 14.5 mA \pm 2 mA.

Adjustable Differential Set up

- ❶ Perform set point adjustment per previous instructions.
- ❷ Move the process level above the setpoint.
- ❸ Turn the adjustment on the AD (adjustable differential) circuit board fully counterclockwise.
- ❹ Move the process level to the point where the control will change state.
- ❺ Turn the adjustment on the AD circuit board clockwise carefully until green and yellow LED's exchange states.

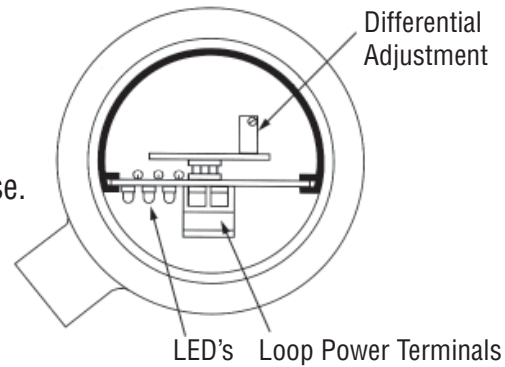

Delay Timer Operation (DT accessory)

The delay timer is present in units which contain a DT near the end of the model number. Time delays are available as shown in the Time Delay Detector Settings chart. Two sets of detectors located inside the electronics housing control the delay timer (see below).

On Delay = sensor dry → sensor wet
 Off Delay = sensor wet → sensor dry

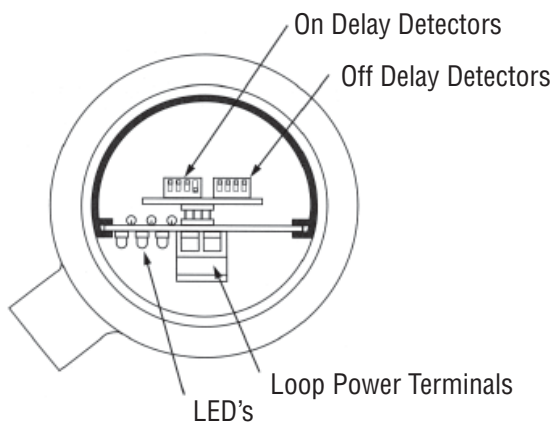

Time Delay Detector Setting				
Delay (Seconds)	Position 1	Position 2	Position 3	Position 4
0	OFF	OFF	OFF	OFF
1	OFF	OFF	ON	ON
2	OFF	OFF	OFF	ON
5	OFF	OFF	ON	OFF
10	ON	ON	ON	ON
15	OFF	ON	OFF	OFF
20	ON	OFF	OFF	ON
30	ON	OFF	OFF	OFF
45	OFF	ON	OFF	ON
60	OFF	ON	ON	OFF
90	ON	ON	OFF	OFF
120	OFF	ON	ON	ON
180	ON	OFF	ON	OFF
240	ON	OFF	ON	ON
300	ON	ON	OFF	ON
600	ON	ON	ON	OFF

- ❶ Remove the housing cover.
- ❷ Locate off and on delay detectors (above).
- ❸ Set the on and off delay timers by moving the detectors according to the Time Delay Detector Settings chart.

On Delay Detector set for 2 seconds (detector #4 is on, all other detectors are off)
Off Delay Detector set for 0 seconds (all detectors off)

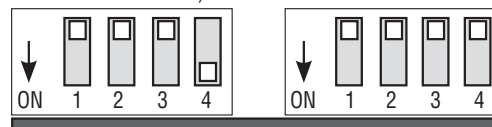

Sensor Replacement

- ① Disconnect power to the unit.
- ② Remove the housing cover.
- ③ Remove two screws holding bracket to plastic holder.
- ④ Slide out PC board to expose the sensor connection.
- ⑤ Disconnect the sensor wire.
- ⑥ Unscrew the sensor from the housing.
- ⑦ Apply thread sealant to the male threads of the new sensor.
- ⑧ Thread the new sensor into the bottom of the housing.
- ⑨ Connect the sensor wire to the “probe” connection on the circuit board.
- ⑩ Slide the PC board into the grooves in the plastic ring inside the housing.
- ⑪ Replace the two screws holding the bracket to the plastic holder. These screws are self-tapping. Do not over-tighten.
- ⑫ Reconnect power and replace the housing cover.

Replacement Sensors

See Form 1100 RF Catalog for replacement sensor model numbers

Circuit Board Replacement

- ① Disconnect power to the unit.
- ② Remove the housing cover.
- ③ Remove the two screws holding the bracket to the plastic holder.
- ④ Slide out PC board.
- ⑤ Disconnect power wiring, sensor wire, and the ground connection to the housing.
- ⑥ Connect the power wiring and sensor lead to the new board. Connect ground to the housing.
- ⑦ Slide the new board into the control housing.
- ⑧ Replace the two screws holding the bracket to the plastic holder. These screws are self-tapping. Do not over-tighten.
- ⑨ Reconnect power and replace the housing cover.

Troubleshooting

Sympton/Problem	Possible Cause	Corrective Action
No current in the loop No LED's lit	<ol style="list-style-type: none"> 1. Power supply turned off 2. Improperly wired terminal block 3. Broken power supply wire 	<ol style="list-style-type: none"> 1. Check power supply source 2. Check terminal block wiring 3. Check loop wire integrity
Current is greater than 27mA	<ol style="list-style-type: none"> 1. Incorrectly wired circuit 2. Circuit malfunction 	<ol style="list-style-type: none"> 1. Check current loop wiring 2. Replace the circuit board
<p>Current is 8mA when 16mA is expected</p> <p>or</p> <p>Current is 16mA when 8mA is expected</p>	<ol style="list-style-type: none"> 1. Failsafe Select detector is in the wrong position 2. Time Delay has not timed out (unit with DT accessory only) 3. Differential is applied (units with AD accessory only) 	<ol style="list-style-type: none"> 1. Set failsafe select detector to proper position 2. Check time delay detectors and wait for timeout or Set new timeout or cycle power (turn off power, then turn it back on) 3. Turn DIFFERENTIAL adjustment to get desired control
Current is not 8, 16, or 27mA or within tolerances	<ol style="list-style-type: none"> 1. Load exceeds maximum working load 	<ol style="list-style-type: none"> 1. Check the load and correct it per  page 7.

NOTE: Agency certified units, (FM, CSA, IEC) must be returned to SOR for repairs.

Dimensions

Dimensions are for reference only.
 Contact the factory
 for certified drawings
 for a particular model number.

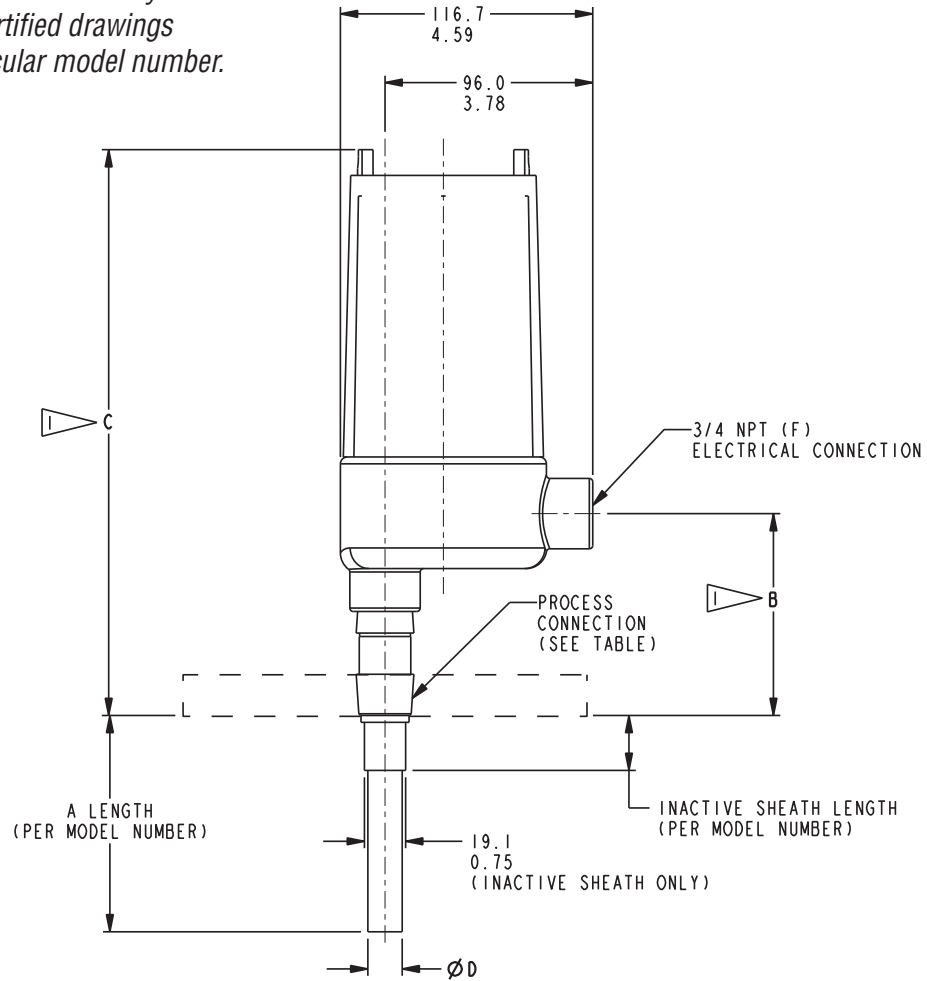

NOTES:
 1. THESE DIMENSIONS ARE BASED UPON
 A 5 THREAD ENGAGEMENT.

PROCESS CONNECTION	DIM B		DIM C	
	CABLE PROBE	ALL OTHER PROBES	CABLE PROBE	ALL OTHER PROBES
3/4 NPT (M)	87.8 3.46	94.1 3.71	256.0 10.08	262.4 10.33
1, 1-1/2, & 2 NPT (M)	99.7 3.92	97.3 3.83	268.0 10.55	265.6 10.46
FLANGED	158.5 6.24	158.5 6.24	326.8 12.87	326.8 12.87
STILLING WELL	N/A	120.0 4.72	N/A	288.3 11.35
SANITARY	N/A	94.1 3.71	N/A	262.4 10.33

SENSOR STYLE	ØD
BARE	12.7 0.50
SHEATH	15.9 0.63
BARE WITH STILLING WELL	26.7 1.05
SHEATH WITH STILLING WELL	26.7 1.05
CABLE	7.90 0.31
INACTIVE SHEATH	15.9 0.63
SANITARY	15.9 0.63

Linear = mm/inches

Drawing 0390654

Dimensions

Dimensions are for reference only. Contact the factory for certified drawings for a particular model number.

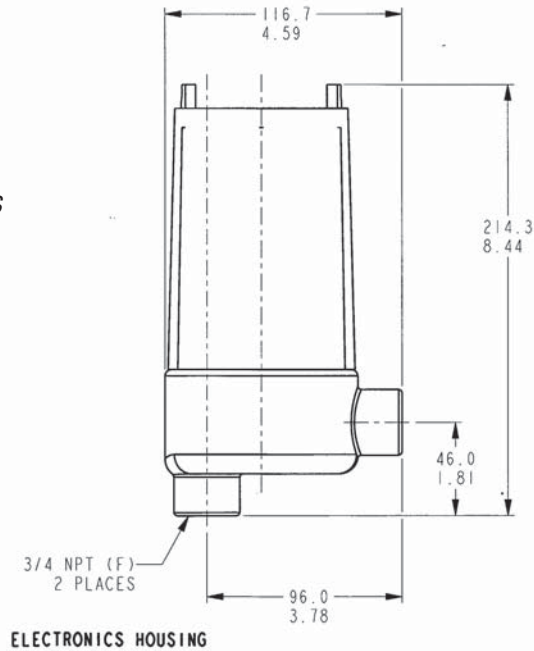

NOTES:
 I. THESE DIMENSIONS ARE BASED UPON A 5 THREAD ENGAGEMENT.

SENSOR STYLE	DIM D
BARE	12.7 0.50
SHEATH	15.9 0.63
BARE WITH STILLING WELL	26.7 1.05
SHEATH WITH STILLING WELL	26.7 1.05
CABLE	7.9 0.31
INACTIVE SHEATH	15.9 0.63
SANITARY	15.9 0.63

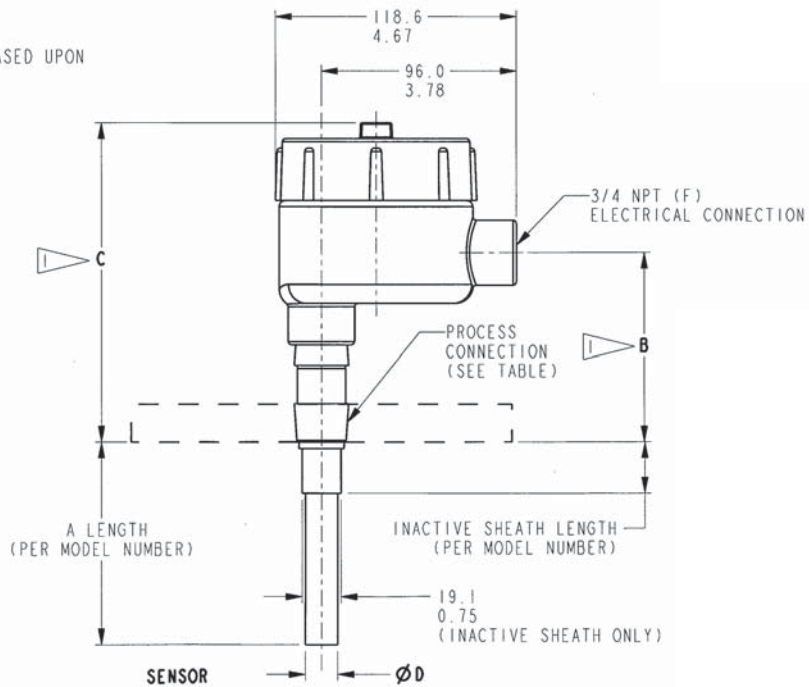

PROCESS CONNECTION	DIM B		DIM C	
	CABLE	ALL OTHER	CABLE	ALL OTHER
3/4 NPT (M)	87.8 3.46	94.1 3.71	152.9 6.02	159.2 6.27
1, 1-1/2, & 2 NPT (M)	99.7 3.92	97.3 3.83	164.8 6.49	162.4 6.39
FLANGED	158.5 6.24	158.5 6.24	223.7 8.81	223.7 8.81
STILLING WELL	N/A	120.0 4.72	N/A	185.1 7.29
SANITARY	N/A	94.1 3.71	N/A	159.2 6.27

Linear = mm/inches

Drawing 0390653

Dimensions

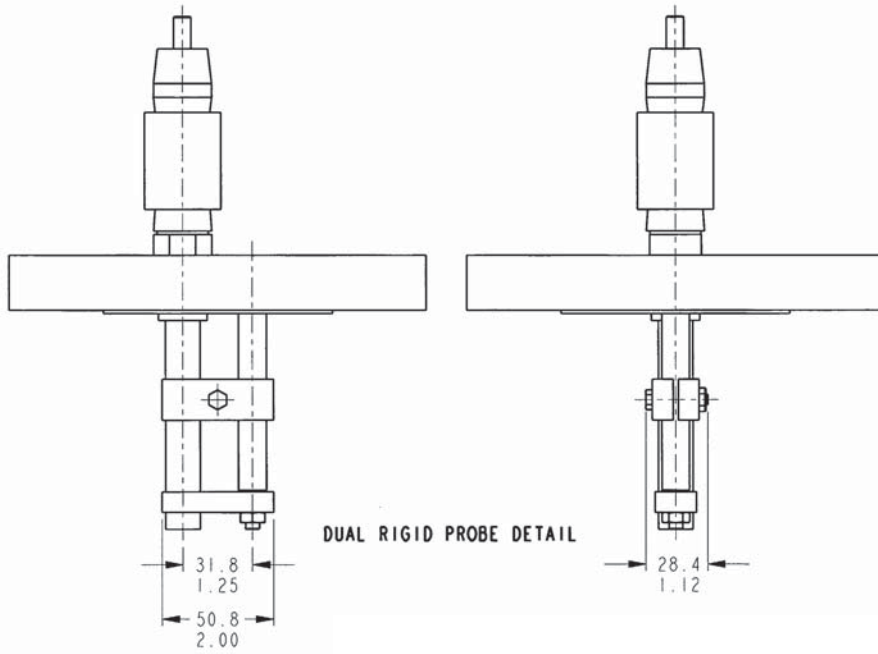

Dimensions are for reference only. Contact the factory for certified drawings for a particular model number.

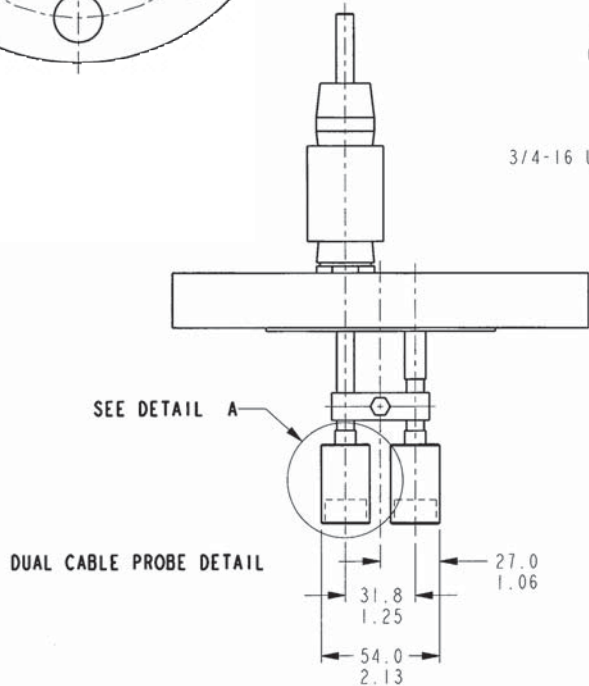
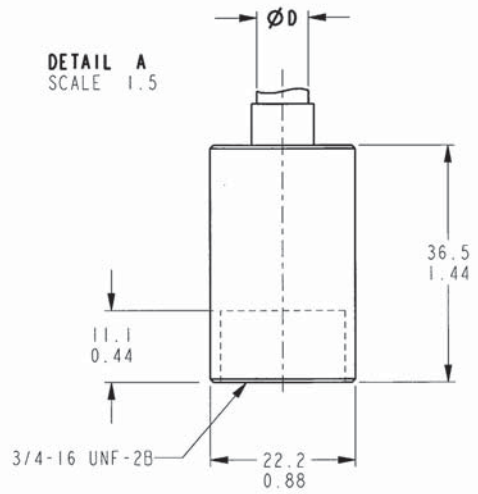
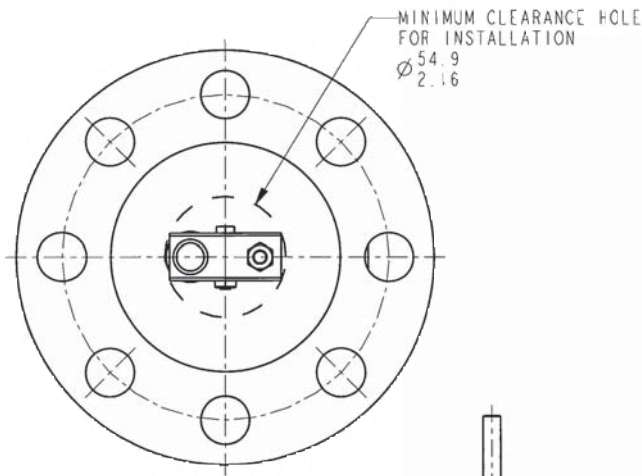

SENSOR STYLE	DIM D
BARE	12.7 0.50
SHEATH	15.9 0.63
BARE WITH STILLING WELL	26.7 1.05
SHEATH WITH STILLING WELL	26.7 1.05
CABLE	7.9 0.31
INACTIVE SHEATH	15.9 0.63
SANITARY	15.9 0.63

Linear = mm/inches
Drawing 0390653



Printed in USA

www.sorinc.net

14685 West 105th Street, Lenexa, KS 66215 ■ 913-888-2630 ■ 800-676-6794 USA ■ Fax 913-888-0767

16/16 Registered Quality System to ISO 9001:2008

Form 925 (09.11) ©2011 SOR Inc.