



# Temperature Sensors

Smart Sensors (SSI) manufactures a complete line of thermocouple elements, Resistance Temperature Detector (RTD) sensors, thermowells, industrial assemblies and specialty temperature sensors at our Lenexa, Kansas and Houston, Texas facilities. Products include multipoint temperature sensors, sanitary RTDs, high temperature furnace thermocouples, surface/tubeskin thermocouples and so much more to suit a wide variety of industrial applications and OEM markets.

With broad industry experience, technical expertise, and state-of-the-art facilities, we can meet both demanding and general purpose temperature measurement requirements.



# Table of Contents

---

## TEMPERATURE ELEMENTS ONLY

### RTDs (Resistance Temperature Detectors)

Industrial Style with Spring .....	3
Model 1150 with Plug .....	4
Model 1250 with Leads .....	5
Field Adjustable - cut to length.....	6

### Thermocouples

Industrial Style with Spring .....	7
Model 1100 with Plug .....	8
Model 1200 with Leads .....	9
Field Adjustable - cut to length and Unprotected .....	6

## ASSEMBLIES

RTDs and Thermocouples with heads, Thermowells, Transmitters and other options.

Remote Mounted - Model 1340.....	10
General Purpose -1400 Series with NPT process/instrument connections .....	11
Pipe Thermowell Assemblies .....	12
Pipe Thermowells Options .....	13
Thermowell Assemblies .....	14
Thermowells	
Threaded and Flanged.....	15
Socket and Van Stone .....	16
Sanitary and Weld In .....	17
Sample Probes.....	18
Thermowell and Sample Probe Options .....	20
High Temperature with Unprotected Thermocouple and Protection Tubes .....	21
Options and Accessories	
Sensor and Transmitter Options.....	22
Connection Heads .....	24
Terminal Blocks and Extensions.....	26
Sensor Connectors & Accessories .....	27
Thermocouple Extension Wire .....	29
In-Head Temperature Transmitters .....	30
In-Head Displays .....	33
Bimetal Thermometers .....	35
Surface	
Electric Trace - Model 1500 & 1500R.....	36
Pipe Clamp - Model 1550 .....	37
Washer Thermocouple - Model 1310 .....	37
Tubeskin Thermocouple - Model 1510 & 1520.....	38
Oil Seal - Model 1312 & 1314.....	39
Smart Sanitary Temperature Sensors.....	40
Heavy Duty Industrial Magnet - Model 1280 & 1290.....	42
Multipoint - Model 2020, 2030 & 2040.....	43

## SPECIALTY SENSORS

*Design and specifications are subject to change without notice.*

All RTDs are 100% tested to ensure that the functionality of the product has not been affected by the manufacturing process. The standard sheath material on all RTDs specified in this section is 316SS. Other sheath materials and coatings are available. Elements are either thin film or wire wound, depending on the style RTD selected. Thin film elements are used in all constructions unless otherwise specified. Each RTD is supplied with a heavy duty spring.

### STANDARD RTD SPECIFICATIONS

**Element Material:** Platinum

**Element Type:** 100 ohms @ 0°C,  
0.00385 DIN Curve

**RTD Type:** Three wire  
(Color code: red, red, white)

**Wire Gauge:** 22 Gauge

### ACCURACY TOLERANCES

for platinum resistance elements are defined by DIN EN 60751 (ITS 90) as follows:

**Class B:**  $\Delta t = \pm (0.3 + 0.005 |t|)$

**Class A:**  $\Delta t = \pm (0.15 + 0.002 |t|)$

**1700:**  $\Delta t = \pm 0.1(0.3 + 0.005 |t|)$

**A+:**  $\Delta t = \pm 0.1(0.3 + 0.005 |t|)$

Class	Temperature Range	
	°C	°F
Class B	-70° to +500°	-94° to +932°
Class A	-50° to +300°	-58° to +572°
1700	0° to +150°	+32° to +302°
A+	0° to +100°	32° to 212°

### DESIGN TYPE CODES

**PO** This design uses nickel clad copper lead wire insulated with Teflon®. Maximum upper temperature rating of 500°F (260°C).

**PH** Our high temperature version can be used up to 900°F (482°C), and uses fiberglass leads.

**PM** Heavy duty applications is where this style should be specified. It is suited for temperatures up to 900°F (482°C). Mineral insulated cable is used for this type of RTD. Can be used in cryogenic applications at temperatures down to minus 200°F (-129°C).

**RN** 120 Ohm nickel @ 0°C (Edison #7) Color code: red, red, black. (DIN 43760)

**1700** Higher accuracy (available in 1/4" Single 4 wire & Dual 4 wire only). Maximum temperature rating of 302°F (150°C).

Select a designator for each component. There is a dash between each designator including options, i.e. PO-14-S-10-R-TW-GA. If not required leave blank.

SENSOR TYPE	OD	ELEMENTS	LENGTH <sup>1</sup>	MATERIAL	OPTIONS
<b>PO</b>	<b>14</b>	<b>S</b>	<b>10</b>	<b>R</b>	<b>GA</b>
PO	18 = 1/8" (3.2 mm)	S = Single	(Inches)	R = 316SS	TW = 2 Wire
PH	316 = 3/16" (4.8 mm)	D = Dual		D = 321SS	FW = 4 Wire
PM	14 = 1/4" (6.4 mm)			A = Alloy 600	GA = Class A
RN	38 = 3/8" (9.5 mm)				GAA* = A+ Design
1700	14 = 1/4" only (6.4mm)				HV = High Vibration (PM)
					CR = Cryogenic (PM)

#### Notes

<sup>1</sup> Length is determined by assembly when used in well or protection tube.

To determine the length for replacement RTD's use the following formula:  
U Length of well + T Length + A Length + 0.50" = Sensor Length

\*Highest accuracy (available in 1/4" Single 4 wire & Dual 4 wire only). Maximum temperature rating of 212°F (100°C). Temperature accuracy is guaranteed to be within 0.25 degrees over the temperature range.

See page 12-16 for description of U, T & A lengths depending on type of well.

### WIRE CONFIGURATIONS

Three Wire (Standard)

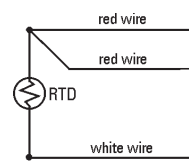

Four Wire

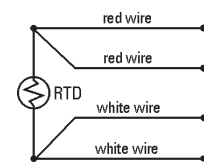

### DESIGN TYPES

The design types provide environmental and accuracy solutions to virtually any process RTD application. Accuracy options offer the user more choices for tighter process control. Class B accuracy has long been the work horse of the industrial RTD temperature loop and is a good fit for most process needs. Slightly better than Class B is Class A accuracy which has long filled the void for the most demanding accuracy needs. The 1700 Smart Sensors have surpassed the Class A specifications for those applications where process accuracy must be measured in hundredth's of a degree. Optional NIST certification for 1700 products can be supplied and the accuracy statement is the finished product profile not just the accuracy of the element. The stability and accuracy of this product may eliminate costly and cumbersome sensor matching.

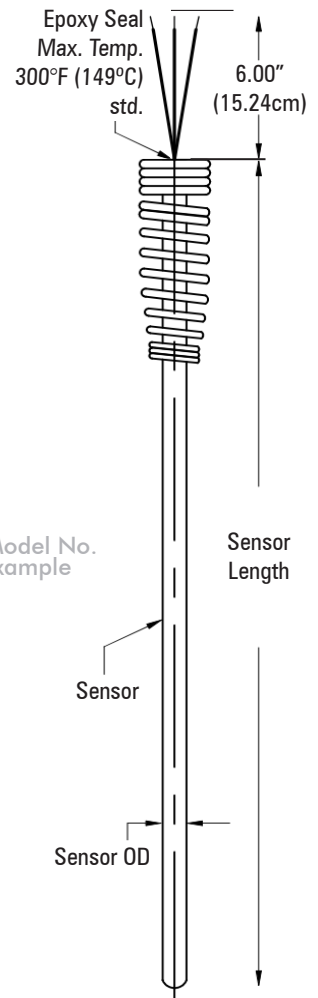

# Temperature Sensors

## Model 1150 with Plug - RTDs

Select a designator for each component. There is a dash between each designator including options, i.e. 1150-RP-18-L-10-R-12-BA-GA. If not required leave blank.

SENSOR						TERMINATION	OPTIONS
<b>1150</b>	<b>RP</b>	<b>18</b>	<b>L</b>	<b>10</b>	<b>R</b>	<b>12</b>	<b>BA-GA</b>
Model	Sensor Type	OD	Construction	Sheath Length (inches)	Sheath Material		

Model No. Example

SENSOR	
<b>SENSOR TYPE</b>	
RP	100 ohm Platinum Temperature Coefficient .00385 ohms/ohm/°C
RN	120 ohm Nickel (Edison #7) Temperature Coefficient 0.00672 ohms/ohm/°C
Other temperature coefficients and ohm values available.	
Note: Three-wire is standard. Class B is standard. Tolerance per DIN Standard 60751	
<b>OD</b>	
18	1/8" (3.2 mm)
316	3/16" (4.8 mm)
14	1/4" (6.4 mm)
38	3/8" (9.5 mm)
<b>CONSTRUCTION</b>	
L	Low Temp up to 500°F (260°C)
H	High Temp up to 900°F (482°C)
M	Mineral Insulated to 900°F (482°C)
DL	Dual Low Temp up to 500°F (260°C)
DH	Dual High Temp up to 900°F (482°C)
DM	Dual Mineral Insulated to 900°F (482°C)
<b>SHEATH MATERIAL</b>	
R	316SS

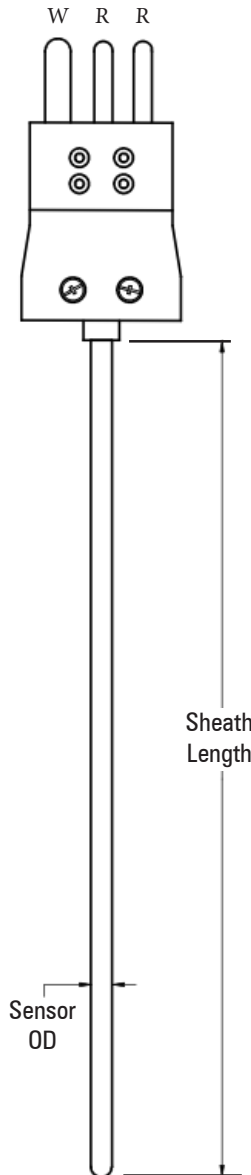

TERMINATION	
1	Bare Ends - 1" (2.54 cm) std. For longer leads, see Type 1250
11	Spade Lugs
12	Large Three Pin Plug
13	Large Three Pin Jack
14	Mini Three Pin Plug
15	Mini Three Pin Jack

See page 27-28 for more details.

OPTIONS	
BA	Bayonet Adapter (Adjustable) 1/8" (3.2 mm) OD only*
BF	Bayonet Cap & Spring, 1/8" (3.2 mm) and 3/16" (4.8 mm) OD only Note: inches from cap to tip (fixed)
BD45	45° Bend in Sheath Note: inches from bend to tip
BD90	90° Bend in Sheath Note: inches from bend to tip
BR18	Adj Brass Comp Fitting 1/8" NPT**
BR14	Adj Brass Comp Fitting 1/4" NPT**
BR12	Adj Brass Comp Fitting 1/2" NPT**
CR	Cryogenic (M Construction)
CV	Connector with Epoxy Sealed Screws
FW	Four-Wire (without connector)
GA	Class A
HV	High Vibration (M Construction)
LB	Connector "L" Bracket
SS18	Adj SS Comp Fitting 1/8" NPT*
SS14	Adj SS Comp Fitting 1/4" NPT*
SS12	Adj SS Comp Fitting 1/2" NPT*
TF	Teflon® Coated Sheath
VH	Vent Hole in Compression Fitting

\*Not available with 38 OD option

\*\*Add T after SS or BR for Teflon® Ferrule

See page 22-23 for more options.

# Temperature Sensors

## Model 1250 with Leads - RTDs

Select a designator for each component. There is a dash between each designator including options, i.e. 1250-RP-316-L-10-R-10-MF-12-BA-GA. If not required leave blank.

SENSOR								TERMINATION	OPTIONS
<b>1250</b>	<b>RP</b>	<b>316</b>	<b>L</b>	<b>10</b>	<b>R</b>	<b>10</b>	<b>MF</b>	<b>12</b>	<b>BA-GA</b>
Model	Sensor Type	OD	Construction	Sheath Length (inches)	Sheath Material R - 316SS <small>Other sheaths available</small>	Lead Length (inches)	Lead Insulation		

Model No. Example

### SENSOR

#### SENSOR TYPE

RP 100 ohm Platinum Temperature Coefficient 0.00385 ohms/ohm/°C

RN 120 ohm Nickel (Edison #7) Temperature Coefficient 0.00672ohms/ohm/°C

Other temperature coefficients and ohm values available.

Note: Three-wire, Class B RTD is standard. Tolerance per DIN Standard 60751. Leadwire is nickel clad copper multistrand.

Color code: Platinum - Red/Red/White  
Nickel - Red/Red/Black

#### OD

18 1/8" (3.2 mm)  
316 3/16" (4.8 mm)  
14 1/4" (6.4 mm)  
38 3/8" (9.5 mm)

#### CONSTRUCTION

L Low Temp up to 500°F (260°C)  
H High Temp up to 900°F (482°C)  
M Mineral Insulated to 900°F (482°C)  
DL Dual Low Temp up to 500°F (260°C)  
DH Dual High Temp up to 900°F (482°C)  
DM Dual Mineral Insulated to 900°F (482°C)

#### SHEATH MATERIAL

R 316SS

See page 20 for additional materials.

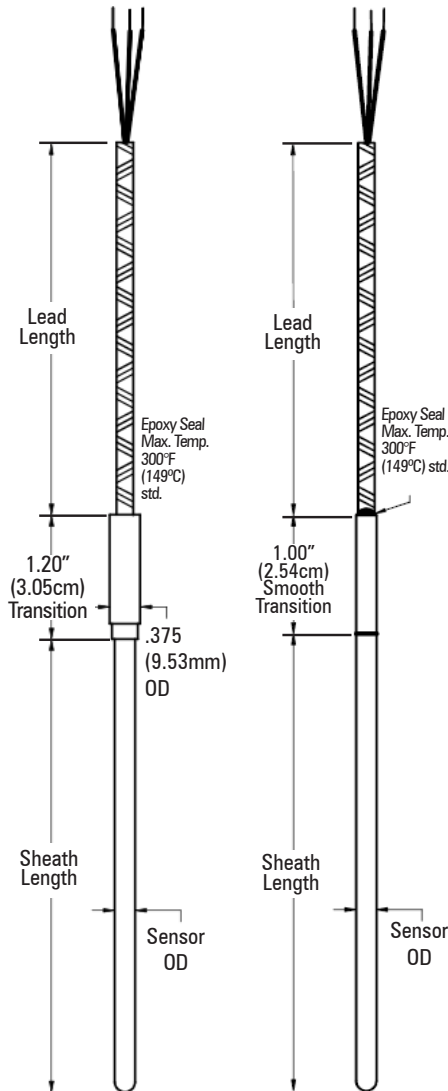

### LEAD INSULATION

M F Multi Strand (flexible) Fiberglass 22 gauge (use with high temperature)

M T Multi Strand (flexible) Teflon® 22 gauge (use with low temperature)

Note: 1/8" (3.2 mm) OD - 24 gauge

### TERMINATION

1	Bare Ends	
		2 1/2" (6.35 cm) std.
11	Spade Lugs	
12	Large Three Pin Plug	
13	Large Three Pin Jack	
14	Mini Three Pin Plug	
15	Mini Three Pin Jack	

See page 27-28 for more details.

### OPTIONS

A Armor (Stainless Steel)  
AP Armor with PVC Jacket  
AT Armor with Teflon® Jacket  
BA Bayonet Adapter (Adjustable) 1/8" (3.2 mm) OD only  
BF Bayonet Cap & Spring, 1/8" (3.2 mm) and 3/16" (4.8 mm) OD only  
Note: inches from cap to tip (fixed)  
BD45 45° Bend in Sheath Note: inches from bend to tip  
BD90 90° Bend in Sheath Note: inches from bend to tip  
BR18 Adj Brass Comp Fitting 1/8" NPT\*  
BR14 Adj Brass Comp Fitting 1/4" NPT\*

BR12 Adj Brass Comp Fitting 1/2" NPT\*  
BS Bell Spring Transition Relief  
CG12 Weather Tight Fitting 1/2" NPT  
CR Cryogenic (M Construction)  
CV Connector with Epoxy Sealed Screws  
DE12 Double Ended Hex Fitting, 1/2" NPT Spring Loaded  
FW Four-Wire (without connector)  
GA Class A  
HTP High Temperature Potting Service over 400°F (204°C)  
HV High Vibration (M Construction)  
LB Connector "L" Bracket  
NT No Transition, (Sheath length is over all length)

SB Stainless Steel Overbraid Leads  
SS18 Adj SS Comp Fitting 1/8" NPT\*  
SS14 Adj SS Comp Fitting 1/4" NPT\*  
SS12 Adj SS Comp Fitting 1/2" NPT\*  
ST Smooth Transition, 3/16" (4.8 mm) OD and larger  
TA Tube on Armor, 1/4" (6.35 mm) OD x 2" (50.8 mm) long  
TF Teflon® Coated Sheath  
VH Vent Hole in Compression Fitting  
WC Wire Clamp Bracket for Leads  
WP Weld Pad, 1" (2.54 cm) x 1" (2.54 cm) x 1/8" (0.32 cm) SS

\*Add T after SS or BR for Teflon® Ferrule

See page 22-23 for more options.

## Field Adjustable Thermocouples and RTDs

Today's high inventory costs plus the need for quick turnaround on plant maintenance projects or the routine replacement of thermocouples and RTDs dictates the need for standardization.

Now you can standardize on one length sensor for all your temperature requirements. Our Model ATC, APO, and APH sensors are easily cut to length in the field to a minimum of 3 inches (7.62 cm) long. The removable grommet is easily reinserted into the sheath and protects the leads from abrasion and provides some mechanical relief. All adjustable sensors are also supplied with a heavy duty spring.



Field adjustable thermocouples and RTDs may be ordered as a "PAK" option. PAKs include a tube cutter, extra grommet, spring, and spade lugs.

### Thermocouple Specifications

**Wire Type:** Fiberglass insulated 20 gauge solid  
**Sheath:** 0.250" (6.4 mm) OD 316 stainless steel  
**Maximum Temperature:** 900°F (482°C)

Select a designator for each component. There is a dash between each designator including options, i.e. ATC-J-18-G-PAK. If not required leave blank.

Thermocouple				Options
ATC	J	18	G	PAK
Model	Sensor Type	Std. Lengths*	Junction	
J	Iron Constantan®	18" (45.7 cm)	G Grounded	PAK**
K	Chromel® Alumel®	24" (60.96 cm)	U Ungrounded	DEI2
T	Copper Constantan®	30" (76.2 cm)	DG Dual Grounded	See page 22-23 for more options.
E	Chromel® Constantan®	36" (91.44 cm)	DU Dual Ungrounded	

\* Other lengths available.

\*\*PAK option consists of a tube cutter, extra grommet and spade lugs.

### RTD Specifications

**Accuracy:** Per DIN EN 60751, Class B  
**Bulb Type:** 100 ohm Platinum 0.00385 DIN Curve  
**Wire Type:** Teflon® insulated 22 ga. multi-stranded APO;  
 Fiberglass insulated 22 ga. multi-stranded APH  
**Sheath:** 0.250" (6.4 mm) OD 316 stainless steel  
**Maximum Temperature:**  
 APO - up to 500°F (260°C); APH - up to 900°F (482°C)

Select a designator for each component. There is a dash between each designator including options, i.e. APO-18-S-PAK. If not required leave blank.

RTD			Options
APO	18	S	PAK
Type	Std. Lengths *	Elements	
APO	18" (45.7 cm)	S Single	PAK*
APH	24" (60.96 cm)	D Dual	DEI2
	30" (76.2 cm)		(Double-ended Spring Loaded 1/2" NPT)
	36" (91.44 cm)		See page 22-23 for more options.

## Unprotected Thermocouples

At times due to economic reasons, a non-mineral insulated cable thermocouple type is required. Unlike sheathed types these thermocouples are unprotected from oxidation or chemical attack. Consequently their life expectancy is considerably shorter than that of an MI cable design.

Select a designator for each component. There is a dash between each designator.

Thermocouple		
30	K	14
Model	Sensor Type	Length (inches)
30	K	14

### Example:

Unprotected thermocouple model no.: 30-K-14 = Single beaded Chromel® Alumel®, 8 gauge, 0.500" (12.7 mm) OD, 14" (35.56 cm) long.

Model	Diameters		Wire Gauge	Sensor Type
	Single	Dual		
10	0.150" (3.8 mm)		20	J, K, T, E
15		0.187" (4.8 mm)	20	J, K, T, E
20	0.250" (6.4 mm)		14	J, K, T, E
25		0.313" (7.9 mm)	14	J, K, T, E
30	0.500" (12.7 mm)		8	J, K, T, E
35		0.550" (13.9 mm)	8	J, K, T, E
40	0.153" (3.9 mm)		24	R & S
45		0.187" (5.0 mm)	24	R & S

### M.I. Cable Thermocouple Elements

All industrial thermocouples are manufactured using a high purity mineral oxide insulation and a metallic sheath. The standard sheath material unless otherwise noted is 316SS. The ODs found in this section are those that are typically used when an element is housed in a well or protection tube. Each industrial thermocouple is supplied with a heavy duty spring.

**Wire Gauge:** 20 gauge solid Teflon® insulated

For elements used in wells or protection tubes, indicate designator for each component. There is a dash between each designator.

**Example:** A replacement thermocouple with these specifications: Iron/Constantan®, 0.250" (6.4 mm) OD, grounded measuring junction, with a 316SS sheath, and 12" (30.48 cm) length would have the model number: J-14-G-R-12.

SENSOR TYPE <sup>1</sup>	OD <sup>2</sup>	JUNCTION	SHEATH <sup>3</sup>	LENGTH <sup>4</sup>
J	14	G	R	12
J = Iron Constantan®	18 = 1/8" (3.2 mm)	G = Grounded	P = 304SS	(Inches)
K = Chromel® Alumel®	316 = 3/16" (4.8 mm)	U = Ungrounded	R = 316SS	
T = Copper Constantan®	14 = 1/4" (6.4 mm)	E = Exposed	Q = 310SS	
E = Chromel® Constantan®	516 = 5/16" (7.9 mm)	DG = Dual Grounded	D = 321SS	
N = Nicrosil® Nisil®	38 = 3/8" (9.5 mm)	DU = Dual Ungrounded	F = 347SS	
		DE = Dual Exposed	A = Alloy 600	
			W = Alloy 601	
			I = Alloy 800	

### Notes

- For Special Limits repeat sensor type i.e. JJ.
- 1/8" (3.2 mm) OD thermocouple comes with a 1/4" (6.4 mm) OD 2" (5.08 cm) long stainless steel transition. (See drawing above.)
- Other Sheath Materials available - consult factory.
- Length determined by assembly when used in a well. For replacement thermocouples use the following formula:  
 $U \text{ Length of well} + T \text{ Length} + A \text{ Length} + 0.50" = \text{Sensor Length}$  (See page 12-17 for description of U, T & A lengths.)

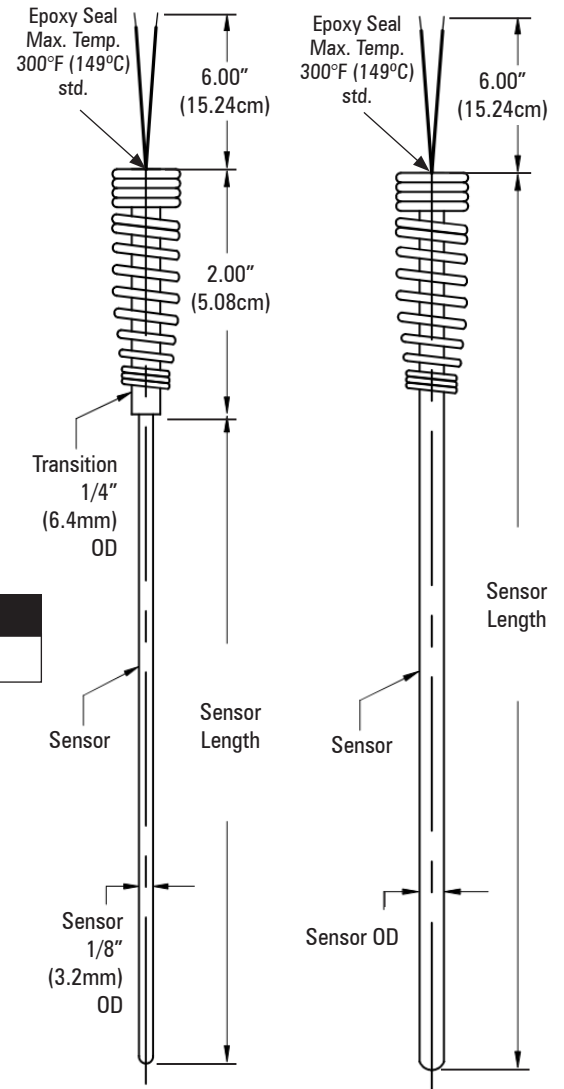

# Temperature Sensors

## Model 1100 with Plug - Thermocouples

Select a designator for each component. There is a dash between each designator including options, i.e. 1100-J-14-G-10-L-BA-LB. If not required leave blank.

SENSOR						TERMINATION	OPTIONS
<b>1100</b>	<b>J</b>	<b>14</b>	<b>G</b>	<b>10</b>	<b>L</b>	<b>12</b>	<b>BA-LB</b>
Model	Sensor Type	OD	Junction	Sheath Length (inches)	Sheath Material		

Model No.  
Example

SENSOR	
<b>SENSOR TYPE</b>	
J	Iron Constantan®
K	Chromel® Alumel®
T	Copper Constantan®
E	Chromel® Constantan®
N	Nicrosil® Nisil®
R	Platinum 13% Rhodium
	Pure Platinum
S	Platinum 10% Rhodium
	Pure Platinum
<b>OD</b>	
125	1/25" (1.0 mm)
116	1/16" (1.6 mm)
18	1/8" (3.2 mm)
316	3/16" (4.8 mm)
14	1/4" (6.4 mm)
516	5/16" (7.9 mm)
38	3/8" (9.5 mm)
<b>JUNCTION</b>	
G	Grounded
U	Ungrounded
E	Exposed
DG	Dual Grounded
DU	Dual Ungrounded
DE	Dual Exposed
<b>SHEATH MATERIAL</b>	
P	304SS
R	316SS
Q	310SS
A	Alloy 600
Standard Sheath Material is 316SS.	
Other sheaths available.	

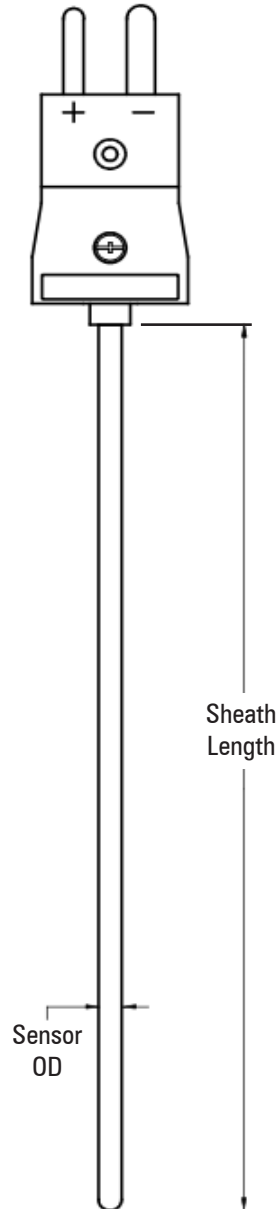

TERMINATION	
1	Bare Ends - 1" (2.54 cm) std. <i>For longer leads, see Type 1200</i>
2	Large Plug
3	Miniature Plug
4	Hi Temp Large Plug
5	Large Jack
6	Miniature Jack
7	Hi Temp Large Jack
8	Dual Large Plug*
9	Dual Large Jack*
10	Terminal Head
11	Compensated Spade Lugs
12	Three Pin Plug
13	Three Pin Jack

\* Two single connectors are bracketed for MI cable termination.  
*See page 27-28 for more details.*

OPTIONS	
BA	Bayonet Adapter (Adjustable) 1/8" (3.2 mm) OD only
BF	Bayonet Cap & Spring, 1/8" (3.2 mm) and 3/16" (4.8 mm) OD only <i>Note: inches from cap to tip (fixed)</i>
BD45	45° Bend in Sheath <i>Note: inches from bend to tip</i>
BD90	90° Bend in Sheath <i>Note: inches from bend to tip</i>
BR18	Adj Brass Comp Fitting 1/8" NPT*
BR14	Adj Brass Comp Fitting 1/4" NPT*
BR12	Adj Brass Comp Fitting 1/2" NPT*
CV	Connector with Epoxy Sealed Screws
LB	Connector "L" Bracket
SS18	Adj SS Comp Fitting 1/8" NPT*
SS14	Adj SS Comp Fitting 1/4" NPT*
SS12	Adj SS Comp Fitting 1/2" NPT*
TF	Teflon® Coated Sheath
VH	Vent Hole in Compression Fitting
*Add T after SS or BR for Teflon® Ferrule	
<i>See page 22-23 for more options.</i>	



# Temperature Sensors

## Model 1200 with Leads - Thermocouples

Select a designator for each component. There is a dash between each designator including options, i.e. 1200-J-14-G-10-P-10-F-3-BA-GA. If not required leave blank.

SENSOR								TERMINATION	OPTIONS
<b>1200</b>	<b>J</b>	<b>14</b>	<b>G</b>	<b>10</b>	<b>P</b>	<b>10</b>	<b>F</b>	<b>3</b>	<b>BA-GA</b>
Model	Sensor Type	OD	Junction	Sheath Length (inches)	Sheath Material	Lead Length (inches)	Lead Insulation		

Model No. Example

### SENSOR

#### SENSOR TYPE

J	Iron Constantan®
K	Chromel® Alumel®
T	Copper Constantan®
E	Chromel® Constantan®
N	Nicrosil® Nisil®
R	Platinum 13% Rhodium
	Pure Platinum
S	Platinum 10% Rhodium
	Pure Platinum

#### OD

125	1/25" (1.0 mm)
116	1/16" (1.6 mm)
18	1/8" (3.2 mm)
316	3/16" (4.8 mm)
14	1/4" (6.4 mm)
516	5/16" (7.9 mm)
38	3/8" (9.5 mm)

#### JUNCTION

G	Grounded
U	Ungrounded
E	Exposed
DG	Dual Grounded
DU	Dual Ungrounded
DE	Dual Exposed

#### SHEATH MATERIAL

P	304SS
R	316SS
Q	310SS
A	Alloy 600

Standard Sheath Material is 316SS. Other sheaths available.

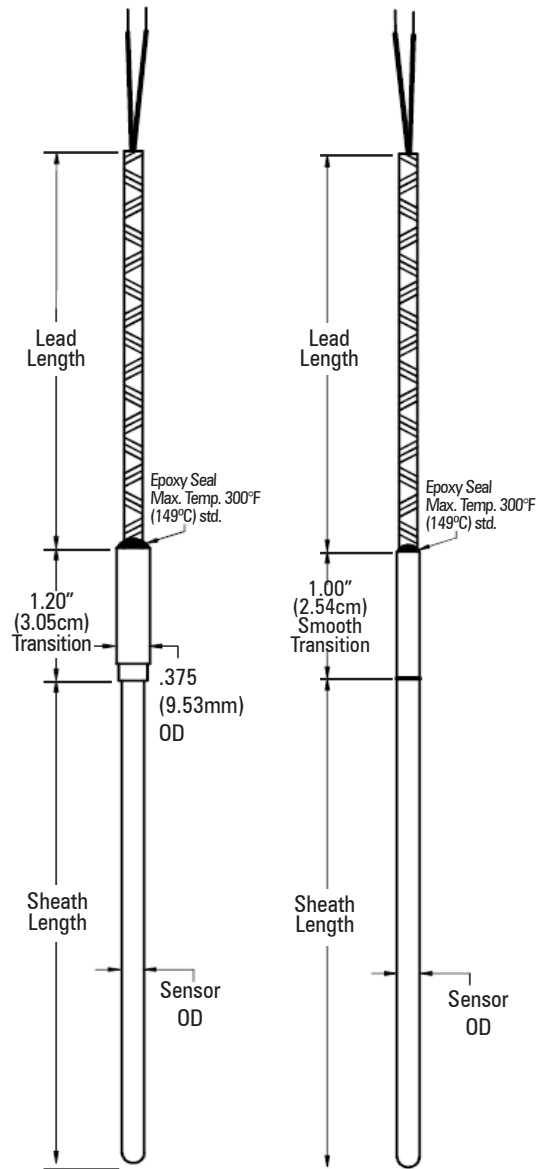

### LEAD INSULATION

F	Fiberglass 20 gauge solid
K	Kapton® 20 gauge solid
T	Teflon® 20 gauge solid
P	PVC 20 gauge solid
PS	PVC w/Shield and Drainwire 20 gauge solid
MF	Multi Strand (flexible) Fiberglass 20 gauge
MT	Multi Strand (flexible) Teflon® 20 gauge

### TERMINATION

1	Bare Ends	2 1/2" (6.35 cm) std.
2	Large Plug	
3	Miniature Plug	
4	Hi Temp Large Plug	
5	Large Jack	
6	Miniature Jack	
7	Hi Temp Large Jack	
8	Dual Large Plug*	
9	Dual Large Jack*	
11	Compensated Spade Lugs	
12	Three Pin Plug	
13	Three Pin Jack	

\* Two single connectors are bracketed for MI cable termination.

See page 27-28 for more details.

### OPTIONS

A	Armor (Stainless Steel)	BR18	Adj Brass Comp Fitting 1/8" NPT*	SS14	Adj SS Comp Fitting 1/4" NPT*
AP	Armor with PVC Jacket	BR14	Adj Brass Comp Fitting 1/4" NPT*	SS12	Adj SS Comp Fitting 1/2" NPT*
AT	Armor with Teflon® Jacket	BR12	Adj Brass Comp Fitting 1/2" NPT*	ST	Smooth Transition,
BA	Bayonet Adapter (Adjustable)	BS	Bell Spring Transition Relief		3/16" (4.8 mm) OD and larger
BF	Bayonet Cap & Spring, 1/8" (3.2 mm) and 3/16" (4.8 mm) OD only	CG12	Weather Tight Fitting 1/2" NPT	TA	Tube on Armor, 1/4" (6.4 mm) OD x 2" (50.8 mm) long
	Note: inches from cap to tip (fixed)	CV	Connector with Epoxy Sealed Screws	TF	Teflon® Coated Sheath
BD45	45° Bend in Sheath	DE12	Double Ended Hex Fitting, 1/2" NPT	VH	Vent Hole in Compression Fitting
	Note: inches from bend to tip	HTP	High Temperature Potting	WC	Wire Clamp Bracket for Leads
BD90	90° Bend in Sheath		Service over 400°F (204° C)	WP	Weld Pad, 1" (2.54 cm) x 1" (2.54 cm) x 1/8" (0.32 cm) SS
	Note: inches from bend to tip	LB	Connector "L" Bracket (Standard Plug Only)		*Add T after SS or BR for Teflon® Ferrule
		NT	No Transition		See page 22-23 for more options.
		SB	Stainless Steel Overbraided Leads		
		SS18	Adj SS Comp Fitting 1/8" NPT*		

## Remote Mounted Sensors – Model 1340

Model 1340 is easily installed, reduces vibration damage to the head and eliminates stocking several different lengths. This versatile design can be inserted into an existing well or used in other general purpose applications where a well or protection tube is not required. The exact immersion depth is not required when inserting in a well. Simply bottom the sensor to the bottom of the well and tighten the optional compression fitting. The 1340 allows a reduction in store room lengths due to this flexibility.

The flexible armor leads allows remote mounting of the head in applications where there is a very tight fit. In high temperature thermocouple applications it is recommended that sensor connections are in a area that has ambient temperatures below 400°F (204.4°C). The 1340 design allows the head to be mounted remotely, an option that can greatly enhance the accuracy of the measurement.

Select a designator for each component. There is a dash between each designator including options, i.e. CA-1340-J-14-G-10-P-10-F A-SS12-PT(32-100°C)-FR-10-AA-2.25-H-C-B-3-600-RF-FP. If not required leave blank.

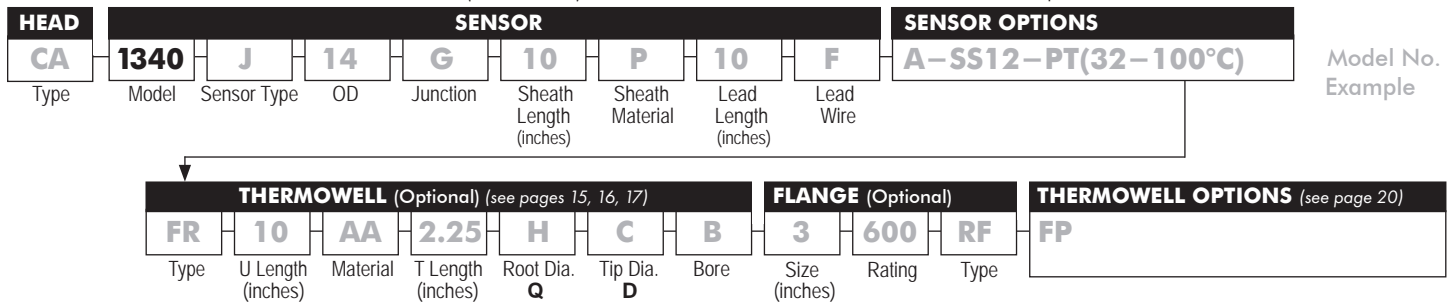

HEAD TYPE	
0	No Head
CA	Cast Aluminum
CI	Cast Iron
CSS	Cast Stainless Steel
PPS	Polypropylene Sanitary
FTA	Flip Top Aluminum
FTP	Flip Top Poly (white)
EPA	Explosion Proof Aluminum
EPS	Explosion Proof Stainless Steel
EHA	Explosion Proof Aluminum
EHI	Explosion Proof Iron
See page 24-25 for more details.	
SENSOR	
SENSOR TYPE	
J	Iron Constantan®
K	Chromel® Alumel®
T	Copper Constantan®
E	Chromel® Constantan®
N	Nicrosil® Nisil®
PO	Low Temp RTD to 500°F (260°C)
PH	High Temp RTD to 900°F (482°C)
PM	Heavy Duty RTD to 900°F (482°C)
Standard RTD is a three-wire 100 ohm Platinum / .00385 Alpha. For higher temperatures ranges - consult factory. For special limits on thermocouples, repeat calibration code, i.e. JJ.	
OD	
18	1/8" (3.2 mm)
316	3/16" (4.8 mm)
14	1/4" (6.4 mm)
516	5/16" (7.9 mm)
38	3/8" (9.5 mm)
JUNCTION	
G	Grounded
U	Ungrounded
E	Exposed
DG	Dual Grounded
DU	Dual Ungrounded
DE	Dual Exposed
S	Single RTD
D	Dual RTD

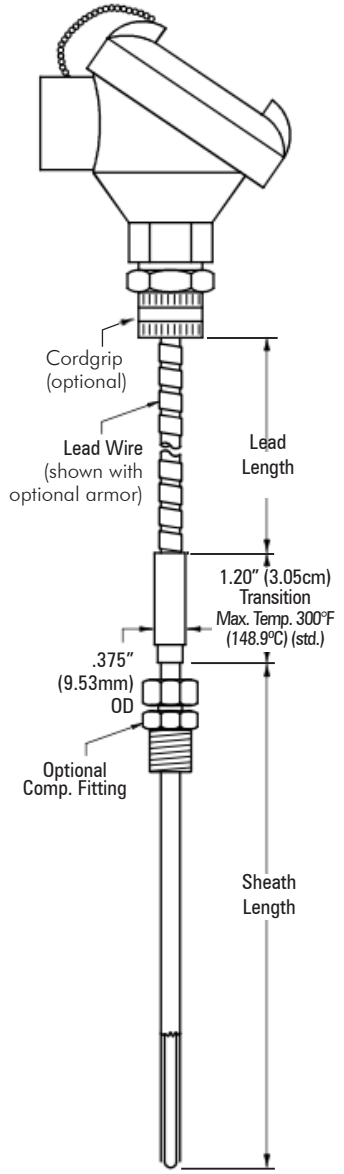

SHEATH MATERIALS	
P	304SS
R	316SS
Q	310SS
A	Alloy 600
Standard Sheath Material is 316SS.	
LEAD WIRE	
F	Fiberglass
T	Teflon®
P	PVC
PS	PVC Shielded
MF	Multi Strand (flexible) Fiberglass (RTD std.)
MT	Multi Strand (flexible) Teflon® (RTD std.)
OPTIONS	
SENSOR	
A	Armor (Stainless Steel)
AP	Armor with PVC Jacket
CG12	Cord Grip, 1/2" NPT
SS12	Adj SS Comp Fitting 1/2" NPT*
BR12	Adj Brass Comp Fitting 1/2" NPT*
VH	Vent hole for fittings
TA	Tube on Armor, 1/4" (6.4 mm) OD x 2" (50.8 cm) long
TAC	Tube on Armor with SS12 Fitting for Head Mount
SA12	Spring Assembly with Hex Fitting, 1/2" NPT
SB	Stainless Steel Overbraid on Lead Wire
HV	High Vibration RTD (PM only)
FW	Four Wire RTD
GA	Class A
*Add T after SS or BR for Teflon® Ferrule	
TRANSMITTER/INDICATOR	
PT	Programmable FM**
HC	Hart® Compatible**
LPI	Loop Temperature Indicator
BPI	Battery Powered Indicator
**Provide range and temperature F/C (i.e. PT(32-100 °C))	
See page 22-23 and 30, 31, 32, 33 for more options and details.	

The thermocouple and RTD designs for these sensors are multi-purpose but all can be easily installed in an existing thermowell. All thermocouples are made with high purity mineral oxide insulation and a high temperature stainless steel sheath. RTD's are selected by determining the temperature range and vibration considerations.

- Model 1440 has a sealed weld connection preventing hot gases from escaping and consequently can be used without a thermowell.
- Model 1443 is designed specifically for use in a thermowell and comes with a spring assembly which insures positive contact to the bottom of the well and provides good response characteristics.
- Model 1445 eliminates the need for an exact immersion length. Model 1450 is a sealed weld connection and the 1455 is adjustable with compression fitting. Tube well assemblies come with 0.020" (0.508 mm) wall tube and a replaceable spring loaded sensor made to fit the tube I.D.

HEAD TYPE	
O	No Head
CA	Cast Aluminum
CI	Cast Iron
CSS	Cast Stainless Steel
PPS	Polypropylene Sanitary
FTA	Flip Top Aluminum
FTP	Flip Top Poly (white)
EPA	Explosion Proof Aluminum
EPS	Explosion Proof Stainless Steel
EHA	Explosion Proof Aluminum

See page 24-25 for more details.

SENSOR/TUBEWELL	
SENSOR	TUBEWELL
1440	1450
1443	1455
1445	

SENSOR TYPE	
J	Iron Constantan®
K	Chromel® Alumel®
T	Copper Constantan®
E	Chromel® Constantan®
N	Nicrosil® Nisil®
PO	Low Temp RTD to 500°F (260°C)
PH	High Temp RTD to 900°F (482°C)
PM	Heavy Duty RTD to 900°F (482°C)

Standard RTD is a three-wire 100 ohm Platinum / 0.00385 Alpha. For higher temperature ranges - consult factory. For special limits on thermocouples, repeat calibration code, i.e. JJ.

OD Sensor	
18	1/8" (3.2 mm)
316	3/16" (4.8 mm)
14	1/4" (6.4 mm)
516	5/16" (7.9 mm)
38	3/8" (9.5 mm)

Tubewell	
316	3/16" (4.8 mm)
14	1/4" (6.4 mm)
516	5/16" (7.9 mm)
38	3/8" (9.5 mm)

JUNCTION	
G	Grounded
U	Ungrounded
DG	Dual Grounded
DU	Dual Ungrounded
S	Single RTD
D	Dual RTD

SHEATH MATERIALS	
P	304SS
R	316SS
Q	310SS
A	Alloy 600

Standard Sheath Material is 316SS.

Select a designator for each component. There is a dash between each designator including options, i.e. CA-1440-J-14-G-10-R-HC (32-100°C)-FR-10-R-2.25-H-C-B-2-300-RF-FP. If not required leave blank.

HEAD		SENSOR/TUBEWELL					SENSOR OPTIONS			THERMOWELL (Optional) *				FLANGE (Optional)			TW OPTIONS*			
CA	1440	J	14	G	10	R	HC (32-100°C)			FR	10	R	2.25	H	C	B	2	300	RF	FP
Type	Model	Sensor Type	OD	Junction	Length (inches)	Sheath Material	Type	U Length (inches)	Material	T Length (inches)	Root Dia. Q	Tip Dia. D	Bore	Size (inches)	Rating	Type				

\*see page 15, 16, 17 for selection.

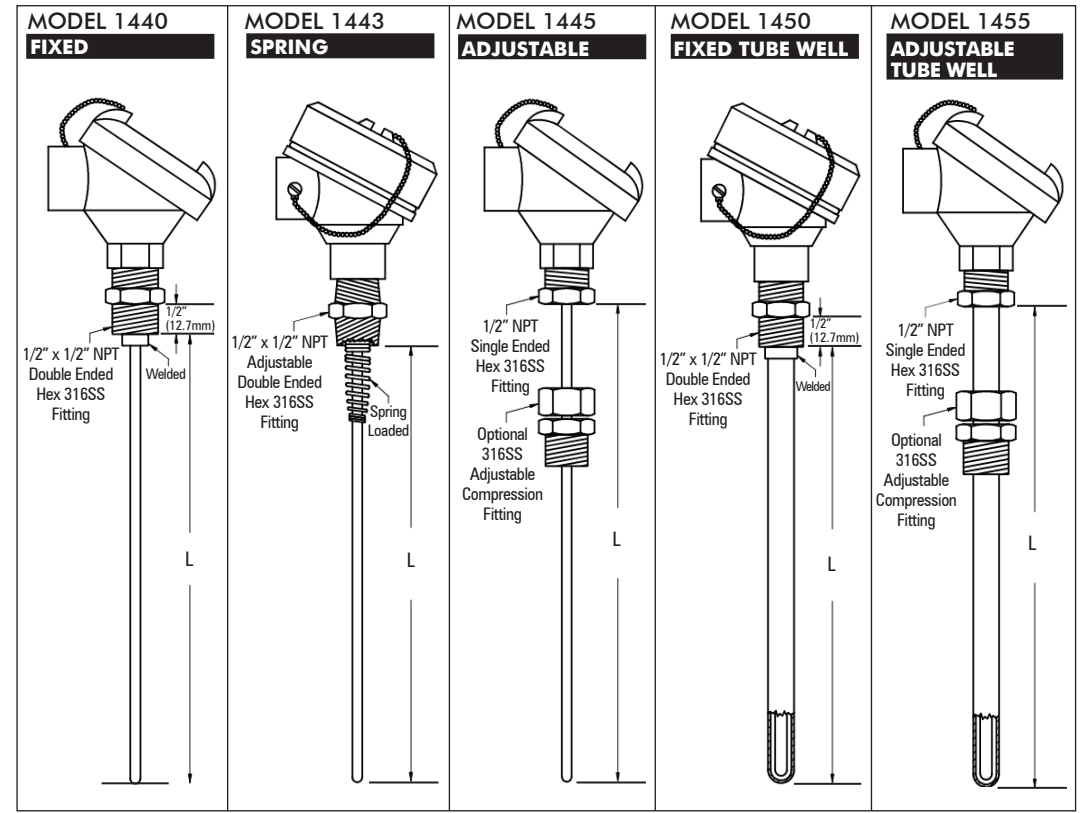

OPTIONS		SENSOR		TRANSMITTER/INDICATOR	
BR18	Adj Brass Comp Fitting 1/8" NPT*	HV	High Vibration (PM RTDs only)	HC	Hart® Compatible**
BR14	Adj Brass Comp Fitting 1/4" NPT*	SS18	Adj SS Comp Fitting 1/8" NPT*	LCP	Programmable, RTD
BR12	Adj Brass Comp Fitting 1/2" NPT*	SS14	Adj SS Comp Fitting 1/4" NPT*	PT	Programmable
CT	Compensated Terminals (EHA/EHI head only)	SS12	Adj SS Comp Fitting 1/2" NPT*	BPI	Battery Powered Indicator
FW	Four Wire RTD	TW	Two Wire RTD	LPI	Loop Temperature Indicator
GA	Class A	VH	Vent hole for fittings insert following fitting part no.	**Provide range and temperature F/C (i.e. PT(32-100 °C))	
		*Add T after SS or BR for Teflon® Ferrule			

See page 22-23 and 30, 31, 32, 33 for more options and details.

# Temperature Sensors

# Pipe Thermowell Assemblies

Select a designator for each component. There is a dash between each designator including options, i.e. CA-NU-3-J-14-G-R-PW0-14-A-1-SH. If not required leave blank.

• To order only a thermowell complete just those boxes. To add a nipple or nipple-union-nipple also include the extension code and "A" length.

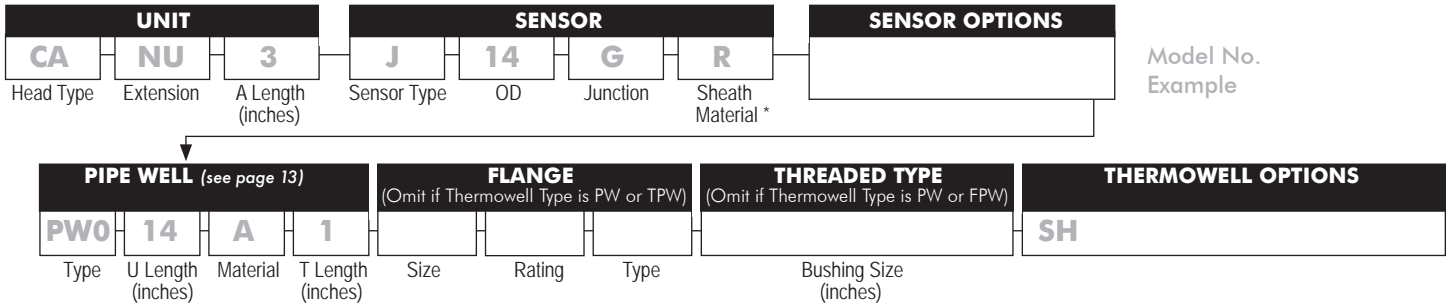

## UNIT

### HEAD TYPE

0	No Head	FTP	Flip Top Poly (white)
CA	Cast Aluminum	EPA	Explosion Proof Aluminum
CI	Cast Iron	EPS	Explosion Proof Stainless Steel
CSS	Cast Stainless Steel	EHA	Explosion Proof Aluminum
PPS	Polypropylene Sanitary	EHI	Explosion Proof Iron
FTA	Flip Top Aluminum		

See page 24-25 for more options.

### EXTENSION

0	None
NU	Nipple/Union Galvanized
NUS	Nipple/Union Stainless Steel

See page 26 for more options.

## THERMOWELL

**PIPE TYPE** - See page 13 to select.

**WELL MATERIAL** - See page 20 for more options.

A	Alloy 600	M	Monel® 400
AA	Alloy 20	N	Nickel
B	Hastelloy® B	P	304SS
C	Hastelloy® C	Q	310SS
D	321SS	R	316SS
F	347SS	S	Carbon Steel
H	446SS	T	Teflon®
I	Alloy 800	V	Alloy 825
LP	Low Carbon 304SS	W	Alloy 601
LR	Low Carbon 316SS	Y	Brass

## FLANGE

FLANGE SIZE	FLANGE RATING	FLANGE TYPE
1" (2.54 cm)	150	FF Flat Face
1.5" (3.81 cm)	200 600	RF Raised Face
2" (5.08 cm)	300 900	RTJ Ring Type Joint
3" (7.62 cm)	400 1500	
4" (10.16 cm)		

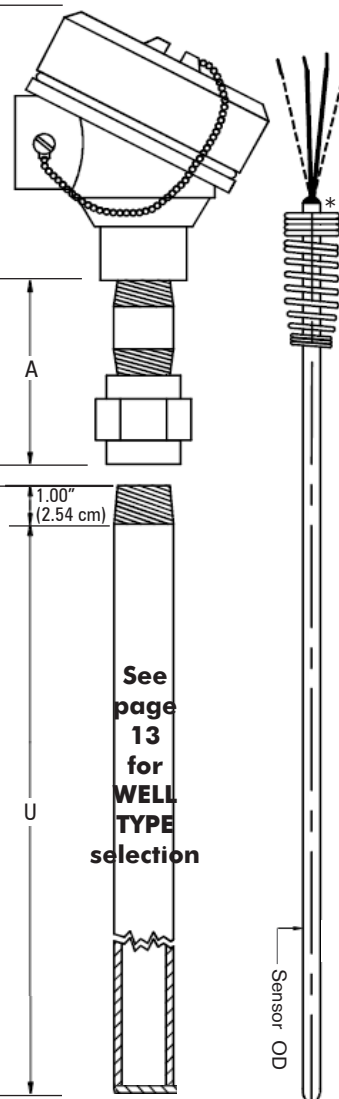

## SENSOR

### SENSOR TYPE

J	Iron Constantan®
K	Chromel® Alumel®
T	Copper Constantan®
E	Chromel® Constantan®
N	Nicrosil® Nisil®
PO	Low Temp RTD to 500°F (260°C)
PH	High Temp RTD to 900°F (482°C)
PM	Heavy Duty RTD to 900°F (482°C)

Standard RTD is a three-wire 100 ohm Platinum / 0.00385 Alpha. For higher temperature ranges - consult factory. For special limits on thermocouples, repeat calibration code, i.e. JJ.

### OD

316	3/16" (4.8 mm)
14	1/4" (6.4 mm)
516	5/16" (7.9 mm)
38	3/8" (9.5 mm)

### JUNCTION

G	Grounded
U	Ungrounded
E	Exposed
DG	Dual Grounded
DU	Dual Ungrounded
DE	Dual Exposed
S	Single RTD
D	Dual RTD

### SHEATH MATERIALS

P	304SS
R	316SS
Q	310SS
A	Alloy 600

Standard Sheath Material is 316SS.

\* Epoxy Seal - Max. Temp. 300°F (149°C)

## OPTIONS

### SENSOR

CR	Cryogenic RTD (PM only)
CT	Compensated Terminals (EHA/EHI head only)
FW	Four Wire RTD
HV	High Vibration RTD (PM only)
GA	Class A

### THERMOWELL

FP	Full Penetration Weld
HTE	Hydrostatic Pressure Test External
HTI	Hydrostatic Pressure Test Internal
MC	MTR/Mill Certificate
NC	NACE Certification for Well
OC	Oxygen Cleaned

SH	Schedule 80
ST	Stellite® Coating
SX	Schedule 160
SXX	Double Extra Heavy
TC	Tungsten Carbide
TF	Teflon® Coating

### TRANSMITTER/INDICATOR

BPI	Battery Powered Indicator
HC	Hart® Compatible
	Provide Range and Temp F/C
LCP	Programmable, RTD
LPI	Loop Temperature Indicator
PT	Programmable

See page 22-23 and 30, 31, 32, 33 for more options and details.

# Temperature Sensors

## Pipe Thermowell Options Pipe, Flanged and Threaded

Select a designator for each component. There is a dash between each designator including options, i.e. PW0-18-AA-3. If not required leave blank.

THERMOWELL				FLANGE (Omit if Thermowell Type is PW or TPW)			THREADED TYPE (Omit if Thermowell Type is PW or FPW)		THERMOWELL OPTIONS
PW0	18	AA	3						
Type	U Length (inches)	Material*	T Length (inches)	Size (inches)	Rating	Type	Bushing Size (inches)		

\*See page 20 for selection.

### PIPE

Type*	Pipe Size	OD	ID			
			SCH40	SCH80	SCH 160	XXH
PW	1/2" NPT	0.840" (21.8 mm)	0.622" (15.8 mm)	0.546" (13.9 mm)	0.466" (11.8 mm)	0.252" (6.4 mm)
PW0	3/4" NPT	1.050" (26.8 mm)	0.824" (20.9 mm)	0.742" (18.9 mm)	0.614" (15.6 mm)	0.434" (11.0 mm)
PW1	1" NPT	1.315" (33.4 mm)	1.049" (26.6 mm)	0.957" (24.3 mm)	0.815" (20.7 mm)	0.599" (15.2 mm)
PW2	1 1/4" NPT	1.660" (42.2 mm)	1.380" (35.1 mm)	1.278" (32.5 mm)	1.160" (29.5 mm)	0.896" (22.8 mm)

\* Schedule 40 is standard. See options for other schedules.

### FLANGED PIPE

Type*	Pipe Size	OD	ID			
			SCH40	SCH80	SCH 160	XXH
FPW	1/2" NPT	0.840" (21.8 mm)	0.622" (15.8 mm)	0.546" (13.9 mm)	0.466" (11.8 mm)	0.252" (6.4 mm)
FPW0	3/4" NPT	1.050" (26.8 mm)	0.824" (20.9 mm)	0.742" (18.9 mm)	0.614" (15.6 mm)	0.434" (11.0 mm)
FPW1	1" NPT	1.315" (33.4 mm)	1.049" (26.6 mm)	0.957" (24.3 mm)	0.815" (20.7 mm)	0.599" (15.2 mm)
FPW2	1 1/4" NPT	1.660" (42.2 mm)	1.380" (35.1 mm)	1.278" (32.5 mm)	1.160" (29.5 mm)	0.896" (22.8 mm)

FLANGE		
Size	Rating	Type
1" (2.54 cm)	150	RF Raised Face
1.5" (3.81 cm)	200	FF Flat Face
2" (5.08 cm)	300	RTJ Ring Type Joint
3" (7.62 cm)	400	
4" (10.16 cm)	600	
	900	
	1500	

\* Flanges made from same material as pipe. Schedule 40 is standard. See options for other schedules.

### THREADED PIPE

Type*	Pipe Size	OD	ID				Std. Mounting Bushing**
			SCH40	SCH80	SCH 160	XXH	
TPW	1/2" NPT	0.840" (21.8 mm)	0.622" (15.8 mm)	0.546" (13.9 mm)	0.466" (11.8 mm)	0.252" (6.4 mm)	0.75" (19.1 mm), 1" (25.4 mm), 1.25" (31.8 mm), 1.5" (38.1 mm)
TPW0	3/4" NPT	1.050" (26.8 mm)	0.824" (20.9 mm)	0.742" (18.9 mm)	0.614" (15.6 mm)	0.434" (11.0 mm)	1" (25.4 mm), 1.25" (31.8 mm), 1.5" (38.1 mm), 2" (50.8 mm)
TPW1	1" NPT	1.315" (33.4 mm)	1.049" (26.6 mm)	0.957" (24.3 mm)	0.815" (20.7 mm)	0.599" (15.2 mm)	1.25" (31.8 mm), 1.5" (38.1 mm), 2" (50.8 mm), 2.5" (63.5 mm)
TPW2	1 1/4" NPT	1.660" (42.2 mm)	1.380" (35.1 mm)	1.278" (32.5 mm)	1.160" (29.5 mm)	0.896" (22.8 mm)	2" (50.8 mm), 2.5" (63.5 mm)

\* Schedule 40 is standard. See options for other schedules.  
\*\* Bushing will be 304SS unless otherwise noted.

Select a designator for each component. There is a dash between each designator including options, i.e. EPA-N-6-J-14-G-R-10-AA-10-R-E-B-2-300-RF-FP. If not required leave blank.

- To order only a thermowell complete just those boxes. To add a nipple or nipple-union-nipple also include the extension code and "A" length.

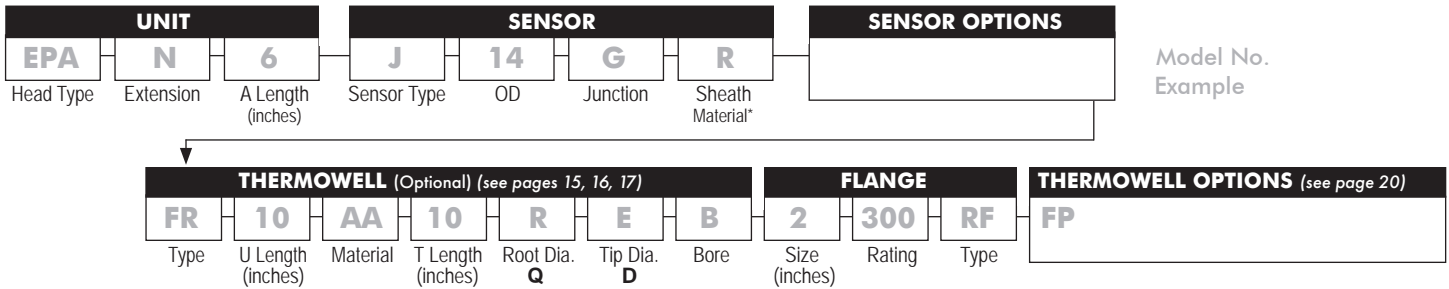

UNIT		SENSOR																			
<b>HEAD TYPE</b> 0 No Head CA Cast Aluminum CI Cast Iron CSS Cast Stainless Steel FTA Flip Top Aluminum FTP Flip Top Poly (white)		EPA Explosion Proof Aluminum EPS Explosion Proof Stainless Steel EHA Explosion Proof Aluminum EHI Explosion Proof Iron PPS Polypropylene Sanitary <i>See page 24-25 for more details.</i>																			
<b>EXTENSION</b> N Nipple Galvanized NUN Nipple/Union/Nipple Galvanized NS Nipple Stainless Steel NUNS Nipple/Union/Nipple Stainless Steel HUNS Hex Nipple/Union/Nipple Stainless Steel PNUN Pressure Seal in Union Galvanized PNUNS Pressure Seal in Union Stainless Steel <i>See page 26 for more details.</i>		<b>WELL TYPE</b> - See page 15-16-17 to select. <b>WELL MATERIAL</b> - See page 20 for more options. A Alloy 600 AA Alloy 20 C Hastelloy® C D 321SS F 347SS H 446SS I Alloy 800 LP Low Carbon 304SS LR Low Carbon 316SS M Monel® 400 N Nickel P 304SS Q 310SS R 316SS S Carbon Steel T Teflon® W Alloy 601 Y Brass																			
<b>THERMOWELL (Optional)</b> <b>FLANGE (Optional)</b> <table border="1"> <thead> <tr> <th>FLANGE SIZE</th> <th>FLANGE RATING</th> <th>FLANGE TYPE</th> </tr> </thead> <tbody> <tr> <td>1" (2.54 cm)</td> <td>150 600</td> <td>FF Flat Face</td> </tr> <tr> <td>1.5" (3.81 cm)</td> <td>200 900</td> <td>RF Raised Face</td> </tr> <tr> <td>2" (5.08 cm)</td> <td>300 1500</td> <td>RTJ Ring Type Joint</td> </tr> <tr> <td>3" (7.62 cm)</td> <td>400</td> <td></td> </tr> <tr> <td>4" (10.16 cm)</td> <td></td> <td></td> </tr> </tbody> </table>		FLANGE SIZE	FLANGE RATING	FLANGE TYPE	1" (2.54 cm)	150 600	FF Flat Face	1.5" (3.81 cm)	200 900	RF Raised Face	2" (5.08 cm)	300 1500	RTJ Ring Type Joint	3" (7.62 cm)	400		4" (10.16 cm)			<b>JUNCTION</b> G Grounded U Ungrounded E Exposed DG Dual Grounded DU Dual Ungrounded DE Dual Exposed S Single RTD D Dual RTD	
FLANGE SIZE	FLANGE RATING	FLANGE TYPE																			
1" (2.54 cm)	150 600	FF Flat Face																			
1.5" (3.81 cm)	200 900	RF Raised Face																			
2" (5.08 cm)	300 1500	RTJ Ring Type Joint																			
3" (7.62 cm)	400																				
4" (10.16 cm)																					
<b>FLANGE (Optional)</b> <table border="1"> <thead> <tr> <th>FLANGE SIZE</th> <th>FLANGE RATING</th> <th>FLANGE TYPE</th> </tr> </thead> <tbody> <tr> <td>1" (2.54 cm)</td> <td>150 600</td> <td>FF Flat Face</td> </tr> <tr> <td>1.5" (3.81 cm)</td> <td>200 900</td> <td>RF Raised Face</td> </tr> <tr> <td>2" (5.08 cm)</td> <td>300 1500</td> <td>RTJ Ring Type Joint</td> </tr> <tr> <td>3" (7.62 cm)</td> <td>400</td> <td></td> </tr> <tr> <td>4" (10.16 cm)</td> <td></td> <td></td> </tr> </tbody> </table>		FLANGE SIZE	FLANGE RATING	FLANGE TYPE	1" (2.54 cm)	150 600	FF Flat Face	1.5" (3.81 cm)	200 900	RF Raised Face	2" (5.08 cm)	300 1500	RTJ Ring Type Joint	3" (7.62 cm)	400		4" (10.16 cm)			<b>SENSOR</b> <b>SENSOR TYPE</b> J Iron Constantan® K Chromel® Alumel® T Copper Constantan® E Chromel® Constantan® N Nicrosil® Nisil® PO Low Temp RTD to 500°F (260°C) PH High Temp RTD to 900°F (482°C) PM Heavy Duty RTD to 900°F (482°C) Standard RTD is a three-wire 100 ohm Platinum / 0.00385 Alpha. For higher temperature ranges - consult factory. For special limits on thermocouples, repeat calibration code, i.e. JJ. <b>OD</b> 18 1/8" (3.2 mm) 316 3/16" (4.8 mm) 14 1/4" (6.4 mm) 516 5/16" (7.9 mm) 38 3/8" (9.5 mm)	
FLANGE SIZE	FLANGE RATING	FLANGE TYPE																			
1" (2.54 cm)	150 600	FF Flat Face																			
1.5" (3.81 cm)	200 900	RF Raised Face																			
2" (5.08 cm)	300 1500	RTJ Ring Type Joint																			
3" (7.62 cm)	400																				
4" (10.16 cm)																					
<b>FLANGE (Optional)</b> <table border="1"> <thead> <tr> <th>FLANGE SIZE</th> <th>FLANGE RATING</th> <th>FLANGE TYPE</th> </tr> </thead> <tbody> <tr> <td>1" (2.54 cm)</td> <td>150 600</td> <td>FF Flat Face</td> </tr> <tr> <td>1.5" (3.81 cm)</td> <td>200 900</td> <td>RF Raised Face</td> </tr> <tr> <td>2" (5.08 cm)</td> <td>300 1500</td> <td>RTJ Ring Type Joint</td> </tr> <tr> <td>3" (7.62 cm)</td> <td>400</td> <td></td> </tr> <tr> <td>4" (10.16 cm)</td> <td></td> <td></td> </tr> </tbody> </table>		FLANGE SIZE	FLANGE RATING	FLANGE TYPE	1" (2.54 cm)	150 600	FF Flat Face	1.5" (3.81 cm)	200 900	RF Raised Face	2" (5.08 cm)	300 1500	RTJ Ring Type Joint	3" (7.62 cm)	400		4" (10.16 cm)			<b>WELL TYPE</b> - See page 15-16-17 to select. <b>WELL MATERIAL</b> - See page 20 for more options. A Alloy 600 AA Alloy 20 C Hastelloy® C D 321SS F 347SS H 446SS I Alloy 800 LP Low Carbon 304SS LR Low Carbon 316SS M Monel® 400 N Nickel P 304SS Q 310SS R 316SS S Carbon Steel T Teflon® W Alloy 601 Y Brass <b>JUNCTION</b> G Grounded U Ungrounded E Exposed DG Dual Grounded DU Dual Ungrounded DE Dual Exposed S Single RTD D Dual RTD <b>SEATH MATERIALS</b> P 304SS R 316SS Q 310SS A Alloy 600 Standard Sheath Material is 316SS. * Epoxy Seal - Max. Temp. 300°F (149°C)	
FLANGE SIZE	FLANGE RATING	FLANGE TYPE																			
1" (2.54 cm)	150 600	FF Flat Face																			
1.5" (3.81 cm)	200 900	RF Raised Face																			
2" (5.08 cm)	300 1500	RTJ Ring Type Joint																			
3" (7.62 cm)	400																				
4" (10.16 cm)																					

OPTIONS		THERMOWELL		TRANSMITTER/INDICATOR	
<b>SENSOR</b> FW Four Wire RTD GA Class A HV High Vibration RTD (PM only)		FP Full Penetration Weld HTE Hydrostatic Pressure Test External HTI Hydrostatic Pressure Test Internal MC MTR/Mill Certificate OC Oxygen Cleaned		SC SS Plug and Chain ST Stellite® Coating VC Velocity Calculations Other bore sizes available, consult factory.	
<i>See page 22-23 and 30, 31, 32, 33 for more options and details.</i>				BPI Battery Powered Indicator HC Hart® Compatible Provide Range and Temp F/C LCP Programmable, RTD LPI Loop Temperature Indicator PT Programmable	

# Temperature Sensors

## Thermowells Threaded and Flanged

Select a designator for each component. There is a dash between each designator including options, i.e. SR0-12-R-2.25-R-E-B-1.5-300-RF-A. If not required leave blank.

THERMOWELL (see pages 15-16 for selections)						FLANGE			THERMOWELL OPTIONS (see page 20)	
SR0	12	R	2.25	R	E	B	1.5	300	RF	A
Type	U Length* (inches)	Material**	T Length (inches)	Root Dia. Q	Tip Dia.** D	Bore**	Size (inches)	Rating	Type	

### THREADED - STRAIGHT

Type	Process NPT	Standard	
		Root Dia. Q	Tip Dia. D
SS	1/2"	0.680" (17.3 mm)	
SS0	3/4"	3/4" (19.1 mm)	
SS1	1"	7/8" (22.2 mm)	
SS2	1 1/4"	1 1/8" (28.6 mm)	
SS3	1 1/2"	1 1/8" (28.6 mm)	

See page 17 for Limited Space drawing for U dimension of 1.625".

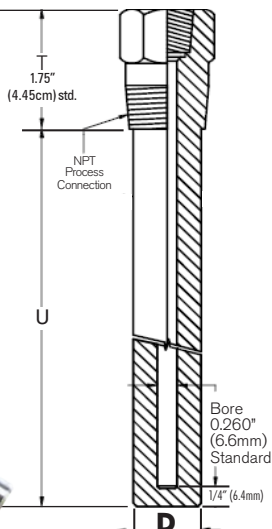

### FLANGED - STRAIGHT

Type	Description
FS	Straight Flanged

Size	Rating	Type
1"*** (2.54 cm)	150	RF Raised Face
1.5" (3.81 cm)	200	FF Flat Face
2" (5.08 cm)	300	RTJ Ring Type Joint
3" (7.62 cm)	400	
4" (10.16 cm)	600	
	900	
	1500	

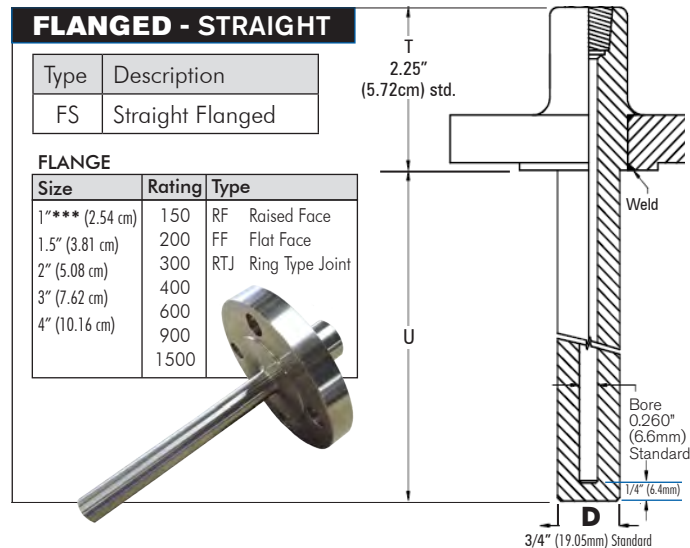

### THREADED - TAPERED

Type	NPT Process	Standard Dimensions	
		Root Dia. Q	Tip Dia. D
ST	1/2"	0.680" (17.3 mm)	5/8" (15.9 mm)
ST0	3/4"	7/8" (22.2 mm)	5/8" (15.9 mm)
ST1	1"	1 1/16" (26.0 mm)	5/8" (15.9 mm)
ST2	1 1/4"	1 1/8" (28.6 mm)	3/4" (19.1 mm)
ST3	1 1/2"	1 1/8" (28.6 mm)	3/4" (19.1 mm)

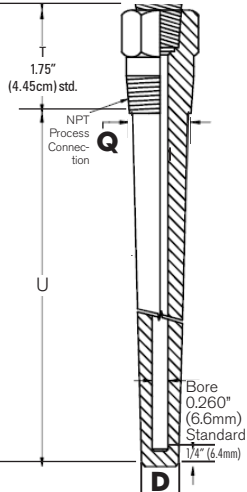

### FLANGED - TAPERED

Type	Description
FT	Tapered Flanged

Size	Rating	Type
1"*** (2.54 cm)	150	RF Raised Face
1.5" (3.81 cm)	200	FF Flat Face
2" (5.08 cm)	300	RTJ Ring Type Joint
3" (7.62 cm)	400	
4" (10.16 cm)	600	
	900	
	1500	

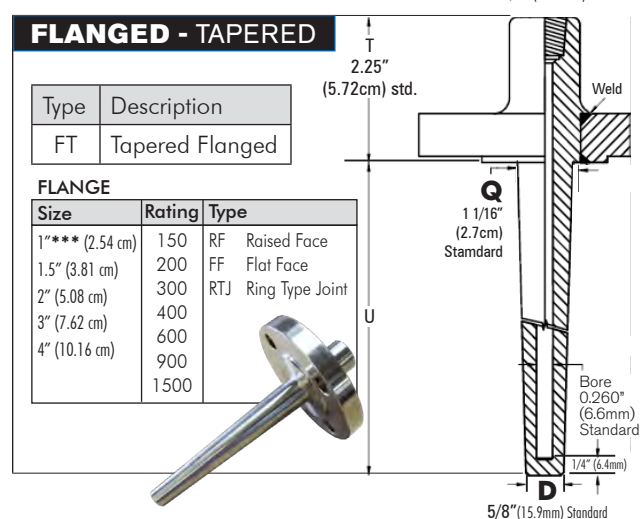

### THREADED - STEP-DOWN

Type	NPT Process	Standard Dimensions	
		Root Dia. Q	Tip Dia. D
SR	1/2"	5/8" (15.9 mm)	1/2" (12.7 mm)
SR0	3/4"	3/4" (19.1 mm)	1/2" (12.7 mm)
SR1	1"	7/8" (22.2 mm)	1/2" (12.7 mm)
SR2	1 1/4"	1 1/8" (28.6 mm)	3/4" (19.1 mm)
SR3	1 1/2"	1 1/8" (28.6 mm)	3/4" (19.1 mm)

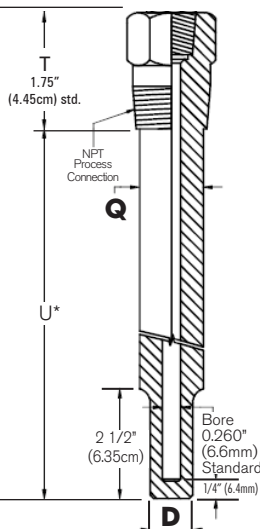

### FLANGED - STEP-DOWN

Type	Description
FR	Step-down Flanged

Size	Rating	Type
1"*** (2.54 cm)	150	RF Raised Face
1.5" (3.81 cm)	200	FF Flat Face
2" (5.08 cm)	300	RTJ Ring Type Joint
3" (7.62 cm)	400	
4" (10.16 cm)	600	
	900	
	1500	

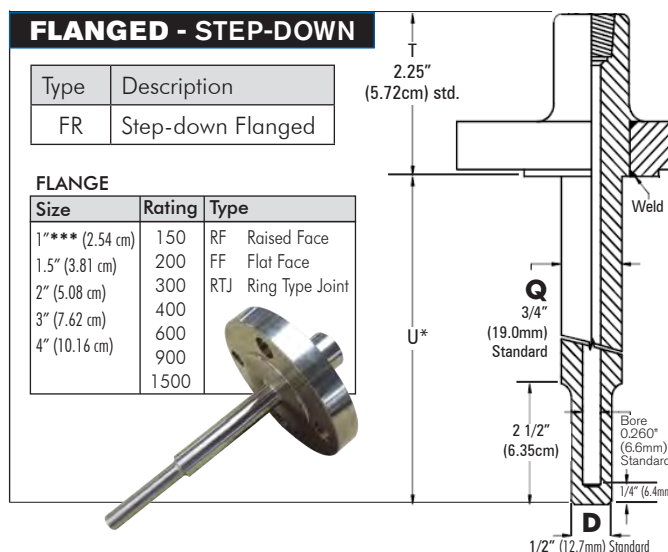

\*Step-Down options not available if "U" ≤ 2.5". Use straight option.

\*\* See page 20 for material, bore, root diameter and tip diameter selections.

\*\*\* Stem "Q" dimension is 0.875" for 1" flange size.

### SOCKET - STRAIGHT

Type	NPT Process	Actual Dia. P	Tip Dia. D
SWS**	1/2"	0.84" (21.226 mm)	0.680" (17.272 mm)
SWS0	3/4"	1.05" (26.67 mm)	0.75" (19.05 mm)
SWS1	1"	1.315" (33.40 mm)	0.875" (22.225 mm)

Note: To fit 3,000 lbs (1360.78 kg) coupling.  
\*\* Instrument connection equals 1.062" (2.70 cm) OD

### VAN STONE - STRAIGHT

Type	NPT Process	Actual Dia. P	Raised Face Dia. R
VS1	1"	1.315" (3.34 cm)	2" (5.08 cm)
VS3	1 1/2"	1.900" (4.83 cm)	2.875" (7.30 cm)
VS4	2"	2.375" (6.03 cm)	3.625" (9.21 cm)

### SOCKET - TAPERED

Type	NPT Process	Actual Dia. P	Root Dia. Q	Tip Dia. D
SWT**	1/2"	0.840" (21.2mm)	0.680" (17.3 mm)	0.625" (15.9 mm)
SWT0	3/4"	1.050" (26.7 mm)	0.875" (22.22 mm)	0.625" (15.9 mm)
SWT1	1"	1.315" (33.4 mm)	1.063" (27 mm)	0.625" (15.9 mm)
SWT2	1 1/4"	1.66" (42.2 mm)	1.125" (28.56 mm)	0.75" (19.1 mm)
SWT3	1 1/2"	1.90" (48.3 mm)	1.375" (34.9 mm)	0.875" (22.2 mm)
SWT4	2"	2.375" (60.3 mm)	1.75" (44.5 mm)	1.250" (31.8 mm)

Note: To fit 3,000 lbs (1360.78 kg) coupling.  
\*\* Instrument connection equals 1.062" (2.7 cm) OD

### VAN STONE - TAPERED

Type	NPT Process	Actual Dia. P	Raised Face Dia. R	Root Dia. Q	Tip Dia. D
VT1	1"	1.315" (33.4 mm)	2" (5.08 cm)	0.875" (22.2 mm)	0.625" (15.9 mm)
VT3	1 1/2"	1.90" (48.3 mm)	2.875" (7.30 cm)	1.063" (27 mm)	0.625" (15.9 mm)
VT4	2"	2.375" (60.3 mm)	3.625" (9.21 cm)	1.375" (34.9 mm)	0.875" (22.2 mm)

### SOCKET - STEP-DOWN

Type	NPT Process	Actual Dia. P	Root Dia. Q
SWR**	1/2"	0.840" (21.2 mm)	0.680" (17.3mm)
SWR0	3/4"	1.050" (26.7 mm)	0.75" (19.01 mm)
SWR1	1"	1.315" (33.4 mm)	0.875" (22.2 mm)

Note: To fit 3,000 lbs (1360.78 kg) coupling.  
\*\* Instrument connection equals 1.062" (2.7 cm) OD

### VAN STONE - STEP-DOWN

Type	NPT Process	Actual Dia. P	Raised Face Dia. R	Root Dia. Q	Tip Dia. D
VR1	1"	1.315" (3.34 cm)	2" (5.08 cm)	0.75" (19.05 mm)	0.5" (12.7mm)
VR3	1 1/2"	1.900" (4.83 cm)	2.875" (7.30 cm)	0.875" (2.22 mm)	0.5" (12.7mm)
VR4	2"	2.375" (6.03 cm)	3.625" (9.21 cm)	1.25" (3.17 cm)	0.875" (22.2mm)

\*Step-Down options not available if "U" ≤ 2.5". Use straight option.



## SANITARY - STRAIGHT

Type	NPT Process	Cap A	Cap B
SAS10	1"	1.984" (5.04 cm)	0.250" (6.4 mm)
SAS15	1 1/2"	1.984" (5.04 cm)	0.250" (6.4 mm)
SAS20	2"	2.516" (6.39 cm)	0.250" (6.4 mm)
SAS25	2 1/2"	3.047" (7.74 cm)	0.250" (6.4 mm)
SAS30	3"	3.579" (9.09 cm)	0.250" (6.4 mm)
SAS40	4"	4.682" (11.89 cm)	0.312" (7.9 mm)

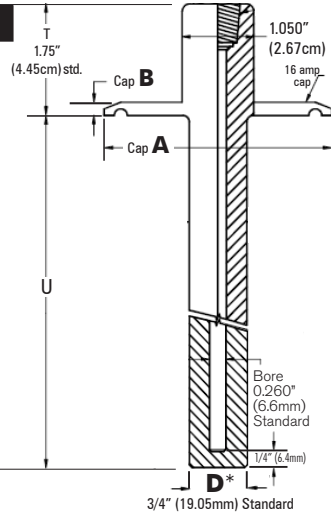

## WELD IN

Type	NPT Process	Actual Dia. P
WD0	3/4"	1.050" (2.67 cm)
WD1	1"	1.315" (3.34 cm)
WD2	1 1/4"	1.660" (4.22 cm)
WD3	1 1/2"	1.900" (4.83 cm)

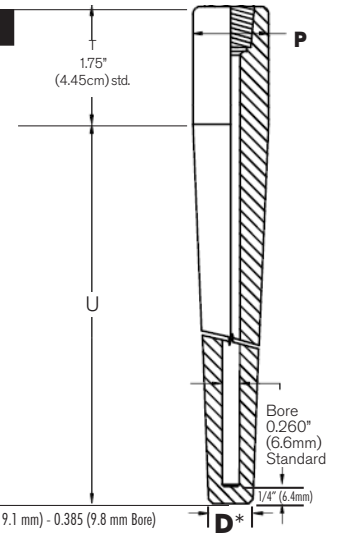

Standard (D=5/8" (15.8 mm) - 0.260 Bore) (D=3/4" (19.1 mm) - 0.385 (9.8 mm Bore)

## SANITARY - TAPERED

Type	NPT Process	Cap A	Cap B
SAT10	1"	1.984" (5.04 cm)	0.250" (6.4 mm)
SAT15	1 1/2"	1.984" (5.04 cm)	0.250" (6.4 mm)
SAT20	2"	2.516" (6.39 cm)	0.250" (6.4 mm)
SAT25	2 1/2"	3.047" (7.74 cm)	0.250" (6.4 mm)
SAT30	3"	3.579" (9.09 cm)	0.250" (6.4 mm)
SAT40	4"	4.682" (11.89 cm)	0.312" (7.9 mm)

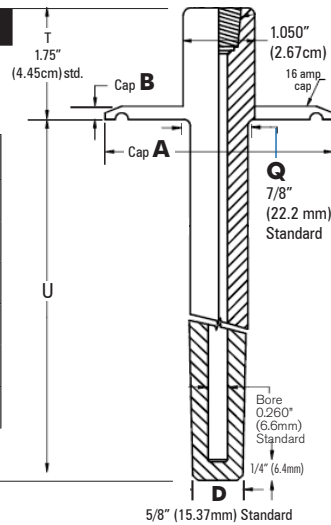

5/8" (15.37mm) Standard

## SANITARY - STEP-DOWN

Type	NPT Process	Cap A	Cap B
SAR10	1"	1.984" (5.04 cm)	0.250" (6.4 mm)
SAR15	1 1/2"	1.984" (5.04 cm)	0.250" (6.4 mm)
SAR20	2"	2.516" (6.39 cm)	0.250" (6.4 mm)
SAR25	2 1/2"	3.047" (7.74 cm)	0.250" (6.4 mm)
SAR30	3"	3.579" (9.09 cm)	0.250" (6.4 mm)
SAR40	4"	4.682" (11.89 cm)	0.312" (7.9 mm)

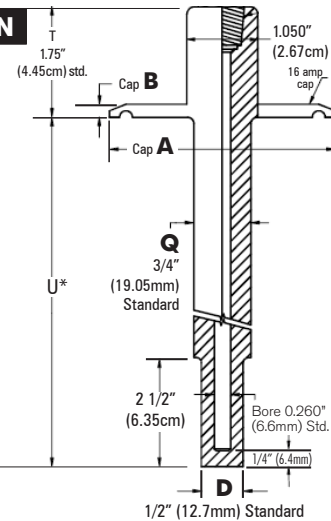

1/2" (12.7mm) Standard

## LIMITED SPACE - THREADED STRAIGHT

for U length of 1.625". See page 15.

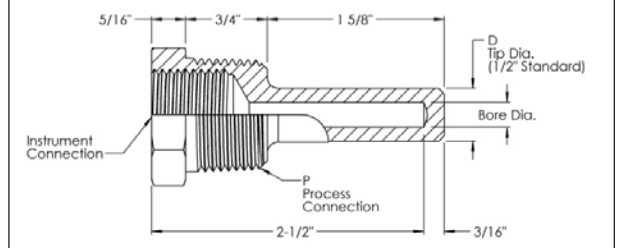

\*Step-Down options not available if "U" ≤ 2.5". Use straight option.

Sample probes are used in applications where a representative sample needs to be extracted from a process. Using a sample probe with a valve in a nozzle allows for simple and controlled extraction. Built of high quality materials so they stand up to the materials being sampled. Application engineering assistance is available including wake frequency calculations and custom probe design such as:

- Flanged or threaded style
- Bore diameters
- Retractable style
- Single or multiple valves
- Additional functionalities such as pressure or temperature measurement

Select a designator for each component. There is a dash between each designator including options, i.e. SPWO-18-AA-3-1-150-RF-2-A-BF-SA. If not required leave blank.

SAMPLE PROBE				FLANGE (Omit if Thermowell Type is SPW or STPW)			THREADED TYPE (Omit if Thermowell Type is SPW or SFPW)	SAMPLE PROBE OPTIONS
SPWO	18	AA	3	1	150	RF	2	A-BF-SA
Type	U Length (inches)	Material*	T Length (inches)	Size	Rating	Type	Bushing Size (inches)	

\*See page 20 for selection.

PIPE						
Type*	Pipe Size	OD	ID			
			SCH40	SCH80	SCH 160	XXH
SPW	1/2" NPT	0.840" (21.8 mm)	0.622" (15.8 mm)	0.546" (13.9 mm)	0.466" (11.8 mm)	0.252" (6.4 mm)
SPWO	3/4" NPT	1.050" (26.8 mm)	0.824" (20.9 mm)	0.742" (18.9 mm)	0.614" (15.6 mm)	0.434" (11.0 mm)
SPW1	1" NPT	1.315" (33.4 mm)	1.049" (26.6 mm)	0.957" (24.3 mm)	0.815" (20.7 mm)	0.599" (15.2 mm)
SPW2	1 1/4" NPT	1.660" (42.2 mm)	1.380" (35.1 mm)	1.278" (32.5 mm)	1.160" (29.5 mm)	0.896" (22.8 mm)

\* Schedule 40 is standard. See options for other schedules.

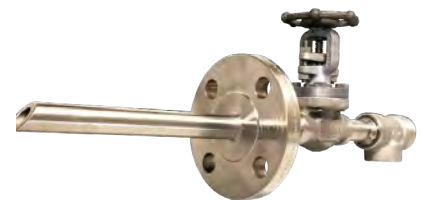
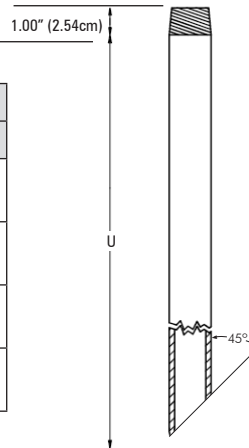

FLANGED PIPE						
Type*	Pipe Size	OD	ID			
			SCH40	SCH80	SCH 160	XXH
SFPW	1/2" NPT	0.840" (21.8 mm)	0.622" (15.8 mm)	0.546" (13.9 mm)	0.466" (11.8 mm)	0.252" (6.4 mm)
SFPWO	3/4" NPT	1.050" (26.8 mm)	0.824" (20.9 mm)	0.742" (18.9 mm)	0.614" (15.6 mm)	0.434" (11.0 mm)
SFPW1	1" NPT	1.315" (33.4 mm)	1.049" (26.6 mm)	0.957" (24.3 mm)	0.815" (20.7 mm)	0.599" (15.2 mm)
SFPW2	1 1/4" NPT	1.660" (42.2 mm)	1.380" (35.1 mm)	1.278" (32.5 mm)	1.160" (29.5 mm)	0.896" (22.8 mm)

\* Flanges made from same material as pipe. Schedule 40 is standard. See options for other schedules.

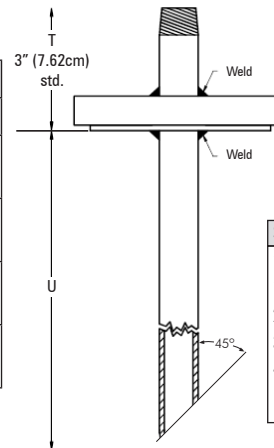

FLANGE		
Size	Rating	Type
1" (2.54 cm)	150	RF Raised Face
1.5" (3.81 cm)	200	FF Flat Face
2" (5.08 cm)	300	RTJ Ring Type Joint
3" (7.62 cm)	400	
4" (10.16 cm)	600	
	900	
	1500	

THREADED PIPE							Std. Mounting Bushing**
Type*	Pipe Size	OD	ID				
			SCH40	SCH80	SCH 160	XXH	
STPW	1/2" NPT	0.840" (21.8 mm)	0.622" (15.8 mm)	0.546" (13.9 mm)	0.466" (11.8 mm)	0.252" (6.4 mm)	0.75" (19.1 mm), 1" (25.4 mm), 1.25" (31.8 mm), 1.5" (38.1 mm)
STPWO	3/4" NPT	1.050" (26.8 mm)	0.824" (20.9 mm)	0.742" (18.9 mm)	0.614" (15.6 mm)	0.434" (11.0 mm)	1" (25.4 mm), 1.25" (31.8 mm), 1.5" (38.1 mm), 2" (50.8 mm)
STPW1	1" NPT	1.315" (33.4 mm)	1.049" (26.6 mm)	0.957" (24.3 mm)	0.815" (20.7 mm)	0.599" (15.2 mm)	1.25" (31.8 mm), 1.5" (38.1 mm), 2" (50.8 mm), 2.5" (63.5 mm)
STPW2	1 1/4" NPT	1.660" (42.2 mm)	1.380" (35.1 mm)	1.278" (32.5 mm)	1.160" (29.5 mm)	0.896" (22.8 mm)	2" (50.8 mm), 2.5" (63.5 mm)

\* Schedule 40 is standard. See options for other schedules.  
\*\* Bushing will be 304SS unless otherwise noted.

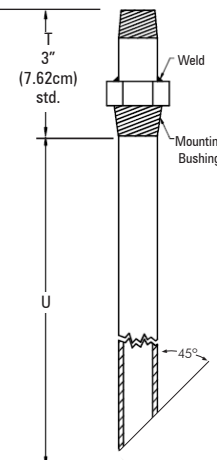

Select a designator for each component. There is a dash between each designator including options, i.e. SSST-12-R-2.25-R-E-B-1.5-300-RF. If not required leave blank.

SAMPLE PROBE							FLANGE			SAMPLE PROBE OPTIONS (see page 20)
<b>SST</b>	<b>12</b>	<b>R</b>	<b>2.25</b>	<b>R</b>	<b>E</b>	<b>B</b>	<b>1.5</b>	<b>300</b>	<b>RF</b>	
Type	U Length** (inches)	Material*	T Length (inches)	Root Dia. <b>Q</b>	Tip Dia. <b>D</b>	Bore*	Size (inches)	Rating	Type	

### THREADED - STRAIGHT

Type	Process NPT	Standard
		Tip Dia. <b>D</b> *
SSS	1/2"	0.680" (17.3 mm)
SSSO	3/4"	3/4" (19.1 mm)
SSS1	1"	7/8" (22.2 mm)
SSS2	1 1/4"	1 1/8" (28.6 mm)
SSS3	1 1/2"	1 1/8" (28.6 mm)

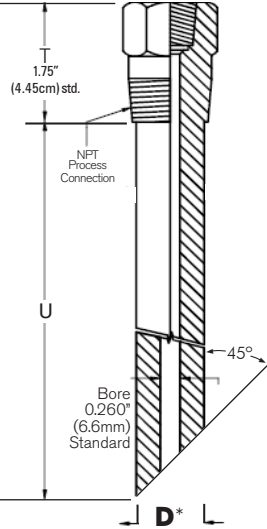

### FLANGED - STRAIGHT

Type	Description
SFS	Straight Flanged

FLANGE		
Size	Rating	Type
1"* (2.54 cm)	150	RF Raised Face
1.5" (3.81 cm)	200	FF Flat Face
2" (5.08 cm)	300	RTJ Ring Type Joint
3" (7.62 cm)	400	
4" (10.16 cm)	600	
	900	
	1500	

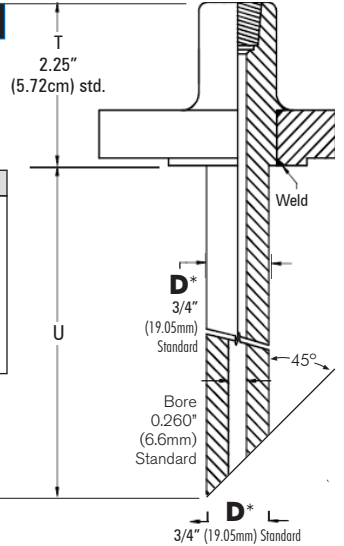

### THREADED - TAPERED

Type	NPT Process	Standard Dimensions	
		Root Dia. <b>Q</b> *	Tip Dia. <b>D</b> *
SST	1/2"	0.680" (17.3 mm)	5/8" (15.9 mm)
SST0	3/4"	7/8" (22.2 mm)	5/8" (15.9 mm)
SST1	1"	1 1/16" (26.0 mm)	5/8" (15.9 mm)
SST2	1 1/4"	1 1/8" (28.6 mm)	3/4" (19.1 mm)
SST3	1 1/2"	1 1/8" (28.6 mm)	3/4" (19.1 mm)

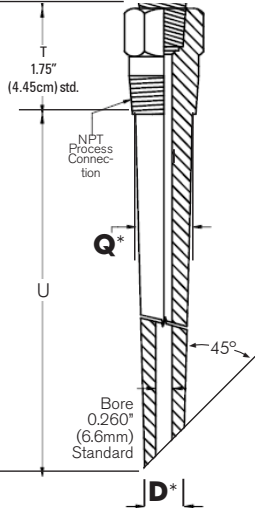

### FLANGED - TAPERED

Type	Description
SFT	Tapered Flanged

FLANGE		
Size	Rating	Type
1"* (2.54 cm)	150	RF Raised Face
1.5" (3.81 cm)	200	FF Flat Face
2" (5.08 cm)	300	RTJ Ring Type Joint
3" (7.62 cm)	400	
4" (10.16 cm)	600	
	900	
	1500	

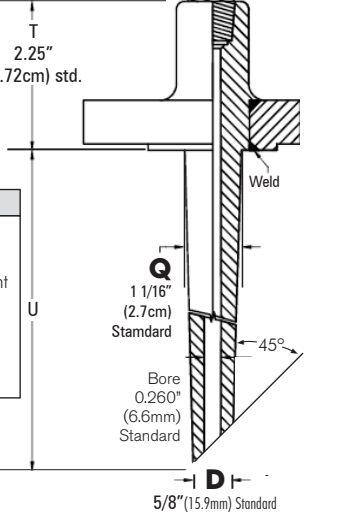

\* See page 20 for material, bore, root diameter and tip diameter selections.

# Temperature Sensors

# Thermowell and Sample Probe Options

OPTIONS	
Description	Designator
Brass Plug and Chain	BC
Certificate of Conformance	COC
Canadian Registration Number	CRN
Dye Penetration Testing	DP
Electropolish	EP
Full Penetration Weld	FP
Hydrostatic Pressure Test External	HTE
Hydrostatic Pressure Test Internal	HTI
1/4" NPT Instrument Connction	I1
1/2" NPSM Instrument Connection	I2
1/4" Compression threads Instrument Connection (includes nut and ferrule)	I3
MTR/Mill Certificate	MC
NACE Certification	NC
Oxygen Cleaned	OC
Radiographic Testing (X-Ray)	RT
Stainless Steel Plug and Chain	SC
Schedule 80 Pipewells	SH
Stellite® Coating	ST
Schedule 160 Pipewells	SX
Double Extra Heavy Pipewells	SXX
Tungsten Carbide	TC
Teflon® Coating	TF
Tantalum Sheath	TS
Ultra Sonic Flanged Weld Testing	UT
Velocity (Wake Frequency Calculations)	VC

SAMPLE PROBE OPTIONS	
Description	Designator
Bottom is straight, no 45° angle	M
Valve (specify brand, size and rating)	VO

MATERIAL LIST	
Description	Designator
Alloy 20	AA
Alloy 600	A
Hastelloy® B	B
F11 1 1/4%Cr - 1/2%Mo	BB
Hastelloy® C276	C
F22 2 1/4%Cr - 1%Mo	CC
321 Stainless Steel	D
F5 5%Cr - 1/2%Mo	DD
347 Stainless Steel	F
F9 9%Cr - 1%Mo	FF
Haynes HR160	GG
446 Stainless Steel	H
Haynes 230	HH
304H Stainless Steel	HP
316H Stainless Steel	HR
Alloy 800	I
F91 9%Cr - 1%Mo - 0.2%Vanadium	LL
304L Stainless Steel	LP
316L Stainless Steel	LR
Alloy 400 (Monel®)	M
Hastelloy® X	MM
Alloy 2200 (Nickel)	N
304 Stainless Steel	P
310 Stainless Steel	Q
316 Stainless Steel	R
Carbon Steel*	S
Super Duplex 2507	SD
Duplex 2205	SS
Stellite #6B	ST
Teflon®	T
Alloy 825	V
Alloy 601	W
Brass	Y
Other (specify)	Z

\*Threaded thermowell is 1018 CS, all others are CA105 CS.

TIP-D and Root-Q Diameter	
Inches	Designator
0.375	A
0.400	B
0.500	C
0.562	D
0.625	E
0.680	F
0.735	G
0.750	H
0.766	J
0.781	K
0.860	L
0.875	M
0.900	N
1.000	P
1.050	Q
1.063	R
1.125	S
1.250	T
1.315	U
1.375	V
1.500	W
1.625	Y
1.900	Z
Other (specify)	X

Bore Diameter	
Inches	Designator
0.128	A
0.260*	B
0.385**	C
0.406	D
0.515	E
0.656	F
0.718	G
Other (specify)	X

\*standard for 1/4" probes  
 \*\*standard for 3/8" probes  
 Consult factory for other bore sizes.

# Temperature Sensors

## High Temperature Unprotected Thermocouple & Protection Tubes

### Mullite and Alumina Tubes

**Alumina tubes** are 98% pure alumina oxide and can be used with all thermocouple calibrations including noble metals. Good general purpose use. Use for all atmospheres with temperature rating of 3400°F (1,871°C). Has fair resistance to thermal shock.

**Mullite** is preferred for oxidizing atmospheres and can not be used with noble metal thermocouples. Maximum temperature rating is 3000°F (1,648°C). Both Mullite and Alumina should be heated prior to process insertion.

### Hexoloy® Tubes

Excellent abrasion resistance and high resistance to thermal shock, also has good thermal conductivity (3 times greater than stainless steel). Due to its toughness it can be used in high pressure and velocity environments. Maximum temperature rating is 2900°F (1,593°C).

Select a designator for each component. There is a dash between each designator including options, i.e. CI-NU-6-CP1-18-A-1.5-K-316-G-A (with cable). If not required leave blank.

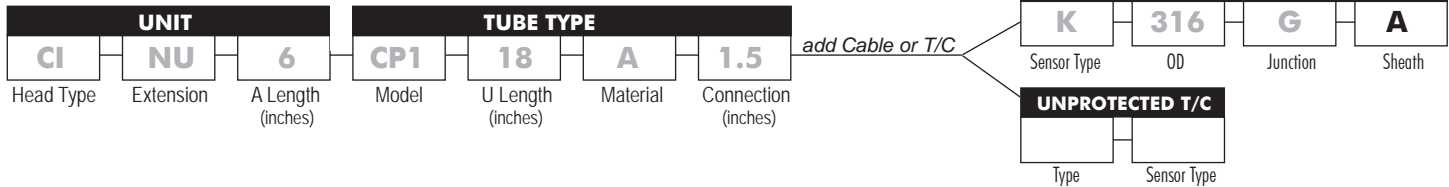

UNIT	
<b>HEAD TYPE</b>	
0	No Head
CA	Cast Aluminum
CI	Cast Iron
CSS	Cast Stainless Steel
PPS	Polypropylene Sanitary
FTA	Flip Top Aluminum
FTP	Flip Top Poly (white)
EPA	Explosion Proof Aluminum
EPS	Explosion Proof Stainless Steel
EHA	Explosion Proof Aluminum
EHI	Explosion Proof Iron

See page 24-25 for more details.

#### EXTENSION

0	None
NU	Nipple/Union Galvanized
NUS	Nipple/Union Stainless Steel

See page 26 for more options.

#### TUBE TYPE

Model	ID	OD	PROCESS CONNECTIONS				
			NPT (inches)				
			0.5	0.75	1	1.25	1.5
Mullite and Alumina							
CP1	0.250" (6.4 mm)	0.375" (9.5 mm)	X	X	X	X	X
CP2	0.437" (11.1 mm)	0.687" (17.5 mm)		X	X	X	X
CP3	0.625" (15.9 mm)	0.875" (22.2 mm)			X	X	X
Hexoloy®* Hexoloy® w/Alumina							
CP5	0.250" (6.4 mm)	0.375" (9.5 mm)	X	X	X	X	X
CP6	0.375" (9.5 mm)	0.625" (15.9 mm)		X	X	X	X
CP7	0.500" (12.7 mm)	0.750" (19.1 mm)			X	X	X
CP8	0.500" (12.7 mm)	1.00" (25.4 mm)				X	X
CP9	0.750" (19.1 mm)	1.250" (31.8 mm)				X	X

#### STANDARD LENGTHS (U)

- 12" (30.48 cm)
- 18" (45.72 cm)
- 24" (60.76 cm)
- 30" (76.2 cm)
- 36" (91.44 cm)

#### TUBE MATERIALS

- A Alumina
- M Mullite
- HX Hexoloy®\*
- HA Hexoloy® w/Alumina Inner Tube (Plat TC)

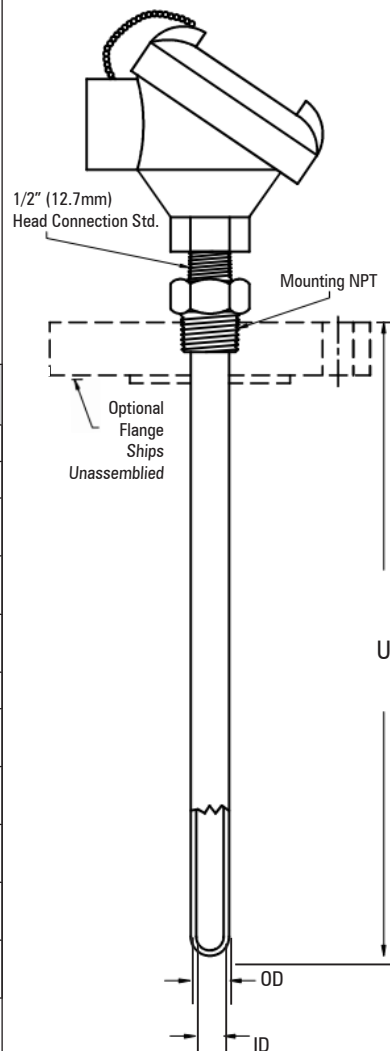

#### MI CABLE

##### SENSOR TYPE

K	Chromel® Alumel®
N	Nicrosil® Nisil®
R	Platinum / 13% Rhodium
S	Pure Platinum
	Platinum / 10% Rhodium
	Pure Platinum
B	Platinum / 30% Rhodium
	Platinum / 6% Rhodium

For special limits on thermocouples, repeat sensor type, i.e. KK.

##### OD

316	3/16" (4.8 mm)
14	1/4" (6.4 mm)
516	5/16" (7.9 mm)
38	3/8" (9.5 mm)

##### JUNCTION

G	Grounded
U	Ungrounded
E	Exposed
DG	Dual Grounded
DU	Dual Ungrounded

##### SHEATH MATERIALS

A	Alloy 600
---	-----------

#### UNPROTECTED THERMOCOUPLE

Model	Diameter		Wire Gauge	Sensor Type
	Single	Dual		
10	0.150" (3.8 mm)		20	K
15		0.187" (4.9 mm)	20	K
20	0.250" (6.4 mm)		14	K
25		0.313" (8.0 mm)	14	K
30	0.500" (12.7 mm)		8	K
35		0.550" (13.9 mm)	8	K
40	0.153" (3.9 mm)		24	R & S
45		0.197" (5.0 mm)	24	R & S

# Temperature Sensors

## Sensor and Transmitter Options

SENSOR OPTIONS*	
Description	Designator
Armor (Stainless Steel)	A
Armor with PVC Jacket (Black)	AP
Armor with Teflon® Jacket (White)	AT
Bayonet Adapter (Adjustable) ADJ. 1/8" (3.2 mm) OD only	BA
Bayonet Cap on Armor	BCA
45° Bend in Sheath (specify length from bend to tip)	BD45
90° bend in Sheath (specify length from bend to tip)	BD90
Bayonet Cap & Spring, 1/8" (3.2 mm) and 3/16" (4.8 mm) OD only. (specify length from bottom of cap to tip)	BF
ADJ. Brass Compression Fitting 1/8" NPT	BR18
ADJ. Brass Compression Fitting 1/4" NPT	BR14
ADJ. Brass Compression Fitting 1/2" NPT	BR12
Bell Spring Transition Relief	BS
Weather Tight Fitting Leads Only 1/2" NPT	CG12
Compensated Terminals (EHA/EHI head only)	CT
Connector with Epoxy Sealed Screws	CV
Double Ended Hex Fitting, 1/2" NPT Spring Loaded	DE12
Expansion Loop Type 1510, 1520	EL
Four Wire Element RTD	FW
Class A Tolerance Per DIN EN 60751 RTD	GA
High Accuracy RTD (Low Temperature only)	HA
Heat Shield Type 1510, 1520	HS
High Temperature Potting [Service over 300°F (148.89°C) max temperature 1550°F (843.33°C)]	HTP
High Vibration (PM RTDs only)	HV
Pad Radius for NPT Pipe Sizes 6" and Above Type 1500	L
Connector "L" Bracket For M.I. Cable	LB
Large Jack - J, K, T, E, R/S CU (When Purchased With Plug)	LJ
Pad Radius for NPT Pipe Sizes 3 - 6" Type 1500	M
Miniature Jack - J, K, T, E, R/S CU (When Purchased With Plug)	MJ

\* Not all options are available on all models, consult factory.

NOTE: If more than one option per sensor is needed place a dash (-) between each option ordered, i.e. -A-CG12 (armor with weathertight fitting)

SENSOR OPTIONS*	
Description	Designator
No Transition (Sheath length is over all length)	NT
Plastic Melt Bolts - Machined of Solid 304SS Bar 1/2-20 UNF Threads, Standard Lengths "L" 3" (7.62 cm), 4" (10.16 cm), 6" (15.24 cm), 8" (20.32 cm), 10" (25.4 cm) and 12" (30.48 cm)	PMB
Spring Assembly	SA
Spring Assembly with Hex Fitting 1/2" NPT 304SS	SA12
Stainless Steel Overbraid on Lead Wire	SB
Single Ended Fixed Hex Fitting 1/2" NPT 304SS	SE12
Single Ended Fixed Hex Fitting 1/4" NPT 304SS	SE14
Single Ended Fixed Hex Fitting 1/8" NPT 304SS	SE18
ADJ. SS Compression Fitting 1/8" NPT	SS18
ADJ. SS Compression Fitting 1/4" NPT	SS14
ADJ. SS Compression Fitting 1/2" NPT	SS12
Smooth Transition	ST
Teflon® Ferrule for SS or BR Adjustable Fitting (i.e. SST12)	T
Tube on Armor, 1/4" (6.4 mm) OD x 2" (50.8 mm) long	TA
Tube on Armor with SS12 Fitting for Head Mount	TAC
Tinned Ends (Multistranded wire only)	TE
Teflon® Coated Sheath	TF
Two Wire Element RTD	TW
Vent Hole in Compression Fitting	VH
Wire Clamp Bracket For Leads	WC
Weld Pad, 1" (2.54 cm) x 1" (2.54 cm) x 1/8" (0.32 cm) SS	WP
Wire Wound RTD Element	WW
TRANSMITTER OPTIONS	
Hart® Compatible	HC
Programmable, RTD, FM	LCP
Programmable Type	PT

# Temperature Sensors

## Sensor and Transmitter Options



A - Armor (Stainless Steel)



AP - Armor with PVC



BA - Bayonet Adapter



BCA - Bayonet Cap on Armor



BF - Bayonet Cap and Spring



BPI - Battery Powered LCD



BPIX - Battery Powered Indicator Explosion Proof

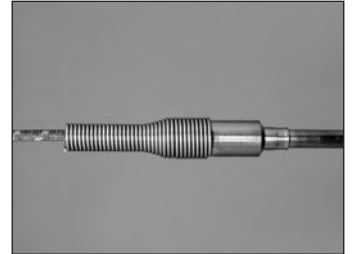

BS - Bell Spring Transition Relief

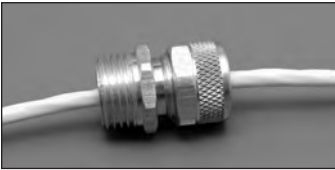

CG12 - Weather Tight Fitting



DE12 - Double Ended Hex Fitting  
1/2" NPT Spring Loaded Stainless Steel



EB - Reducer Bushing for Head Conduit 3/4" to 1/2" NPT

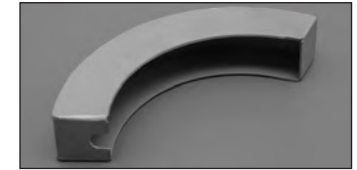

HS - Heat Shield for Type 1510 and 1520



LB - Connector "L" Bracket



PMB - Plastic Melt Bolt



SA12 - Spring Assembly with Hex Fitting Stainless Steel



SB - Overbraid Stainless Steel



Thermowell Plug and Chain  
SC - Stainless Steel  
BC - Brass



Single End Hex Fitting Stainless Steel (SE12, SE14, SE18)



ST - Smooth Transition  
Red mark denotes start of transition, do not install compression fitting above red mark



TA - Tube on Armor



TAC - Tube on Armor with SS12 Fitting



WP - Weld Pad



Adjustable Compression Fitting (BR18, BR14, BR12, SS18, SS14, SS12; shown is 1/2" NPT SS)

## Universal Heads – Standard



**Designator** CA – Cast Aluminum - NEMA 4X  
CI – Cast Iron

These standard universal heads are available in polished Cast Aluminum and rugged Cast Iron. The heads are threaded and come standard with a heavy duty silicone gasket to protect against wind blown rain and dust. The gasket provides an excellent weather tight seal and meets NEMA 4X rating. Its universal construction accepts DIN size hockey puck temperature transmitters and any terminal block up to 2 inches (5.08 cm) in diameter. Standard openings are 1/2 inch NPT instrument and 3/4 inch NPT conduit. A stainless steel chain which connects the cap to the body is supplied with each head.

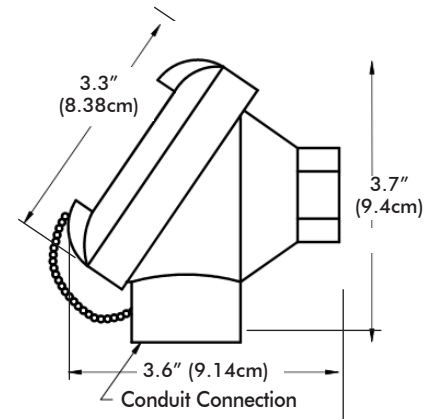

## General Purpose Stainless Steel



**Designator** CSS – Cast Stainless Steel

This head has all the same characteristics as our Universal Explosion Proof stainless steel head except it has no agency approvals for use in hazardous locations. It is very effective in food processing areas where other metal heads may be affected by caustic washdowns and other CIP procedures. It is also very cost effective in process areas where aluminum can't be used.

Standard openings are 1/2 inch NPT instrument and 3/4 inch NPT conduit.

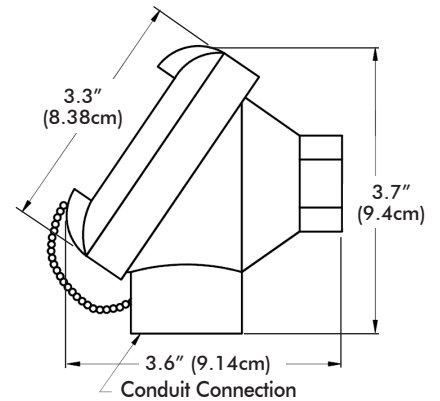

## Universal Explosion Proof Heads – Standard



**Designator** EPA - Explosion Proof Aluminum - NEMA 4X, IP68  
EPS - Explosion Proof Cast Stainless Steel - NEMA 4X, IP68

Head housings are available in both cast aluminum and 316 stainless steel. The heads are threaded and can accept DIN size hockey puck temperature transmitters and slightly larger sized transmitters and any terminal block up to 2 inches (5.08 cm) in diameter. The heads carry CSA, FM, ATEX and IECEx approvals. FM explosion proof rating allows the head to be used in class I, Division 1, Groups B,C, & D and Class II, Division 1, Groups E,F & G areas. Heads are also rated for NEMA 4X and IP68. Standard openings are 1/2 inch NPT instrument and 3/4 inch NPT conduit.

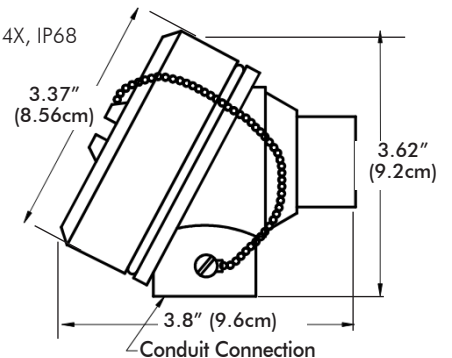

## Large Universal Explosion Proof Heads



**Designator** EHA – Explosion Proof Aluminum  
EHI – Explosion Proof Cast Iron

When space is not a problem this over sized, tough head is the answer. This head has all the standard features of our Universal Explosion Proof heads. Its size can accept even larger terminal blocks. The large cavity promotes faster field wiring connections and consequently reduces installation costs. To reduce errors and improve accuracy these heads can accept the TB200 terminal block. This block is available with thermocouple contacts. Standard openings are 1/2 inch NPT instrument and 3/4 inch NPT conduit.

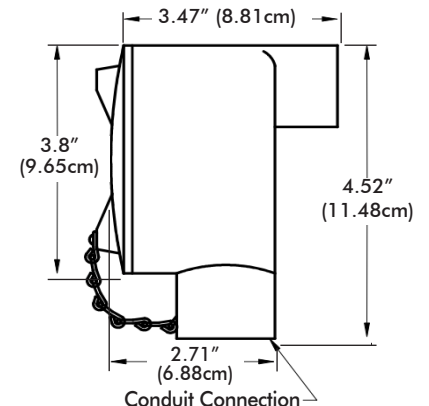



## Flip Top Aluminum



**Designator** FTA – Flip Top Aluminum - IP68

This Cast Aluminum head has no threads, therefore galling (caused by excessive heat and chemical attack) is eliminated. Thread galling may require tools to force the cap open. With the Flip Top design no tools are ever needed to open the cap and inspect or replace the sensor. Stainless hinge hardware and an O ring are standard. The head is rated for IP68 and accepts DIN size hockey puck temperature transmitters and any terminal block up to 2 inches (5.08 cm) in diameter. The cost effective aluminum design is replacing conventional threaded heads in many process plants. Standard openings are 1/2 inch NPT instrument and 3/4 inch NPT conduit.

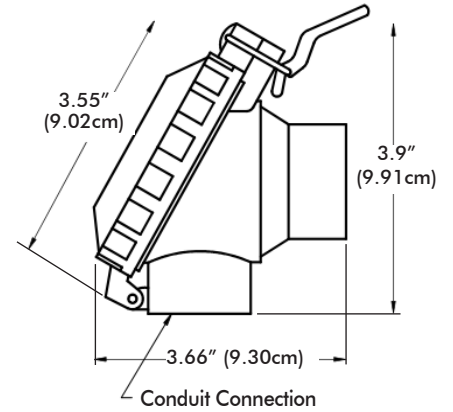

## Flip Top Sanitary Head



**Designator** FTP – White Flip Top Sanitary

This FDA approved plastic sanitary head has the same specifications as the FTA (flip top aluminum) head. It is NEMA 4 rated and accepts standard terminal blocks. Due to the added RFI protection a metal head provides this head is not recommended as a housing for field mounted temperature transmitters. The absence of threads in the cap and body and the FDA approved material make this head an excellent choice in food processing applications, especially where CIP caustic wash downs are used. Standard openings are 1/2 inch NPT instrument and 3/4 inch NPT conduit. Does not accommodate transmitter.

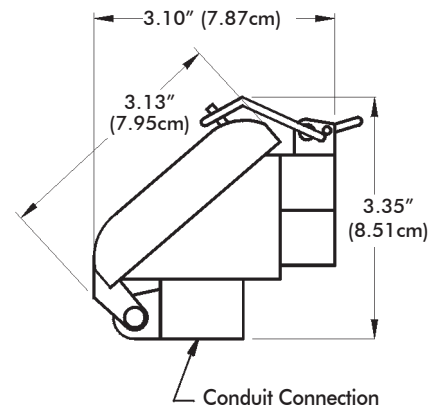

## Plastic Heads



**Designator** PPS – White Polypropylene Sanitary

These high density plastic heads are extremely suitable for conditions that would attack conventional metal housings. The screw cover heads come standard with a neoprene rubber gasket and stainless steel chains and screws. Standard openings are 1/2 inch NPT instrument and 3/4 inch NPT conduit. Due to the added RFI protection a metal head provides this head is not recommended as a housing for field mounted temperature transmitters.

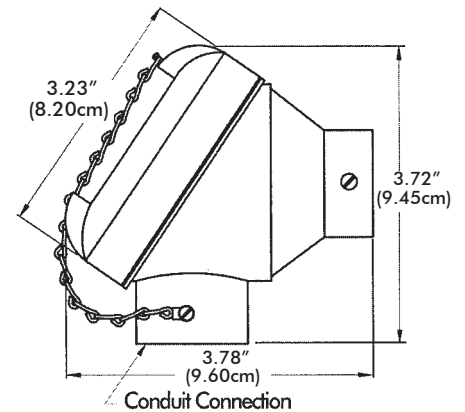

## Terminal Blocks

Our ceramic terminal block fits all special purpose and general purpose heads. It is easily field configurable for single or dual sensor applications and can be used with either thermocouples or RTDs. Its ceramic base protects against elevated temperatures and the brass contacts make it easy for field wiring. The compensated block used in EHA and EHI explosion proof heads is available with thermocouple contacts.

### Ceramic Block



#### Designator

TB102 - Ceramic Block - Single TC  
 TB103 - Ceramic Block - Single RTD  
 TB104 - Ceramic Block - Dual TC  
 TB106 - Ceramic Block - Dual RTD

### Compensated Block for EHA and EHI Heads

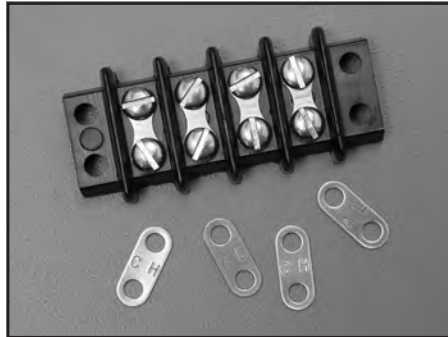

#### Designator

TB202 - Block - Single TC  
 TB203 - Block - Single RTD  
 TB204 - Block - Dual TC  
 TB206 - Block - Dual RTD

### Compression Block for EHA, EHI, EP Series

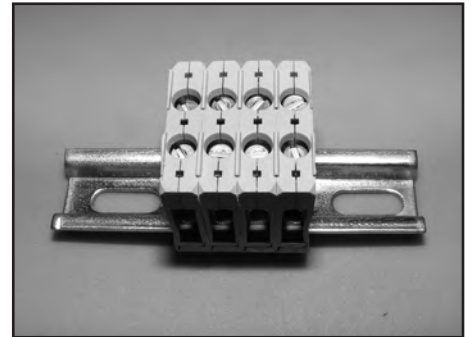

#### Designator

CB102 - Block - Single TC  
 CB103 - Block - Single RTD  
 CB104 - Block - Dual TC  
 CB106 - Block - Dual RTD

Note: For thermocouple contacts insert calibration letter following block part number. This block can be used in a junction box and is available in a one piece construction with up to 20 points. To order follow the ordering sequence above. i.e. TB220-J is a single terminal block with 20 points for an Iron Constantan® thermocouple.

## Extensions

Nipples and unions are constructed of galvanized carbon steel as a standard construction. Adding an S to the end of the order code gets you a corrosion resistant stainless steel extension. Standard extension size is 1/2" NPT.

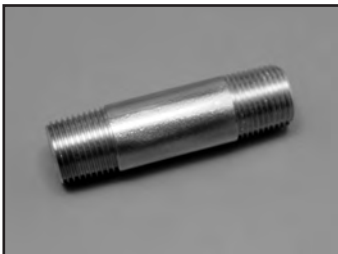

#### Designator

N Nipple  
 NS Nipple - Stainless Steel

#### Length

1" (2.54 cm) Minimum



#### Designator

NU Nipple/Union  
 NUS Nipple/Union - Stainless Steel

#### Length

2" (5.08 cm) Minimum



#### Designator

NUN Nipple/Union/Nipple  
 NUNS Nipple/Union/Nipple - Stainless Steel  
 PNUN Pressure Seal in Union - Galvanized  
 PNUNS Pressure Seal in Union - Stainless Steel

#### Length

3" (7.62 cm) Minimum



#### Designator

HUNS Hex Nipple/Union/Nipple Stainless Steel

#### Length

3" (7.62 cm) Minimum

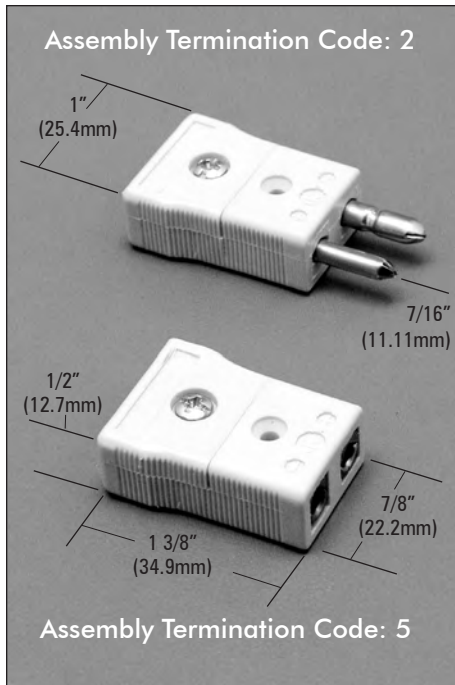

## Thermocouple Connector – Two Pole

- Glass filled thermoplastic body provides high strength at temperatures up to 425°F (218°C) as well as low moisture absorption and good dielectric constant.
- Heavy duty hollow pin construction prevents reverse mating of polarity.\*
- Body color coded to ISA and ANSI standards.
- Polarity indicated by symbols molded into body.
- Contacts made of thermocouple materials which meet ISA and ANSI standards.
- Jack spring loaded to insure firm grip to plug.
- Accepts wire sizes to 14 awg.
- Single screw cover cap for fast assembly.
- Accepts crimp and tube adapter for product from 0.020" (0.5 mm) to 0.375" (9.5 mm).
- Finger grips to permit ease of connection.
- Quick wiring hook up with large head screws and wire channel.

Designator		Thermocouple Type	Body Color	Actual Alloy	
Plugs	Jacks			+ In Connector	-
LP-J	L J-J	Iron-Constantan®	Black	Iron	Constantan®
LP-K	L J-K	Chromel®-Alumel®	Yellow	Chromel®	Alumel®
LP-E	L J-E	Chromel®-Constantan®	Violet	Chromel®	Constantan®
LP-T	L J-T	Copper-Constantan®	Blue	Copper	Constantan®
LP-R/S	L J-R/S	Platinum/Rhodium-Platinum	Green	Copper	#11 Alloy
LP-CU	L J-CU	Uncompensated	White	Copper	Copper

\* Solid pin available on above construction. Add S to Part No. (i.e. LPS-J)

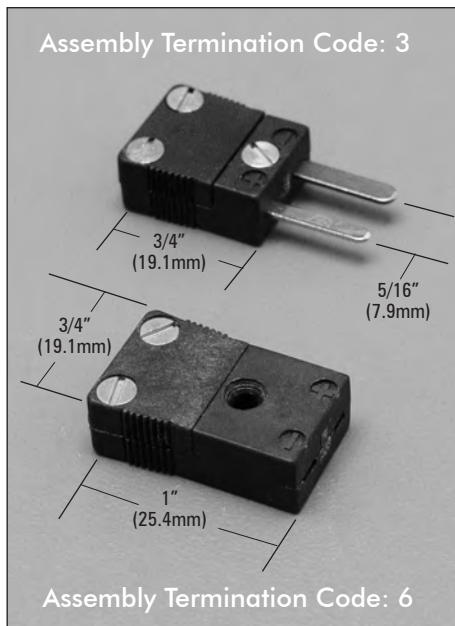

## Miniature Thermocouple Connector

- Thermoplastic body provides high strength at temperatures up to 425°F (218°C) as well as low moisture absorption and good dielectric constant.
- Small, light weight and space saving.
- Body color coded to ISA and ANSI standards.
- Polarity indicated by symbols molded into body.
- Contacts made of thermocouple materials which meet ISA and ANSI standards .
- Jack spring loaded to insure firm grip to plug.
- Accepts crimp adapter for product from 0.020" (0.5 mm) to 0.125" (3.2 mm).
- Finger grips to permit ease of connection.
- 0.10" (2.54 mm) I.D. center mounting hole.

Designator		Thermocouple Type	Body Color	Actual Alloy	
Plugs	Jacks			+ In Connector	-
M P-J	M J -J	Iron-Constantan®	Black	Iron	Constantan®
M P- K	M J - K	Chromel®-Alumel®	Yellow	Chromel®	Alumel®
M P- E	M J - E	Chromel®-Constantan®	Violet	Chromel®	Constantan®
M P-T	M J -T	Copper-Constantan®	Blue	Copper	Constantan®
M P- R / S	M J -R / S	Platinum/Rhodium-Platinum	Green	Copper	#11 Alloy
M P- C U	M J -C U	Uncompensated	White	Copper	Copper

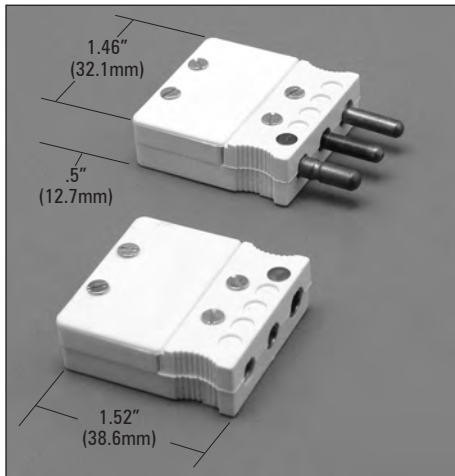

### Three Pin Plugs and Jacks

- Body color coded to ISA and ANSI standards.
- Polarity marked.
- Negative lead clearly indicated with red disk.
- Knurled finger grip.
- Shatterproof plastic
- Temperature rating of 300°F (149°C)

Designator		Thermocouple Type	Body Color	Actual Alloy + In Connector -		Ground
Plugs	Jacks					
TPP-J	TPJ-J	Iron-Constantan®	Black	Iron	Constantan®	Copper
TPP-K	TPJ-K	Chromel®-Alumel®	Yellow	Chromel®	Alumel®	Copper
TPP-E	TPJ-E	Chromel®-Constantan®	Violet	Chromel®	Constantan®	Copper
TPP-T	TPJ-T	Copper-Constantan®	Blue	Copper	Constantan®	Copper
TPP-CU	TPJ-CU	Uncompensated	White	Copper	Copper	Copper

### Accessories



#### Thermocouple Alloy Spade Lugs

Sold in bags of 25 each conductor.

**Designator** SL - \_\_\_\_\_  
(thermocouple calibration)  
Example: SL-K



#### L Bracket

For installing single metal sheath thermocouple to connector. Mounts to underside of connector for ease of wiring connections. Two screws provided for easy attachment to thermocouples.

**Designator** LB - \_\_\_\_\_  
(Sheath OD) Example: LB-1/8"  
(3.2 mm)



#### Wire Clamp Bracket

Rugged bracket for strain relieving insulated wires. Easily installed after wires are attached to connector.

**Designator** WC



#### Miniature Wire Clamp Bracket

Smaller version of wire clamp bracket (above). Easily installed after wires are attached to connector.

**Designator** MWC



#### Weather Proof Jackets

Neoprene rubber jackets adds moisture protection to connection. Two per assembly.

**Designator** WPJ

#### Pipe Clamp Adapter

Used to measure any cylindrical surface up to 36" (91.44 cm). Type PC accepts any 1100 or 1200 thermocouple with either a fixed BF or adjustable BA bayonet adapter. Be sure to add insulation thickness, if any, to overall length of thermocouple.

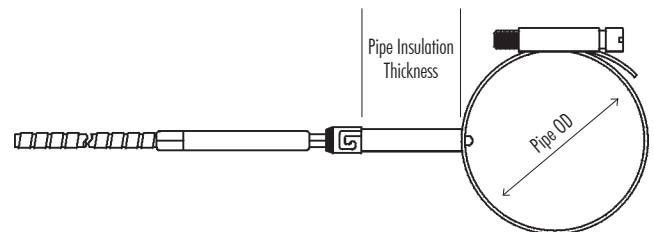

Select a designator for each component. There is a dash between each designator, i.e. PC-5-1.5.

PIP CLAMP ADAPTER		
<b>PC</b>	<b>5</b>	<b>1.5</b>
	Pipe Size (inches)	Pipe Insulation Thickness (inches) (minimum dimension 1.5" - 38.1 mm)

# Temperature Sensors

## Thermocouple Extension Wire

**Color Coding:** ANSI

**Multi Strand:** 16 gauge - 7 strands of 24 gage  
20 gauge - 7 strands of 28 gage

**Accuracy:** Per ANSI MC 96.1 and ASTM E230

**To Order:** Specify the type number and calibration from the table below.

Example: 920-KM is fiberglass insulated and jacketed 20 gage, Chromel® Alumel® multistranded.



Type	Insulation/Jacket	Gage	Available Calibrations	Temp Rating	Construction
U716	PVC/PVC	16 Solid	JX, KX, TX, EX	221°F (105° C)	Each conductor is twisted and shielded with a drain wire added within the twist of lay. A 221°F (105°C) flame retardant PVC jacket is then applied. This construction is UL approved as 300 volt PLTC and has passed the IEEE 383 vertical flame test.
U720	PVC/PVC	20 Solid	JX, KX, TX, EX	221°F (105° C)	
720	PVC/PVC	20 Solid 20 Stranded	JX, KX, TX, EX, RX, SX JXM, KXM	221°F (105°C)	Conductors are laid parallel and jacketed. The thermocouple grade calibrations are available in both solid and multistrand. PVC has good moisture and abrasion resistance but becomes brittle at low temperatures, usually below minus 15°F (-26.1°C).
820	FEP/FEP (Teflon®)	20 Solid 20 Stranded	J, K, T JM, KM	400°F (204°C)	Conductors are laid parallel and jacketed. Teflon® has excellent resistance to moisture in temperatures down to minus 90°F (-67.8°C). This fluoropolymer has been used in many food grade applications.
824	FEP/FEP (Teflon®)	24 Solid	J, K, T	400°F (204°C)	
920	Fiberglass/Fiberglass	20 Solid 20 Stranded	J, K, T, E, RX, SX JM, KM	950°F (510°C)	Conductors are laid parallel and jacketed. Fiberglass has poor resistance to moisture and only fair abrasion resistance. A saturant is applied to facilitate easy stripping and to prevent the fiberglass from fraying.

### Thermocouple Type

Wire Alloys	ANSI Symbol	Temperature Range		Standard Limits
		°F	°C	
Iron vs. Constantan®	J	32° to 545°	0° to +285°	±4°F (±2.22°C)
		545° to 1400°	286° to 760°	±0.75%
Chromel® vs. Alumel®	K	-165° to 32°	-109.4° to 0°	±4°F (±2.22°C)
		32° to 545°	0° to 285°	±4°F (±2.22°C)
		545° to 2300°	285° to +1260°	±0.75%
Copper vs. Constantan®	T	-330° to -85°	-201° to -65°	±1.5%
		-85° to 270°	-65° to 132°	±1.8° (±1°C)
		270° to 660°	132° to 348°	±0.75%
Chromel® vs. Constantan®	E	-330° to -270°	-201° to -167°	±1%
		-270° to 480°	-167° to -248°	±3°F (±1.67°C)
		480° to 640°	248° to 337°	±3°F (±1.67°C)
		640° to 1600°	337° to 871°	±0.5%

### ANSI Color Code for Thermocouple Wire

ANSI Symbol	Wire Alloys	Polarity	Thermocouple Wire Color		T/C Extension Wire Color	
			Individual	Jacket	Individual	Jacket
J	Iron	+JP	White	Brown	White	Black
	Constantan®	-JN	Red		Red	
K	Chromel®	+KP	Yellow	Brown	Yellow	Yellow
	Alumel®	-KN	Red		Red	
T	Copper	+TP	Blue	Brown	Blue	Blue
	Constantan®	-JN	Red		Red	
E	Chromel®	+EP	Purple	Brown	Purple	Purple
	Constantan®	-EN	Red		Red	

### Thermocouple Extension Wire

Extension Wire Alloys	ANSI Symbol	Temperature Range		Standard Limits
		°F	°C	
Iron vs. Constantan®	JX	32° to 400°	0° to 204°	±4°F (±2.22°C)
Chromel® vs. Alumel®	KX	32° to 400°	0° to 204°	±4°F (±2.22°C)
Copper vs. Constantan®	TX	-75° to 210°	-59° to 98°	±1°F (±0.56°C)
Chromel® vs. Constantan®	EX	32° to 400°	0° to 204°	±3°F (±1.67°C)

**Programmable Type PT** Type PT is a universal, isolated, temperature transmitter with additional voltage and resistance input. Its robust design and high quality gives excellent performance and accuracy also under harsh conditions.



- High accuracy and long term stability
- 50-point Customized Linearization and Callendar-Van Dusen
- Accepts RTD, T/C, mV and  $\Omega$
- Sensor error and system (sensor/transmitter) error correction for highest total accuracy
- Low temperature drift
- Configuration via USB or NFC without external power, or bluetooth via an optional dangle
- Runtime counter - hour counter for elapsed operational time
- Rugged design tested for 10 g vibrations
- High security - Password protection and date of changes logged
- 5 Year Warranty
- NAMUR compliant
- FM and IECEx approval, ATEX optional

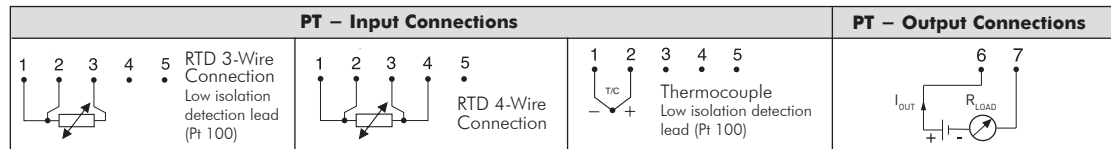

SPECIFICATIONS	Type PT
<b>Input RTD</b>	3-, 4-wire connection
Pt100 ( $\alpha = 0.00385$ )	-200 to +850 °C / -328 to +1562 °F
PtX $10 \leq X \leq 1000$ ( $\alpha = 0.00385$ )	Upper range depending on X-value
Pt100 ( $\alpha = 0.003916$ )	-200 to +850 °C / -328 to +1562 °F
Ni100 <sup>1)</sup> , Ni120 <sup>2)</sup>	-60 to +250 °C / -76 to +482 °F
Ni1000 <sup>1)</sup>	-50 to +180 °C / -58 to +356 °F
Cu10 <sup>3)</sup>	-50 to +200 °C / -58 to +392 °F
<b>Input Resistance / potentiometer</b>	0 to 10000 $\Omega$ / 100 to 10000 $\Omega$
<b>Input Thermocouples</b>	Types B, C, D, E, J, K, N, R, S, T
<b>Input mV</b>	-10 to +1000 mV
<b>Sensor failure</b>	Upscale ( $\geq 21.0$ mA) or downscale ( $\leq 3.6$ mA) action
<b>Adjustments – Zero</b>	Any value within range limits
<b>Adjustments – Minimum spans</b>	
Pt100, Pt1000, Ni100, Ni1000	10 °C / 18 °F
Potentiometer	10 $\Omega$
T/C, mV	2 mV
<b>Output</b>	4-20 / 20-4 mA, temperature linear
<b>Operating temperature</b>	-40 to +85 °C / -40 to +185 °F
<b>Galvanic isolation</b>	1500 VAC, 1 min
<b>Power supply C</b>	8.0...30.0 VDC
<b>Intrinsic safety</b>	
IPAQ C330X cFMus	IS CL I Div 1 GP A-D, T6...T4 CI I Zn 0 AEx/Ex ia IIC T6...T4 Ga4)
<b>Typical accuracy</b>	$\pm 0.08^\circ\text{C}$ or $\pm 0.08\%$ of span
<b>Connection head</b>	DIN B or larger

\* Consult factory for other RTDs Note: <sup>1</sup>DIN 43760 <sup>2</sup>Edison No. 7 <sup>3</sup>Edison No. 15

Select a designator for each component. There is a dash between each designator including options, i.e. PT-0-200°F-J-0-FC-FW. If not required leave blank.

- For factory configuration specify option FC.
- The transmitter will be programmed for the specified range and sensor type.
- The user can not change the programmed features without the factory supplied communications cable.
- To order the communications cable (only one on the PT required regardless of the number of transmitters) specify part number 70CFGUS101.

TRANSMITTER						
PT	0-200°F	J	0		FC-FW	
Model	Range	Sensor Input	Head*		Options	
PT	Specify in F or C	J, K, N, E, T, R, S,	0	No Head	EPA	Explosion Proof Aluminum
HC	i.e. 0-200°F	Pt 100	CA	Cast Aluminum	EPS	Explosion Proof Stainless Steel
		Pt 1000	CI	Cast Iron	EHA	Explosion Proof Aluminum
			CSS	Cast Stainless Steel	EHI	Explosion Proof Iron
			FTA	Flip Top Aluminum		
					FC	Factory Configured
					FW	Four Wire RTD
					LPI	Loop Powered Indicator
					CC	Communications Cable
						(required to configure PT)

\* See page 24-25 for more details.

## Hart® Programmable Type HC

Type HC is a modern, HART® temperature transmitter developed to meet the highest standards of accuracy and reliability. A universal transmitter compatible with RTD, thermocouples, voltage and potentiometer sensors. It is fully compatible with HART® 7 and offers extended diagnostic information, for example device error, sensor and wiring conditions.



- High accuracy and long term stability
- Accepts RTD, T/C, mV and ohm
- Sensor error and system (sensor/transmitter) error correction
- 50-point Customized Linearization and Callendar-Van Dusen
- Rugged design tested for 10 g vibrations



- Configuration via USB or NFC without external power, or bluetooth via an optional dangle
- Runtime counter - hour counter for elapsed operational time
- Communicates with HART Communicator or PC via modem
- 5 Year Warranty
- NAMUR compliant
- FM and IECEx approval, ATEX optional

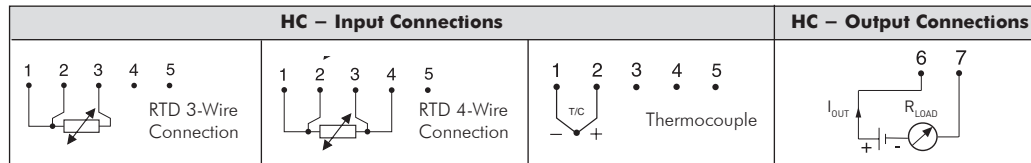

SPECIFICATIONS	Type HC
<b>Input RTD</b>	3-, 4-wire connection
Pt100 ( $\alpha = 0.00385$ )	-200 to +850 °C / -328 to +1562 °F
PtX $10 \leq X \leq 1000$ ( $\alpha = 0.00385$ )	Upper range depending on X-value
Pt100 ( $\alpha = 0.003916$ )	-200 to +850 °C / -328 to +1562 °F
Ni100 <sup>1)</sup> , Ni120 <sup>2)</sup>	-60 to +250 °C / -76 to +482 °F
Ni1000 <sup>1)</sup>	-50 to +180 °C / -58 to +356 °F
Cu10 <sup>3)</sup>	-50 to +200 °C / -58 to +392 °F
<b>Input Resistance / potentiometer</b>	0 to 10000 $\Omega$ / 100 to 10000 $\Omega$
<b>Input Thermocouples</b>	Types B, C, D, E, J, K, N, R, S, T
<b>Input mV</b>	-10 to +1000 mV
<b>Sensor failure</b>	Upscale ( $\geq 21.0$ mA) or downscale ( $\leq 3.6$ mA) action
<b>Adjustments – Zero</b>	Any value within range limits
<b>Adjustments – Minimum spans</b>	
Pt100, Pt1000, Ni100, Ni1000	10 °C / 18 °F
Potentiometer	100 $\Omega$
T/C, mV	2 mV
<b>Output</b>	4-20 / 20-4 mA, temperature linear
<b>Operating temperature</b>	-40 to +85 °C / -40 to +185 °F
<b>Galvanic isolation</b>	1500 VAC, 1 min
<b>Power supply</b>	8.5...30.0 VDC
<b>Intrinsic safety</b>	
IPAQ C330X cFMus	IS CL I Div 1 GP A-D, T6...T4 CI I Zn 0 AEx/Ex ia IIC T6...T4 Ga4)
<b>Typical accuracy</b>	$\pm 0.08^\circ\text{C}$ or $\pm 0.08\%$ of span
<b>Connection head</b>	DIN B or larger

\* Consult factory for other RTDs Note: <sup>1</sup>DIN 43760 <sup>2</sup>Edison No. 7 <sup>3</sup>Edison No. 15

Select a designator for each component. There is a dash between each designator including options, i.e. HC-0-200°F-J-0-FC-FW. If not required leave blank.

- For factory configuration specify option FC.
- The transmitter will be programmed for the specified range and sensor type.
- The user can not change the programmed features without the factory supplied communications cable.
- To order the communications cable (only one on the HC required regardless of the number of transmitters) specify part number 70CFGUS101.

TRANSMITTER						
HC	0-200°F	J	0		FC-FW	
Model	Range	Sensor Input	Head*		Options	
PT HC	Specify in F or C i.e. 0-200°F	J, K, N, E, T, R, S, Pt 100 Pt 1000	0 No Head CA Cast Aluminum CI Cast Iron CSS Cast Stainless Steel FTA Flip Top Aluminum	EPA Explosion Proof Aluminum EPS Explosion Proof Stainless Steel EHA Explosion Proof Aluminum EHI Explosion Proof Iron	FC Factory Configured FW Four Wire RTD LPI Loop Powered Indicator (see page 33 for more details) CC Communications Cable (required to configure PT)	

\* See page 24-25 for more details.

Programmable  
Type LCP



SPECIFICATIONS	Type LCP
Input RTD	RTD 2,3, or 4 Wire Pt100 ( $\alpha=0.00385$ )
Sensor Failure	Upscale
Output	4-20 mA
Operating Temperature	-40°F to +185°F (-40°C to +85°C)
Galvanic Isolation	NO
Power Supply	8.5 to 30 VDC
Intrinsic Safety	FM: Class I, Div. 1, Gr. A-D
Accuracy at 23°C	+/-0.1% of span
Linearization	Temperature Linear Output

LCP – Input and Output Connections		
<p>2 wire RTD PT100</p>	<p>3 wire RTD PT 100</p>	<p>4 wire RTD PT100</p>

Select a designator for each component.  
There is a dash between each designator including options,  
i.e. LPC-0-200°F-3-CA-FC.

TRANSMITTER				
<b>LPC</b>	<b>0-200°F</b>	<b>3 Wire</b>	<b>CA</b>	<b>FC</b>
Model	Range	Sensor Configuration	Head*	Options
	Specify in F or C i.e. 0-200F	2 Wire 3 Wire 4 Wire	CA FTA	Factory Configuration

\* See page 24-25 for more details.



## Loop Powered Indicator Option LPI, LPIX

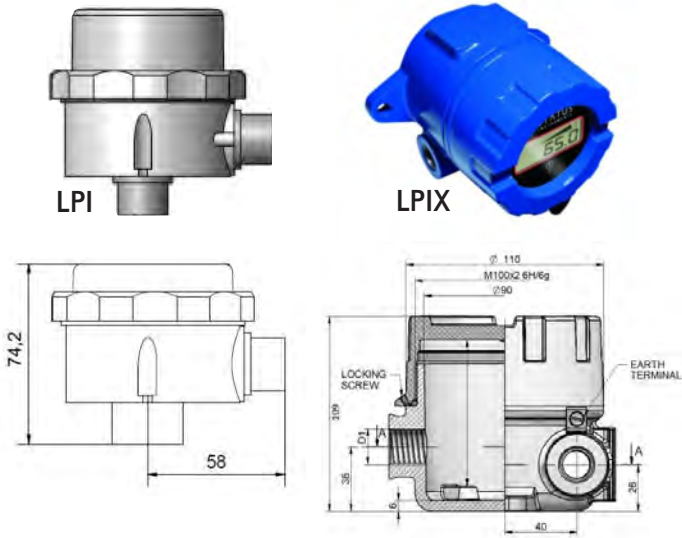

## Battery Powered Indicator Option BPI, BPIX

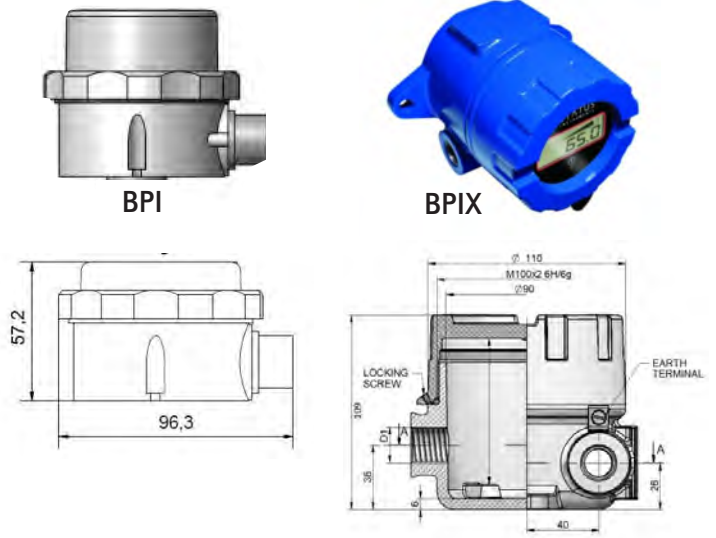

DISPLAY	
Type / options / function	Description
Display height	7.9 mm non-backlit
Display information options some information is displayed scrolling*	6 digits 14 segment input value plus "Warning", "Transmit", "NFC", "USB", "Log", icons, 8 segment log volume/signal indicators. Date and time. Custom messages for visual alarms/information. Relay condition.
Temperature mode	-999999 to 999999 numeric with °C, °F, °R, K
Decimal place	None to 5 places
High intensity LED	Alarm and warning options
*Below -5°C ambient temperatures scrolling messages are not practical due to the update speed of the LCD display. Below this use basic mode only.	
RELAY – Relay 1	
Type / options / function	Description
Type	Single pole change-over (common, N/o, N/c)
Rating	48 VDC maximum @ 1 A (5 mA minimum)
	28 VAC RMS maximum @ 1 A
CERTIFICATIONS	
IP67	Class I Groups A, B, C, D
	Class II Groups E, F, G
	NEMA 4X (Blue Epoxy Coated)

Specifications continued on page 34.

## Loop Powered Indicator

### Option LPI, LPIX

ELECTRICAL INPUT @20°C mA		
Type	Accuracy	Stability
(0 to 20) mA Low signal operating threshold	0.01 % (0.002 mA) 0 mA only with battery fitted*	0.005 %/°C (0.001 mA/ °C)
(4 to 20) mA Low signal operating threshold	0.01 % (0.002 mA) < 1.0 mA *1	0.005 %/°C (0.001 mA/ °C)
Type/ options/ function	Description	Notes
Maximum current	±50 mA	
Loop voltage drop	(2.8 to 3.0) V	
Protection	Resettable fuse 50 mA	Reverse connection

\*Range warning will show below 3.5 mA and above 23 mA

## Battery Powered Indicator

### Option BPI, BPIX

INPUT – RTD (3 Wire) @20°C		
Type	Range	Accuracy / stability
Pt100 (IEC)	(-200 to 850) °C	±0.2°C ±0.05% of reading (plus, sensor error)
Ni120	(-70 to 180) °C	
Thermal drift	0°C at 20°C	Typically, 0.01 Ω/°C Example Pt100 0.03°C/°C

To maintain full accuracy annual calibration is required contact support@status.co.uk for details

INPUT SPECIFICATIONS @20°C Thermocouple		
Type	Range	Accuracy / stability
K	(-150 to 1370) °C	±0.1% of full scale ±0.5°C ± CJ error (plus, sensor error)
J	(-200 to 1200) °C	
N	(-270 to 1300) °C	
E	(-260 to 1000) °C	±0.2% of full scale ±0.5°C ± CJ error (plus, sensor error)
T	(-270 to 400) °C	
R	(0 to 1760) °C	±0.1% of full scale ±0.5°C
S	(0 to 1760) °C	± CJ error (plus, sensor error) over range (800 to 1760) °C S (0 to 1760) °C

CASE SENSOR / COLD JUNCTION (CJ) @20°C		
Type	Range	Accuracy / stability
Thermistor 10K Beta 3380	(-30 to 70) °C	±0.2°C
Thermal drift	0°C at 20°C	±0.05°C/°C

## Loop Powered Direct Mount Indicator

### Option LPCX

SPECIFICATIONS		
Display	5-digit Backlit LCD (4½ neg; 5 pos)	
Power	Loop Powered (18-36 VDC)	
Loop Drop	8.0 V Max	
Input	4-20mA Input	
Input Accuracy	<=0.1% F.S.	
Certification	FM - CSA - ATEX	
	Class I Groups A,B,C,D	Class 1, Zone 1, AEx dIIC
	Class II Groups E,F,G	IEC Ex d II C
	NEMA 4X	IP68

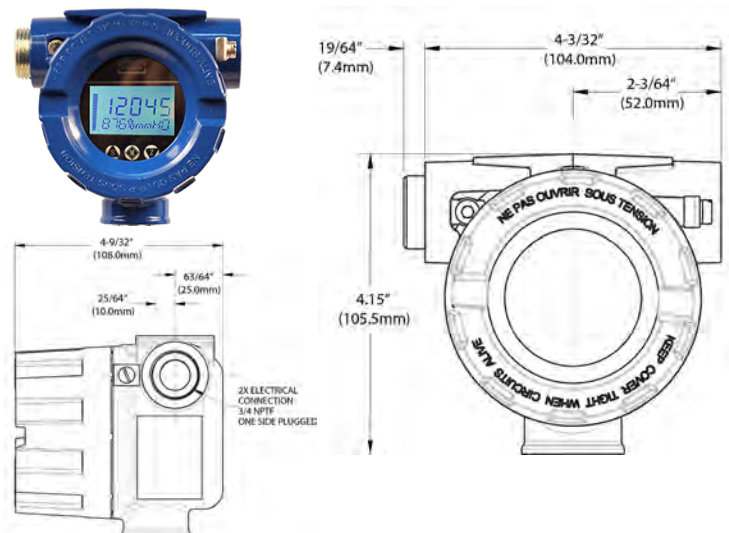

## Adjustable Angle Bimetal Thermometer

The bimetal thermometers are reliable and accurate temperature sensors requiring no electricity or wiring. Adjustable angle thermometers allow for easy temperature monitoring from any position and they are ideal for local indication. They can be recalibrated with a turn of the calibration screw on the back of the dial. A variety of options are available for your specific process needs.



Select a designator for each component. There is a dash between each designator including options, i.e. TI-SSI-A3-2.5-A-F23-PS-S3. If not required leave blank.

THERMOMETER					
TI-SSI	A3	2.5	A	F23	PS-S3

Model	Size	Stem Length	Connection	Range	Options
A3	3" Dial w/ Reset	2.5" (63.5 mm)	A 1/2" NPT	<b>Fahrenheit Ranges</b> F23 -40°F to 160°F	<b>General Options</b> (Choose up to 4) PS = Pointed Stem
A4	4" Dial w/ Reset	4" (101.6 mm)	B 3/4" NPT Adapter	F55 25°F to 125°F*	S3 = 3/8" diameter Stem
A5	5" Dial w/ Reset	6" (152.4 mm)	C 1/2" NPT Adjustable	F43 0°F to 200°F	SF = Silicone Filled
		12" (304.8 mm)	<b>Sanitary</b>	F47 0°F to 250°F	SS = 316 Stainless Stem
		15" (381.0 mm)	D 3/4" Tri-Clamp®	F63 50°F to 300°F	HV = Hi-Vis™ Dial (High Visibility)
		18" (457.2 mm)	E 1.5" Tri-Clamp®	F67 50°F to 500°F	F5 = 5/16" diameter Stem
		24" (609.6 mm)	F 2" Tri-Clamp®	F69 50°F to 550°F	<b>Window Options</b> (Std. is glass)
		30" (762.0 mm)		F81 150°F to 750°F	MM = Min-Max Pointer (Plastic Lens)
		36" (914.4 mm)		F85 200°F to 1000°F	PC = Acrylic Window
		Note: Intermediate stem lengths available up to 80" (203.2 cm).		<b>Celsius Ranges</b>	PY = Polycarbonate Window
				C23 -40°C to 70°C	TG = Tempered Glass Window
				C55 0°C to 50°C*	SG = Laminated Safety Glass
				C43 0°C to 100°C	<b>Calibration Cert. Options</b>
				C47 -20°C to 120°C	C1 = One Point Calibration Cert
				C59 0°C to 150°C	C3 = Three Point Calibration Cert
				C67 0°C to 250°C	CC = Certificate of Conformance
				C69 0°C to 300°C	
				C73 0°C to 400°C	
				C85 100°C to 500°C	

For Thermowells see page 15, 16, 17.

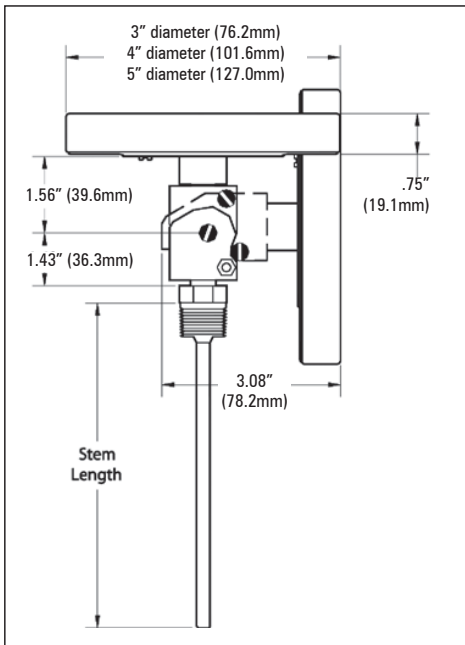

Dual Scale Ranges	
D23	-40°F to 160°F & -40°C to 70°C
D55	25°F to 125°F & -5°C to 50°C*
D43	0°F to 200°F & -10°C to 90°C
D47	0°F to 250°F & -20°C to 120°C
D63	50°F to 300°F & 10°C to 150°C
D67	50°F to 500°F & 10°C to 260°C
D69	50°F to 550°F & 10°C to 290°C
D81	150°F to 750°F & 70°C to 400°C
D85	200°F to 1000°F & 100°C to 500°C

\*Not available in 2.5" stem.

# Temperature Sensors

## Specialty Sensors - Surface Electric Trace Sensor - Model 1500/1500R

### Electric Trace Sensor – Model 1500 and 1500R

**Model 1500** - Used to accurately measure the surface temperature of any pipe or tank greater than 3 inches (7.62 cm) in diameter. The standard X and Y dimensions reduces the heat sink effect and greatly improves the accuracy. The 1500 is widely used for electric heat tracing control for freeze protection and process control, especially where changes in temperature can cause process material to stratify.

**Model 1500R** - This surface temperature design allows easy removal of the sensor. In applications where there is heavy insulation on the pipe the sensor can be removed without disturbing or removing the insulation, reducing replacement downtime and costs.

Select a designator for each component. There is a dash between each designator including options, i.e. CA-1500-J-4-G-3-S.

HEAD		SENSOR				
CA	1500	J	4	G	3	S
Type	Model 1500 or 1500R	Sensor Type	X (see drawings for standard X and Y or indicate desired dimensions in inches)	Junction	Y	Options

#### HEAD TYPE

Model 1500	0	No Head	Model 1500R
	CA	Cast Aluminum	
	CI	Cast Iron	
	CSS	Cast Stainless Steel	
	LCA	Large Cast Aluminum	
	PP	Polypropylene (Black)	
	PPS	Polypropylene Sanitary	
	FTA	Flip Top Aluminum	
	FTP	Flip Top Poly (white)	
	EPA	Explosion Proof Aluminum	
	EPS	Explosion Proof Stainless Steel	
	EHA	Explosion Proof Aluminum	
EHI	Explosion Proof Iron		

#### SENSOR TYPE

Model 1500	J	Iron Constantan®	Model 1500R
	K	Chromel® Alumel®	
	T	Copper Constantan®	
	E	Chromel® Constantan®	
	N	Nicrosil® Nisil®	
	PO	Low Temp RTD to 500°F (260°C)	
	PH	High Temp RTD to 900°F (482°C)	
	PM	Heavy Duty RTD to 900°F (482°C)	

Standard RTD is a three-wire 100 ohm Platinum / .00385 Alpha. For higher temperature ranges - consult factory. For special limits on thermocouples, repeat calibration code, i.e. JJ.

#### SENSOR JUNCTION

Model 1500	G	Grounded	Model 1500R
	U	Ungrounded	
	DG	Dual Grounded	
	DU	Dual Ungrounded	
	S	Single RTD	
	D	Dual RTD	
	FW	Four Wire RTD	

#### OPTIONS

- S 3/4" - 2" (19.1 mm to 50.8 mm) Specify radius
- M Radius for NPT pipe sizes 3" - 6"
- L Radius for NPT pipe sizes 6" and above

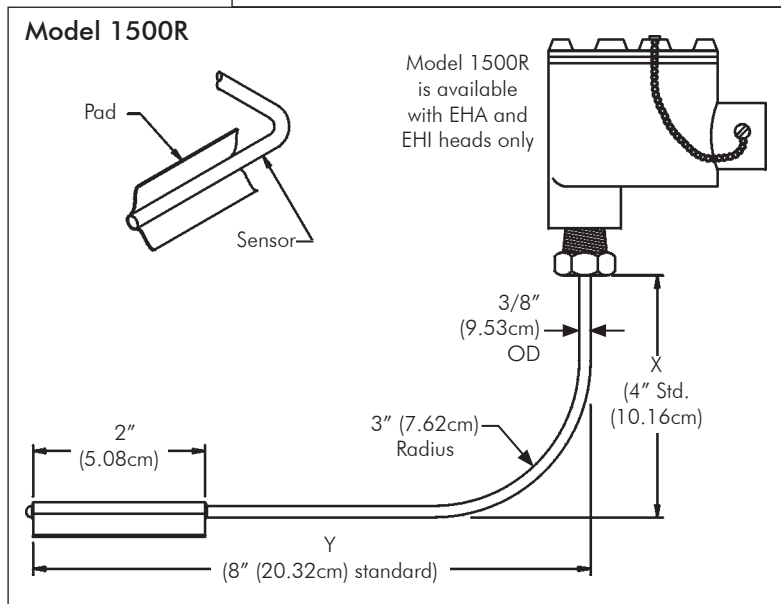
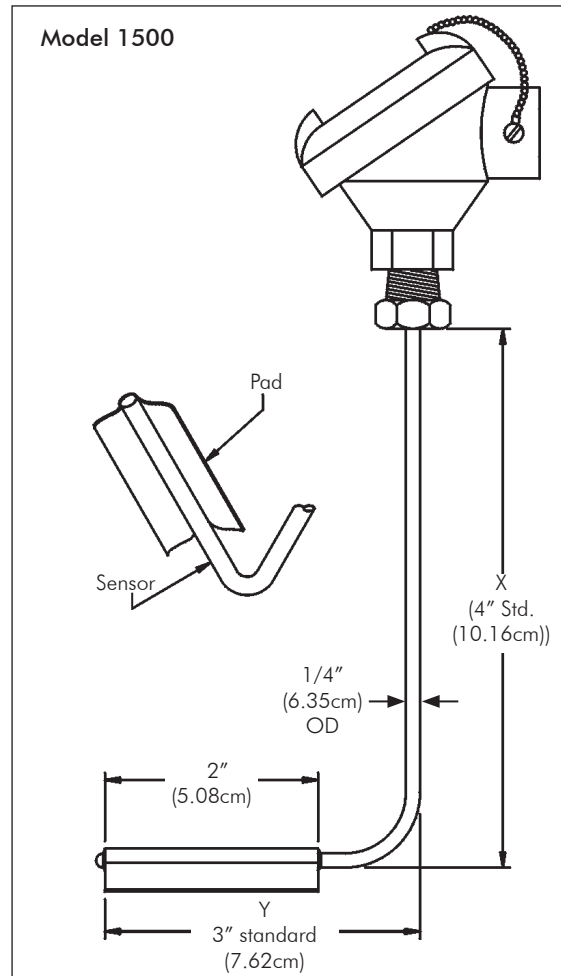

To order replacement sensor for Model 1500R, indicate a designator for each component.

SENSOR REPLACEMENT			
1500RS	PO	11.5	G
Model	Sensor Type	L	Junction

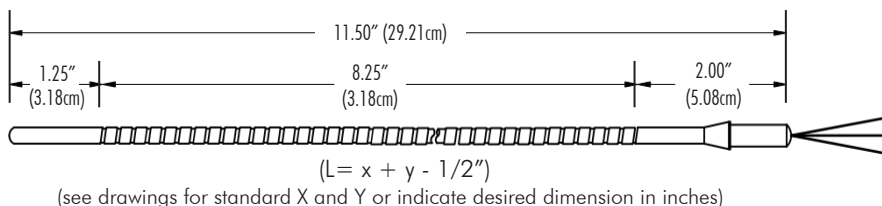

### Pipe Clamp – Model 1550

For heavy duty industrial surface temperatures use Model 1550. The black carbon steel nipple is welded to the black carbon steel pipe clamp adapter and the thermocouple is springloaded and maintains constant contact with the measuring surface. "A" length is normally determined by the insulation thickness surrounding the pipe. Sensor replacement requires no disassembling. For use with pipes 1 to 30 inches in diameter.

Select a designator for each component. There is a dash between each designator, i.e. CA-1550-J-5-G-3.

HEAD		SENSOR			
<b>CA</b>	<b>1550</b>	<b>J</b>	<b>5</b>	<b>G</b>	<b>3</b>
Type	Model	Sensor Type	A Length (inches)	Junction	Pipe Size (inches)

SENSOR	
<b>HEAD TYPE</b>	
0	No Head
CA	Cast Aluminum
CI	Cast Iron
CSS	Cast Stainless Steel
PPS	Polypropylene Sanitary
FTA	Flip Top Aluminum
FTP	Flip Top Poly (white)
EPA	Explosion Proof Aluminum
EPS	Explosion Proof Stainless Steel
EHA	Explosion Proof Aluminum
EHI	Explosion Proof Iron
See page 24-25 for more details.	
<b>SENSOR TYPE</b>	
J	Iron Constantan®
K	Chromel® Alumel®
<b>JUNCTION</b>	
G	Grounded
U	Ungrounded
DG	Dual Grounded
DU	Dual Ungrounded
For special limits on thermocouples, repeat calibration code, i.e. JJ.	

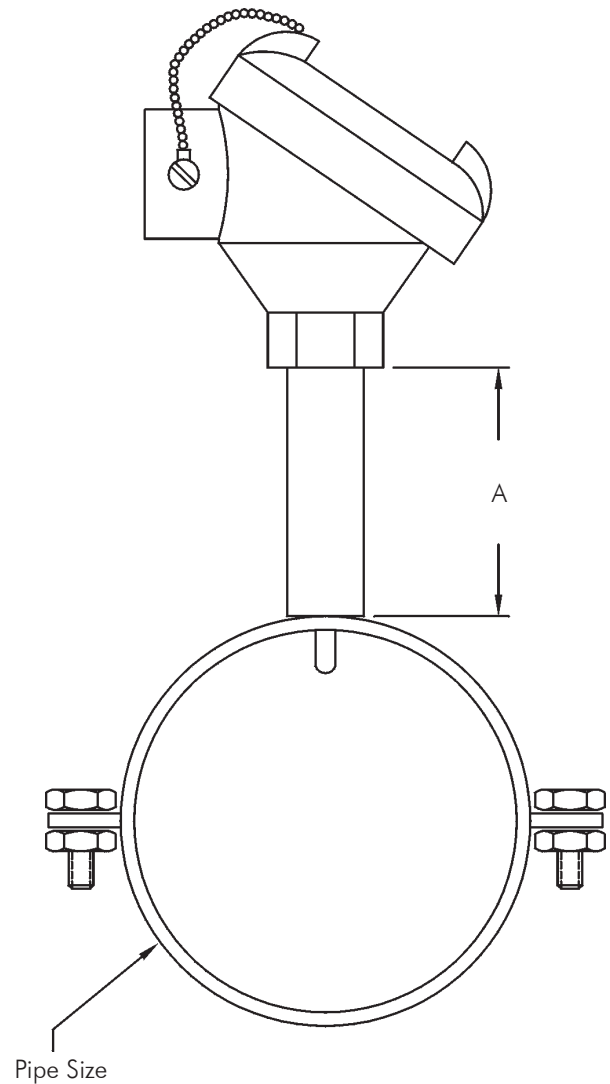

### Washer Thermocouples – Model 1310

Washer thermocouples provide a simple but effective way to measure surface temperature on tanks and other welded metal structures. The thermocouple is imbedded in the washer for quick response and accurate location of the surface temperature.

Wire Gauge: 20 gauge solid (standard)

Select a designator for each component. There is a dash between each designator, i.e. 1310-J-6-F-12-A.

Washer Thermocouple					
<b>1310</b>	<b>J</b>	<b>6</b>	<b>F</b>	<b>12</b>	<b>A</b>
Model	Sensor Type	Washer Size	Leadwire	Lead Wire Length (inches)	Options
	J, K, T, E	6, 8, 10, 12, 0.25" (6.4 mm) 0.375" (9.5 mm) 0.5" (12.7 mm)	F - Fiberglass P - PVC T - Teflon®		A - Armor AP - Armor with PVC Jacket SB - SS Over Braid

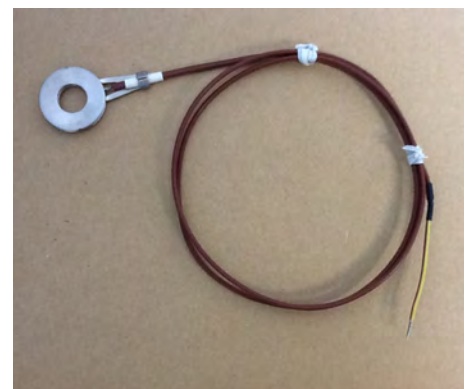

# Temperature Sensors

## Specialty Sensors - Surface Tubeskin Thermocouples - Model 1510/1520

### Tubeskin Thermocouples – Model 1510

Select a designator for each component. There is a dash between each designator including options, i.e. 0-1510-J-18-G-12-P-10-F-2.5-P-A-CT.

HEAD		SENSOR							PIPE/PAD		OPTIONS
0	1510	J	18	G	12	P	10	F	2.5	P	A-CT
Type	Model	Sensor Type	OD	Junction	Sheath Length (inches)	Sheath Material	Lead Length (inches)	Lead Wire	Pipe Size	Pad	
									0.75" to 48"	Mounting	

HEAD TYPE	
0	No Head
CA	Cast Aluminum
CI	Cast Iron
CSS	Cast Stainless Steel
PPS	Polypropylene Sanitary
FTA	Flip Top Aluminum
FTP	Flip Top Poly (white)
EPA	Explosion Proof Aluminum
EPS	Explosion Proof Stainless Steel
EHA	Explosion Proof Aluminum
EHI	Explosion Proof Iron

See page 24-25 for more details.

SENSOR	
SENSOR TYPE	
J	Iron Constantan®
K	Chromel® Alumel®
T	Copper Constantan®
E	Chromel® Constantan®
N	Nicrosil® Nisil®

For special limits on thermocouples, repeat calibration code, i.e. JJ.

OD	
18	1/8" (3.2 mm)
316	3/16" (4.8 mm)
14	1/4" (6.4 mm)
516	5/16" (7.9 mm)
38	3/8" (9.5 mm)

JUNCTION	
G	Grounded
U	Ungrounded
DG	Dual Grounded
DU	Dual Ungrounded

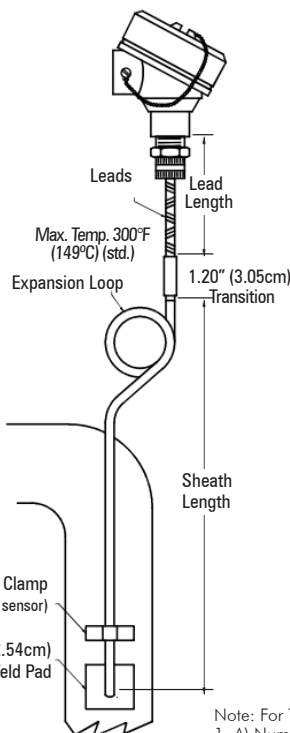
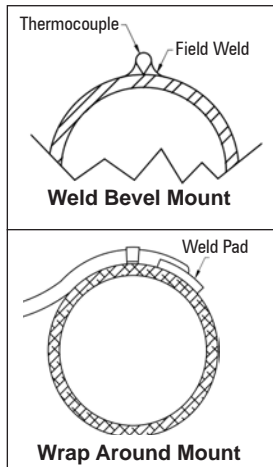

SHEATH MATERIALS	
P	304SS
R	316SS
Q	310SS
A	Alloy 600

Standard sheath material is 316SS.

LEAD WIRE	
F	Fiberglass
T	Teflon®
P	PVC

PIPE MOUNTING	
P	Parallel
W	Wrap Around
BP	Weld Bevel - Parallel
BW	Weld Bevel - Wrap Around
F	Flat

OPTIONS	
A	Armor (Stainless Steel)
AP	Armor with PVC Jacket
BS	Bell Spring Transition Relief
CG12	Weathertight Fitting 1/2" NPT
CT	Compensated Terminals (EHA/EHI heads only)
EL	Expansion Loop
HS	Heat Shield
SB	Stainless Steel Overbraid
SS18	Adj SS Comp Fitting 1/8" NPT*
SS14	Adj SS Comp Fitting 1/4" NPT*
SS12	Adj SS Comp Fitting 1/2" NPT*
ST	Smooth Transition

\*Add T after SS for Teflon® Ferrule  
See page 22-23 for more options.

Note: For Tubeskins with Expansion Loops please provide sketch showing: 1. A) Number of loops, B) Location, C) OD of loops

### Tubeskin Thermocouples – Model 1520

Select a designator for each component. There is a dash between each designator including options, i.e. 0-PNUN-6-1520-N-14-G-36-A-12-W-EL-HS.

HEAD		SENSOR							PIPE/PAD		OPTIONS
0	PNUN	6	1520	N	14	G	36	A	12	W	EL-HS
Type	Extension	A Length (inches)	Model	Sensor Type	OD	Junction	Sheath Length (below bushing-inches)	Sheath Material	Pipe Size	Pad	
									0.75" to 48"	Mounting	

HEAD TYPE	
0	No Head
CA	Cast Aluminum
CI	Cast Iron
CSS	Cast Stainless Steel
PPS	Polypropylene Sanitary
FTA	Flip Top Aluminum
FTP	Flip Top Poly (white)
EPA	Explosion Proof Aluminum
EPS	Explosion Proof Stainless Steel
EHA	Explosion Proof Aluminum
EHI	Explosion Proof Iron

See page 24-25 for more details.

SENSOR	
EXTENSION	
N	Nipple Galvanized
NUN	Nipple/Union/Nipple Galvanized
NS	Nipple Stainless Steel
NUNS	Nipple/Union/Nipple Stainless Steel
PNUN	Pressure Seal in Union Galvanized
PNUNS	Pressure Seal in Union Stainless Steel

See page 26 for more details.

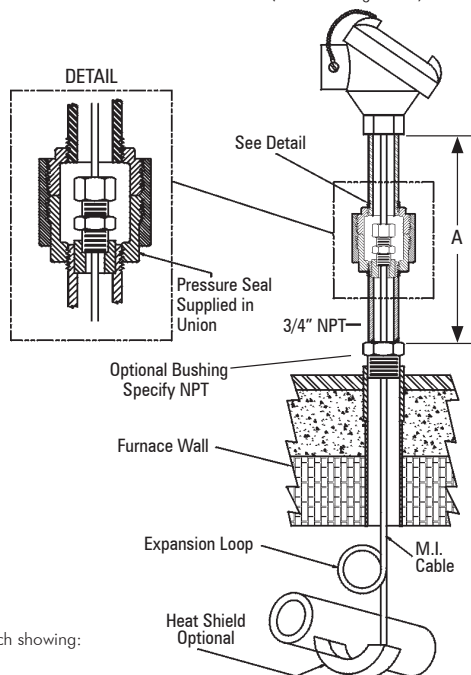

SENSOR TYPE	
J	Iron Constantan®
K	Chromel® Alumel®
T	Copper Constantan®
E	Chromel® Constantan®
N	Nicrosil® Nisil®

For special limits on thermocouples, repeat calibration code, i.e. JJ.

OD	
18	1/8" (3.2 mm)
316	3/16" (4.8 mm)
14	1/4" (6.4 mm)
516	5/16" (7.9 mm)
38	3/8" (9.5 mm)

JUNCTION	
G	Grounded
U	Ungrounded
DG	Dual Grounded
DU	Dual Ungrounded

SHEATH MATERIALS	
P	304SS
R	316SS
Q	310SS
A	Alloy 600

Standard sheath material is 316SS.

PIPE MOUNTING	
P	Parallel
W	Wrap Around
BP	Weld Bevel - Parallel
BW	Weld Bevel - Wrap Around
F	Flat

OPTIONS	
BN	Process Connection NPT (NPT SIZE)
CT	Compensated Terminals (EHA/EHI heads only)
EL	Expansion Loop*
HS	Heat Shield

See page 22-23 for more options.

\*For Tubeskins with Expansion Loops please provide sketch showing: A) Number of loops, B) Location, C) OD of loops

### Oil Seal – Mocal 1312 & 1314

When a bearing is not properly lubricated, premature failure can occur. This failure can prove to be costly. This design has proven successful in measuring various types of bearing temperatures. The sensor provides quick response alerting the operator to an overheated condition. The O-ring prevents lubricants from contaminating components in the head and designed not to swell even when in continuous contact with oils and synthetic lubricants. This feature allows the spring to maintain positive pressure against the bearing housing and assures good temperature readings. This sensor is available with 316SS sheath and 3/16" (4.8 mm) OD. Cast aluminum head is standard. Maximum temperature 400°F (204°C), maximum pressure 50 psi (3.447 bar).

Select a designator for each component. There is a dash between each designator, i.e. 0-1312-PO-316-S-24-FW.

HEAD	SENSOR				OPTIONS	
<b>0</b>	<b>1312</b>	<b>PO</b>	<b>316</b>	<b>S</b>	<b>24</b>	<b>FW</b>
Type	Model	SensorType	OD 316 = 3/16" (4.762 mm)	Junction	Length (inches below fitting)	

HEAD TYPE	
0	No Head
CA	Cast Aluminum
CI	Cast Iron
CSS	Cast Stainless Steel
PPS	Polypropylene Sanitary
FTA	Flip Top Aluminum
FTP	Flip Top Poly (white)
EPA	Explosion Proof Aluminum
EPS	Explosion Proof Stainless Steel
EHA	Explosion Proof Aluminum
EHI	Explosion Proof Iron

See page 24-25 for more details.

SENSOR	
MODEL	
1312	1/2" NPT Process
1314	1/4" NPT Process
SENSOR TYPE	
J	Iron Constantan®
K	Chromel® Alumel®
T	Copper Constantan®
E	Chromel® Constantan®
N	Nicrosil® Nisil®
PO	Low Temp RTD to 500°F (260°C)
PH	High Temp RTD to 900°F (482°C)
PM	Heavy Duty RTD to 900°F (482°C)

Standard RTD is a three-wire 100 ohm Platinum/.00385 Alpha. For higher temperature ranges - consult factory. For special limits on thermocouples, repeat calibration code, i.e. JJ.

JUNCTION	
G	Grounded
U	Ungrounded
DG	Dual Grounded
DU	Dual Ungrounded
S	Single RTD
D	Dual RTD

OPTIONS	
FW	Four Wire
GA	Class A (RTD Only)

See page 22-23 for more options.

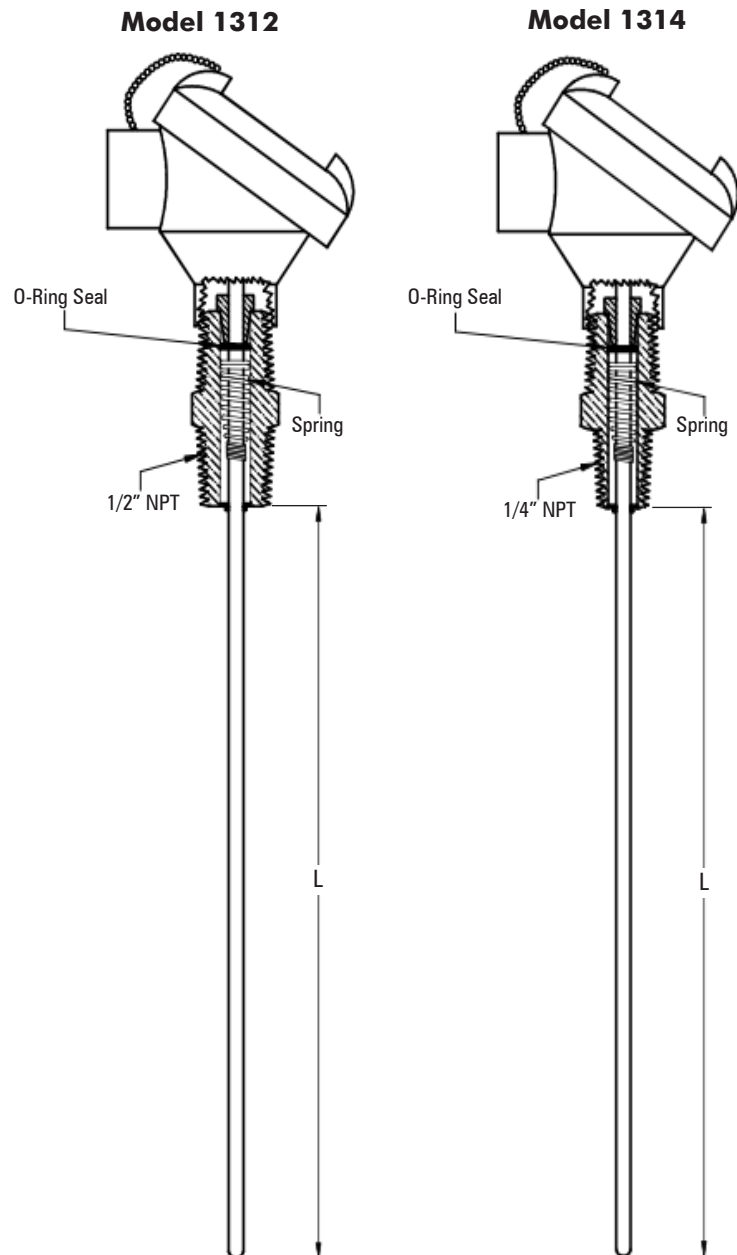

## Model CIP-GP

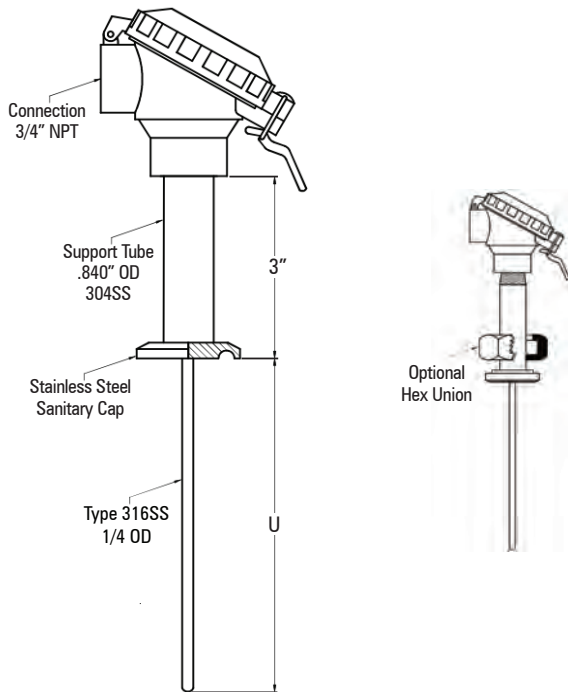

Our SMART CIP-GP (Clean in place) general purpose sanitary RTD offers a standard accuracy that provides uncertainty equal to half that of process accuracies. The high accuracy (HA) option utilizes special manufacturing techniques in delivering the bestknown accuracy in the industry. For improved accuracy specify the Callendar-Van Dusen (CVD) option. This algorithm matches sensor and transmitter uncertainty assuring optimum accuracy. (The CVD option must be used with a transmitter.)

The SMART better than 4 Ra finish resists corrosion and bacteria growth and is designed to meet the requirements of the food, beverage, dairy and pharmaceutical industries.

The SMART sanitary connections come from industry leaders, Ladish, Cherry-Burrell and Alloy and coupled with the standard FDA approved white thermoplastic head allow this design to withstand any washdown process. We recommend our 316 SS head for extremely caustic or high-pressure washdown solutions.

## Model CIP-PRO

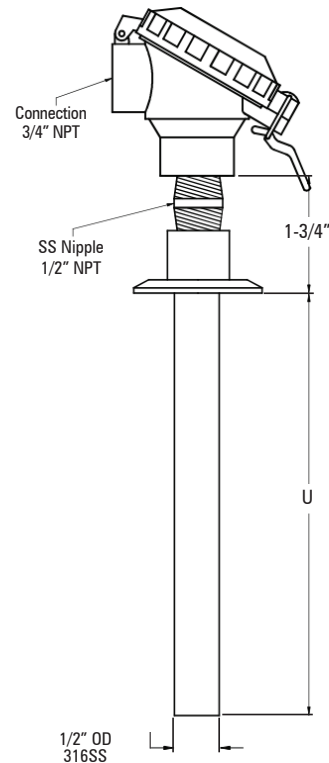

When there is a need to remove the sensor the SMART CIP-PRO protection tube design is the logical choice. The RTD is springloaded to the bottom of the protection tube – this positive metal-to-metal contact improves response time. The RTD is easily removed without disturbing process conditions.

The SMART protection tube is constructed of high quality 316 SS and provides all of the same standard finish characteristics.

Note: Standard surface finish is 4 Ra or better.

Select a designator for each component. There is a dash between each designator including options, i.e. CA-CIP-GP-10-S-1-L16A-HA-FW.

HEAD	SANITARY SENSOR				OPTIONS
CA	CIP-GP	10	S	1	L16A HA-FW
Type	Model	U Length (inches)	Element	Cap Size (inches)	Connection Type

HEAD TYPE	
CA	Cast Aluminum
CSS	Cast Stainless Steel
EPS	Explosion Proof Cast Stainless
FTP	White Flip Top Sanitary
PPS	White Polypropylene Sanitary
See page 24-25 for more details.	
MODEL	
CIP-GP	
CIP-PRO	

U LENGTH	
*Standard Lengths 4", 6", and 9"	
ELEMENT	
S-Single	
CAP SIZE	
1", 1.5", 2", 2.5", 3", 4"	

CONNECTION TYPE	
<b>LADISH TRI CLOVER</b>	
L16A	16 AMP CAP - TRI CLAMP
L16B	16 A CAP BEVEL SEAT
<b>CHERRY BURRELL</b>	
C16A	16 AMP CAP "S" CLAMP
C16B	16 A-14 CAP BEVEL SEAT
<b>ALLOY PRODUCTS</b>	
A16A	16 SOLID END CAP K16A
A16B	16A CAP BEVEL SEAT
<b>HEX UNION NUT OPTION</b>	
HU	USE WITH BEVEL SEAT ONLY

OPTIONS	
HA	High Accuracy
PT	Programmable Transmitter
FW	Four Wire
HC	Hart® Transmitter
CVD	Callendar Van Dusen (Specify transmitter option PT or HC when requesting the CVD curve)
HU	Hex Union Nut
See page 22 for more options.	



## Model CIP-FR

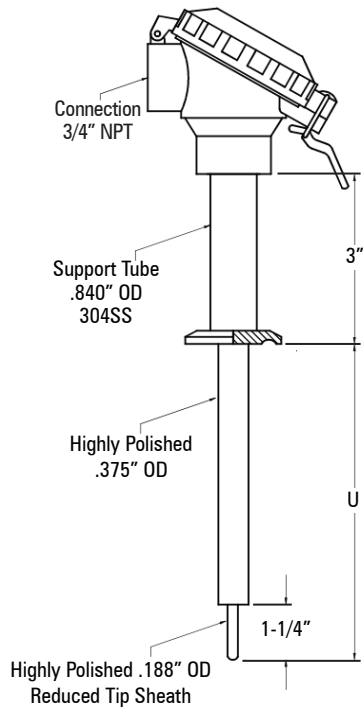

In today's fast reacting process, response time is critical to optimizing product quality and through put. RTD sensors are inherently self-heating and do not possess the fast response time characteristics of other temperature sensors. By carefully selecting materials that are good conductors of heat and through a unique manufacturing technique the SMART CIP-FR typically provides response time of better than four seconds for a 63.2% step change of temperature per ASTM E644.

The SMART CIP-FR has all of the same standard characteristics as the SMART CIP-GP and is an excellent choice for food, beverage, dairy and pharmaceutical applications.

## Model CIP-MINI

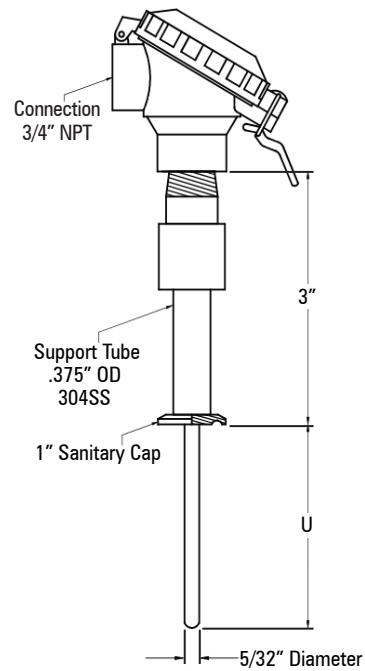

The SMART MINI meets the measurement need for small diameter lines without compromising on washdown bacteria rejection. The caps are welded to the sheath of the RTD and the support tube. All the component parts are 316 stainless steel and process wetted surfaces are free of any pits, crevices, or voids preventing corrosion and bacteria growth. The RTD diameter is 5/32", providing superior response time, without sacrificing reliability. Materials that come in contact with the process meet or exceed the finish requirements of the 3-A Sanitary Council and are designed for direct immersion in sanitary applications.

Note: Standard surface finish is 4 Ra or better.

Select a designator for each component. There is a dash between each designator including options, i.e. CA-CIP-FR-10-S-1-L16A-HA-FW.

HEAD	SANITARY SENSOR					OPTIONS
CA	CIP-FR	10	S	1	L16A	HA-FW
Type	Model	U Length (inches)	Element	Cap Size (inches)	Connection Type	

### HEAD TYPE

CA Cast Aluminum  
 CSS Cast Stainless Steel  
 EPS Explosion Proof Cast Stainless  
 FTP White Flip Top Sanitary  
 PPS White Polypropylene Sanitary  
 See page 24-25 for more details.

### MODEL

CIP-FR  
 CIP-MINI

### U LENGTH

\*Standard Lengths  
 4", 6", and 9"

### ELEMENT

S-Single

### CAP SIZE

0.5" (mini only)  
 0.75" (mini only)  
 1", 1.5", 2", 2.5", 3", 4"

### CONNECTION TYPE

**LADISH TRI CLOVER**  
 L16A 16 AMP CAP - TRI CLAMP  
 L16B 16 A CAP BEVEL SEAT  
**CHERRY BURRELL**  
 C16A 16 AMP CAP "S" CLAMP  
 C16B 16 A-14 CAP BEVEL SEAT  
**ALLOY PRODUCTS**  
 A16A 16 SOLID END CAP K16A  
 A16B 16A CAP BEVEL SEAT

### OPTIONS

HA High Accuracy  
 PT Programmable Transmitter  
 FW Four Wire  
 HC Hart® Transmitter  
 CVD Callendar Van Dusen  
 (Specify transmitter option  
 PT or HC when requesting  
 the CVD curve)  
 HU Hex Union Nut  
 See page 22 for more options.

## Heavy Duty Industrial Magnet Thermocouple – Model 1280

This rugged magnet thermocouple provides hands free surface measurement of tanks, bearing housings, pipes and air ducts. The 25-pound minimum pull magnet allows a strong attachment to rust free and clean surfaces and may be used for temperatures up to 950°F (510°C). A standard bell spring provides stress relief for all lead wire constructions. The optional handle allows proper positioning of the magnet to the measuring surface.

Select a designator for each component. There is a dash between each designator including options, i.e. 1280-J-14-G-12-R-12-T-1-A-HDL.

SENSOR								TERMINATION	OPTIONS
<b>1280</b>	<b>J</b>	<b>14</b>	<b>G</b>	<b>12</b>	<b>R</b>	<b>12</b>	<b>T</b>	<b>1</b>	<b>A-HDL</b>
Model	Sensor Type	OD	Junction	Sheath Length (inches)	Sheath Material	Lead Length (inches)	Lead Insulation		

SENSOR	
<b>SENSOR TYPE</b>	
J	Iron Constantan®
K	Chromel® Alumel®
<b>OD</b>	
18	1/8" (3.2 mm)
316	3/16" (4.8 mm)
14	1/4" (6.4 mm)
<b>JUNCTION</b>	
G	Grounded
U	Ungrounded
DG	Dual Grounded
DU	Dual Ungrounded
<b>SHEATH MATERIAL</b>	
R	316SS
<b>LEAD INSULATION</b>	
T	Teflon® 20 gauge solid
MT	Multi Strand (flexible) Teflon® 20 gauge
<b>TERMINATION</b>	
1	Bare Ends
2	Large Plug
3	Miniature Plug
8	Dual Large Plug
11	Compensated Spade Lugs
<b>OPTIONS</b>	
A	Armor (Stainless Steel)
AP	Armor with PVC Jacket
HDL	Handle
See page 22-23 for more options.	

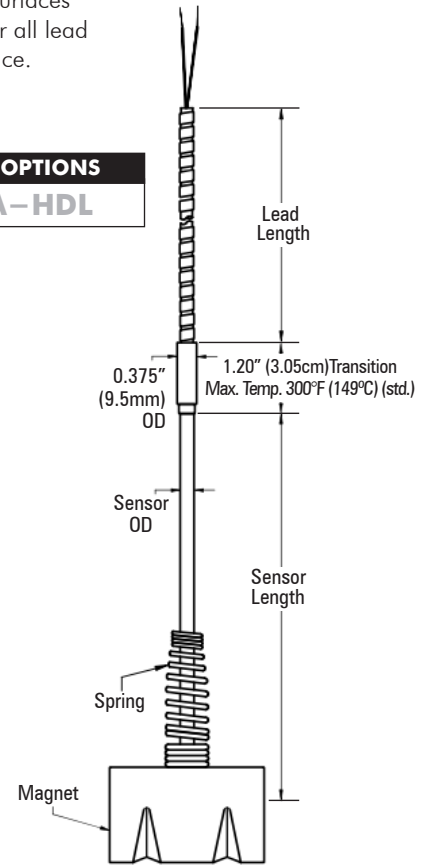

## Heavy Duty Industrial Magnet RTD – Model 1290

When the application requires a temporary RTD surface measurement or has a difficult mounting position - this assembly with a heavy duty magnet could be the solution. Sensor can be easily replaced without removing the magnet or holder and a variety of sensor options are available.

Select a designator for each component. There is a dash between each designator including options, i.e. 1290-PO-14-S-2.25-R-12-MF-1-A.

SENSOR								TERMINATION	OPTIONS
<b>1290</b>	<b>PO</b>	<b>14</b>	<b>S</b>	<b>2.25</b>	<b>R</b>	<b>12</b>	<b>MF</b>	<b>1</b>	<b>A</b>
Model	Sensor Type	OD	Junction	Sheath Length (inches)	Sheath Material	Lead Length (inches)	Lead Insulation		

SENSOR	
<b>RTD Type</b>	
PO	Low Temp RTD to 500°F (260°C)
PH	High Temp RTD to 900°F (482°C)
PM	Heavy Duty RTD to 900°F (482°C)
<b>OD</b>	
14	1/4" (6.4 mm)
<b>Junction</b>	
S	Single RTD
D	Dual RTD
<b>SHEATH MATERIAL</b>	
R	316SS
<b>LEAD INSULATION</b>	
MF	Multi Strand (flexible) Fiberglass 22 gauge.
MT	Multi Strand (flexible) Teflon® 22 gauge.
<b>TERMINATION</b>	
1	Bare Ends
11	Spade Lugs
12	Large Three Pin Plug
14	Mini Three Pin Plug
<b>OPTIONS</b>	
A	Armor (Stainless Steel)
AP	Armor with PVC Jacket
SB	Stainless Steel Overbraided Leads
See page 22-23 for more options.	

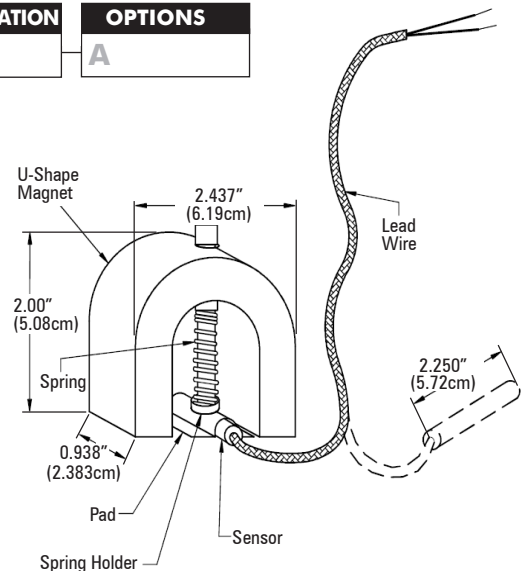

Temperature profiling is important whenever multiple points of measurement are required over a broad measuring range. Multiple Sensor Assemblies or Multipoints as they are commonly referred to can be designed with using either thermocouples or RTDs and in some cases both. As illustrated above, secondary seals can be supplied for even greater safety assurance. These seals prevent process fluids or gasses from escaping in the event of a process upset. In critical applications component testing is recommended. Dye penetrated, X-ray, and hydrostatic testing are standard available tests.

In order to be effective these assemblies must be able to provide temperature point location with a tolerance of plus or minus .25 inches (6.4 mm) and comparable sensor accuracy throughout the entire measuring range. Our calibration method and positive point identification assures like sensor accuracy and accurate and safe performance.

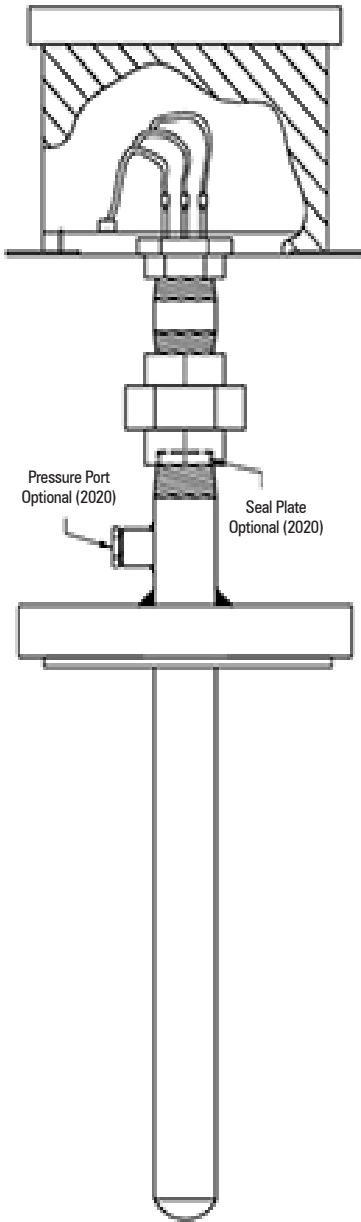

### Guide Tube and Blocks Thermocouple – Model 2020

Sensors are installed into guide tubes which are terminated at the hot end into heat transfer blocks. These blocks are welded into the wall of the protection tube at the required points along the well. This facilitates faster response time, improved accuracy and positive point identification. Individual sensors can be removed while the unit is operating and without disrupting the process. This design lends itself to insertion in a secondary seal construction.

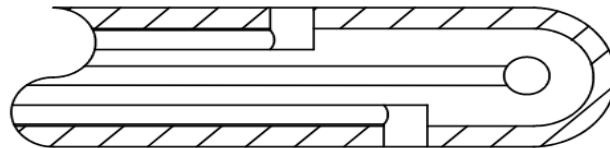

### Positive Contact Thermocouple or RTD – Model 2030

This design maintains positive sensor contact to the inside wall of the protection tube for improved accuracy and response time. The sensors can be installed as a bundle with a support strip or individually. Sensors can be individually replaced.

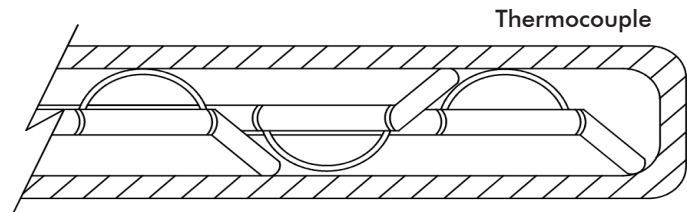
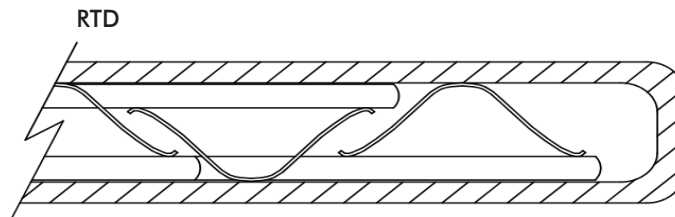

### Miniature Multi Thermocouple or RTD – Model 2040

Several sensors are accurately positioned in a stainless steel tube and each sensor is transitioned to flexible leads. This construction does not require a protection tube.

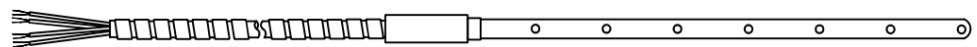

### To Order - provide a sketch with the following information

- Specify Thermocouple Calibration
- Specify Thermocouple Junction-Grounded or Ungrounded
- Specify RTD Type
- Number of Sensors
- Length of each Sensor (measured from the process connection to its measuring point in the pipe well)
- Tube OD
- Tube Material
- Tube Length
- Process Connection
- Lead Length of Sensor
- Lead Insulation
- Lead Termination



TEMPERATURE SENSORS

Smart Sensors | Houston, TX USA | 281-272-5333 | Fax 281-272-5332 | [SmartSensors.com](http://SmartSensors.com)

---

**REGIONAL OFFICES**

**China**

SOR China | Beijing, China | [china@SORInc.com](mailto:china@SORInc.com)  
+86 10 5820 8767 | Fax +86 10 5820 8770

**Middle East**

SOR Measurement & Control Equipment Trading DMCC | Dubai, UAE  
[middleeast@SORInc.com](mailto:middleeast@SORInc.com) | +971 4 278 9632 | Fax +1 913 312 3596