



# 503FR Fixed Range Pressure Transmitter

## General Instructions

The 503FR Fixed Range Pressure Transmitter is a loop powered, solid state instrument designed for accurate and reliable pressure measurement. The transmitter uses a high-performance ceramic sensor and a stainless steel process connection for compatibility with many types of process fluids requiring continuous monitoring.

**NOTE: If you suspect that a product is defective, contact the factory or the SOR® Representative in your area for a return authorization number (RMA). This product should only be installed by trained and competent personnel.**



## Operation

Once the transmitter is installed and wired into a control or display loop, it is ready for use. Before applying power, check that the polarity and excitation voltage are correct.

## Calibration

The transmitter is fixed range and supplied factory calibrated. If it is desired to verify calibration prior to installation, attach the transmitter to a pressure source capable of adjustment throughout a specified range. If outputs are not within limits at factory calibration conditions, 77°F (25°C), the device should be returned to the factory.

*Design and specifications are subject to change without notice.  
For latest revision, go to [www.sorinc.com](http://www.sorinc.com)*

## Installation

Ensure that wiring conforms to all applicable local and national electrical codes and install unit(s) according to relevant national and local safety codes.

Before installing the transmitter, verify that the range stated on the transmitter label is suitable for the pressure to be measured.

The transmitters are designed to be self-supporting in any plane when rigidly mounted by the pressure port (1/4" NPT process connection). Thread the transmitter in place using the wrench flats provided.

Avoid mounting the transmitter near a heat source which is liable to overheat the instrument or cause a temperature gradient across it. If this is unavoidable, introduce a heat shield to deflect radiated heat and thus maintain the transmitter at a uniform temperature within the specified limits.

Although the operating temperature of the transmitter extends to below 32°F, fluids must not be allowed to freeze in the pressure port. Failure will occur due to the expansion of the frozen fluid in the contained volume of the pressure port causing gross over-pressurization. A failure of this nature is not covered by warranty.

## Wiring Details

The 503FR is designed for use in a 2-wire, 4-20 mA system. A system of this type requires that the measuring instrument alter the current consumption of an electric circuit in proportion to pressure changes. The changes in current may be measured using suitable instruments. Due to the design of the transmitter, it is unable to produce currents less than approximately 3.3 mA. Should the transmitter output be "locked" at a figure of this order, it is indicative of a fault and the system should be checked immediately.

Schematic diagrams for incorporation of the transmitter into a control or display loop are shown below. The supply voltage at the transmitter terminals must be between 10 and 32 Vdc on std. units, and between 10 and 28 Vdc on intrinsically safe units. Polarity of the transmitter wiring is essential for proper operation.

## Current Loop

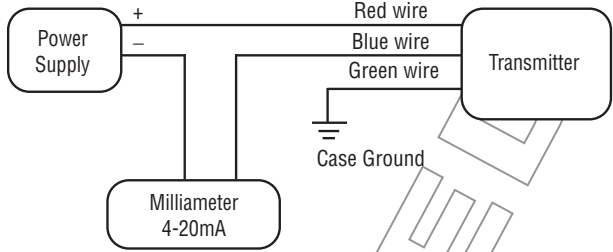

## Voltage Divider

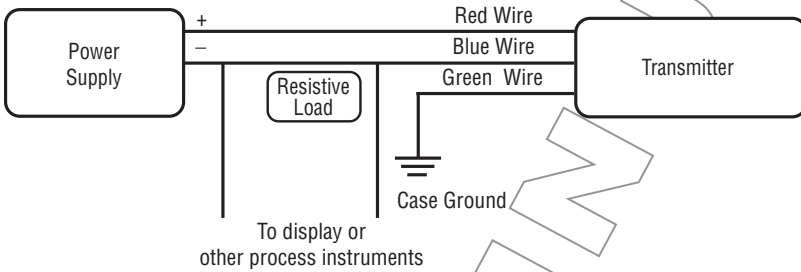

The transmitter will drive into a resistive load, which is a function of the supply voltage. This may be derived from the following formula:

$$R_L (\text{Max}) = \frac{V_{\text{Supply}} - 10V}{I}$$

As noted earlier, the minimum current the transmitter can supply is in the order of 3.3 mA. If a reading of this nature is obtained, it is usually indicative of a fault condition, possibly due to damage to the transmitter caused by over-pressurization or negative pressure being applied to the transmitter.

The red wire is the positive power supply input, the blue wire is the negative power input, and the green is case ground. Reverse connection will prevent the transmitter operating due to its internal reverse polarity protection.

## Servicing

This transmitter contains no user serviceable parts and cannot be repaired on site. It must be returned to the factory. Disassembly of the instrument by unauthorized persons will invalidate the warranty. If there is a risk of debris accumulating in the pressure port, it should be very carefully cleaned.

## Fault Conditions

If a malfunction occurs which is traced to the transmitter, it should be removed for inspection and tested. If the transmitter has been subjected to excess pressure, vibration, shock or extreme supply voltage (as in the case of a lightning strike), damage may be indicated by a constant output, irrespective of the applied pressure. Overpressure may also cause high or unstable readings.

Blocked pressure ports or pipes may cause a similar symptom and should be rectified before carrying out further tests.

The transmitter can withstand pressure of 150% of its rated range without calibration change. Pressures above this may cause irreparable damage. Frequent causes of such overpressures are high transient pressures, which may not be easy to detect during normal operation.

## Dimensions

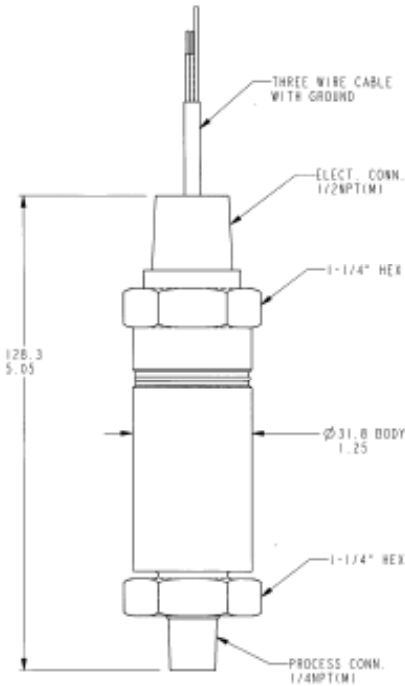

*Dimensions are for reference only.  
Contact the factory for certified drawings for a particular model number.*

Linear = mm/inches

**Drawing 0091140**

Printed in USA



www.sorinc.com

14685 West 105th Street, Lenexa, KS 66215 ■ 913-888-2630 ■ 800-676-6794 USA ■ Fax 913-888-0767