



534HS Mini-Hermet Pressure Transmitter

Form 1176

The 534HS Mini-Hermet pressure transmitter

is a compact loop-powered transmitter. It can be locally ranged in service while maintaining its explosion-proof integrity which differentiates it from non-serviceable instruments. Its performance is comparable to full-size conventional transmitters. The 534HS is suitable for hazardous locations and hostile environments where space is limited. They meet those applications where low-cost, continuous monitoring is preferred.

Features

- Ranges from 5000 to 15000 psig
- 0.25% accuracy
- 4-20 mA, loop powered
- In-service calibration
- EMI/RFI protection
- Intrinsically Safe and explosion proof
- NEMA 4X, IP 66 housing



534HS

Product Specifications

Accuracy (Linearity, Hysteresis and Repeatability)	+0.25% of calibrated span	Output	4 to 20 mA (1-5 VDC optional), loop powered
Turndown 5:1		Loop Resistance	750 ohms @ 24 VDC
Zero Offset	+10% URL	Circuit Protection	Reverse polarity and surge protected
Temperature Range		Construction	316SS housing (CF8M)
Compensated	-20 to 160°F (-29 to 71°C)	Process Connection	1/4" or 1/2" NPT(F)
Ambient	-40 to 185°F (-40 to 85°C)	Electrical Connection	
Process	-40 to 250°F (-40 to 121°C)	Size	1/2" NPT(M)
Storage	-40 to 185°F (-40 to 85°C)	Termination	24 AWG shielded cable, 18-inch length
Temperature Effect	+1% of URL/100°F @ -20 to 160°F	Wetted Materials	316L SST port, ELGILOY diaphragm (standard)
Long-Term Stability	+0.5% URL per year	Weight	1.8 lb. (0.7 kg)
Over-Pressure Protection	1.5X URL for 5K 1.2X URL for 10K, 15K	Warranty	5 years
Response Time	< 25 ms		
Supply Voltage	11-30 VDC		

Design and specifications are subject to change without notice. For latest revision, see sorinc.com.

534HS Mini-Hermet Pressure Transmitter

How to Order

Sample Model Number

534HS - TN 5K - P9 - C 1A - NC

534HS Mini-Hermet pressure transmitter with 4-20mA output, 0-5000 psi, 1/4" NPT and optional NACE certification.

Range	2
0-5000 psi (0-350 bar)	5K
0-10000 psi (0-700 bar)	10K
0-15000 psi (0-1000 bar)	15K

Output	1
4-20 mA	TN
1-5 VDC (required TL accessory)	VN

3	Process Connection Size
1A	1/4" NPT(F)
2A	1/2" NPT(F) (N/A in 10K or 15K Ranges)

4	Accessories
BB	Cleaned for industrial oxygen service
CS	CSA Approved
NC	Compliance to NACE Certification MR0175/ISO 15156
PK	Pipe mounting kit
PP	Fiber tag with customer specified-information
PY	Powder coat epoxy coating. No coating on stainless steel parts or plated screws. (500 hrs - salt spray)
RR	SS tag wired to control with customer-specified information
TL	SS junction box with terminal strip
TT	SS nameplate affixed to housing with customer-specified information
VV	Fungicidal varnish
YY	Epoxy coating. Exterior only. Polyamide epoxy with 316SS pigment. (200 hours - salt spray)
	MAG DRIVER for tamper-proof zero and span adjustments P/N 9003-308

534HS TN 5K P9 C 1A NC ← Model Num-

Agency Approvals

Approved	Safety Method	Approval	Model(s)
CSA	Explosion Proof Intrinsically Safe	Class I, Groups A, B, C & D; Class II, Groups E, F & G; Class III, Divisions 1 & 2	534HS-xxxx-P9-xxx-CS

Test Certificates

534HS	Certificates	C1	C2	C3	C4	C8	B1	B7	A1	A2	A3	A4	A5
	Calibration	◆						◆	◆	◆	◆	◆	◆
Hydrostatic Pressure Test		◆					◆		◆	◆	◆	◆	◆
Inspection Report			◆				◆	◆			◆	◆	
Compliance / Conformance				◆			◆	◆	◆			◆	◆
Typical Material of Wetted Parts						◆	◆	◆	◆	◆	◆	◆	◆

534HS Mini-Hermet Pressure Transmitter

Dimensions

Dimensions shown are for reference only. Contact the factory for certified dimension drawings.
Linear = mm/in.

534HS

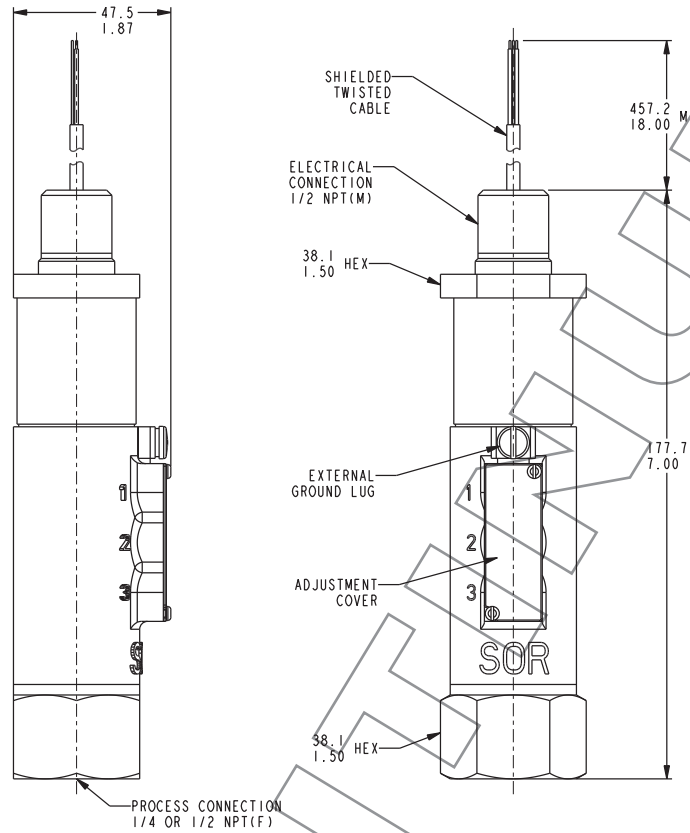

Drawing 0091119

534HS with TL Accessory

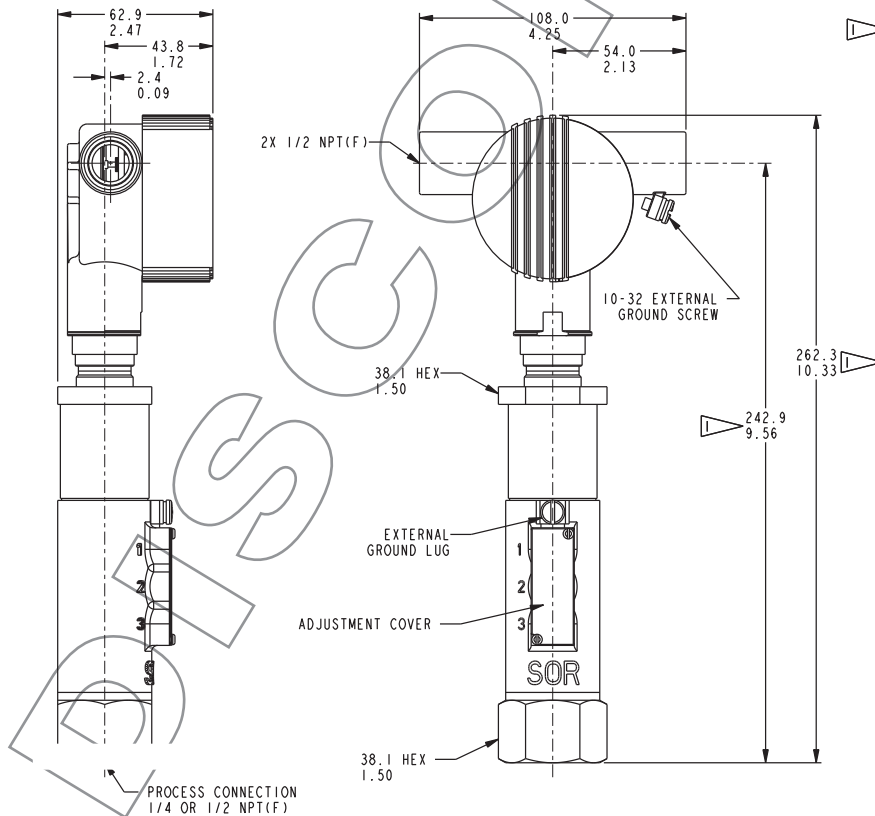

NOTES:

- THIS DIMENSION IS APPROXIMATE AND BASED ON A 5 THREAD ENGAGEMENT.

Drawing 0091124

SOR offers a full line of commercial-grade process instruments.



Engineered to Order with Off-the-Shelf Speed

SOR Inc.

14685 West 105th Street
Lenexa, Kansas 66215

Phone 913-888-2630
Toll Free 800-676-6794
Fax 913-888-0767

sorinc.com

SOR Europe, Ltd.

Farren Court
Cowfold
West Sussex RH13 8BP
United Kingdom

Phone +44 (0) 1403 864000
Fax +44 (0) 1403 864040

SOR - China

Room 903, No. 10 Building
Wan Da Plaza
No. 93 Jian Guo Road
Chao Yang District
Beijing, China 100022

Phone +86 (10) 5820 8767
Fax +86 (10) 58 20 8770

Registered Quality System to ISO 9001

Form 1176 (04.14) ©SOR Inc.