



MEASUREMENT AND CONTROL

Level Detectors

SOR® Mechanical Level Detectors

are rugged, industrial products specifically designed for versatility of application. This catalog contains application and ordering data for float and displacer-operated level detectors. Detectors are available with flanged or sealed chambers or as direct insertion models.

Options available for each type of detector include: detector type and quantity, housing type, chamber material, process connections, accessories, and more. Units may be customized to suit customers' needs.

Inside this catalog you will find solutions to your level sensing puzzles. SOR mechanical level detectors have many configurations available. **If you don't see what you need, we will engineer a custom solution for your application.**



Features and Benefits

- Five-year warranty
- ASME Section IX and AWS qualified welding system
- Designed to ASME B31.1 and B31.3 guidelines
- Hermetically sealed detecting mechanisms available
- Stainless steel detecting mechanisms
- High-temperature capability (up to 1200 °F)
- Wide variety of explosion-proof housings
- Versatile detecting mechanisms which retro-fit into other manufacturers' units
- Worldwide listings and certifications
- Quick worldwide delivery
- ASTM grade materials with certified mill test reports used
- Safety Certified to IEC 61508 (SIL) SOR products are certified to IEC 61508 for non-redundant use in SIL1 and SIL2 Safety Instrumented Systems for most models. For more details or values applicable to a specific product, see the Safety Integrity Level Quick Guide (Form 1528).
- EU Directive 2014/68/EU (PED) available

Standard Chamber Materials

All SOR level detector chambers are constructed using ASTM grade materials with full material certification. Mill Test Reports are kept on file for all raw materials. Copies are available upon request at the time of order placement.

Consult factory for alternative chamber materials.

Carbon Steel Construction	Chamber Center Section A106 Grade B Flanges/Weld Fittings.....A105 Weld Cap A234-WPB Studs/Nuts..... A193-B7/A194-2H
Stainless Steel Construction	Chamber Center SectionA312-TP316/316L Flanges/Weld Fittings A182-316/316L Weld Cap A403-316/316L Studs/Nuts..... A193-B7/A194-2H

Quality Assurance

SOR maintains a high level of quality throughout our corporation. Many quality assurance features are built into our products.

- ISO 9001 certified engineering design and production system (certified since 1993).
- Level-welded chambers designed to the guidelines of ASME B31.1 and B31.3 (inspection certificate available – see page 29).
- All welders and weld procedures are qualified and maintained to ASME Section IX.
- All ASTM grade materials used - Certified Mill Test Reports required on all raw materials.

Detecting Mechanisms

SOR detecting mechanisms are designed for use in punishing industrial conditions.

- All stainless steel construction - no aluminum or brass.
- Temperature ratings available from -65°F (-54°C) to 1000°F (538°C) on dry, non-condensing services.
- Condensing service (steam) temperature ratings available up to 800°F (427°C), and up to 1200°F (649°C) with protection (see page 26).
- Available detecting mechanisms include hermetically sealed, standard open contacts, or pneumatic contacts.
- Agency listings are available on most detector mechanisms: UL, CSA, ATEX or IECEx.

Gaskets

- All standard models are provided with a Nitrile binder composite gasket that is selected for its resistance to hydrocarbons and steam.
- For high-temperature, high-pressure or NACE-constructed units, a spiral-wound gasket is used with 316SS wound-around Grafoil.
- Extreme high-pressure model 802 uses a soft-iron, ring-joint gasket on the chamber head flange.

Internal Trim

- All sensing elements (floats and displacers) are constructed of either 316/316LSS or porcelain as a minimum.
- Attraction sleeves are available in 400SS as a standard, with 316/316LSS or other exotic metals as an option.
- All other wetted internal parts are 316SS or better. Displacer springs are made of Inconel 600.

Product Support

SOR has a full-time engineering staff dedicated to solving your mechanical level detector problems. Engineers and technicians are knowledgeable about sales and production techniques, and are dedicated to providing the best solution to our customers at the best price.

Section	Page
Principles of Operation	4
Model Tree	6
Step 1a: Float or Displacer & Model Series	7
Step 1b: Pressure Rating and Specific Gravity	8
Step 2: Chamber/Process Connection Material.....	14
Step 3: Process Connection.....	15
Step 4: Trim Material	18
Step 5: Detecting Mechanism	19
Step 6: Housing	22
Step 7: Accessories/Certificates	23
High Temperature Selection	25
Manual Check (MC) & True Check (TC) Options	28
Examination and Testing Requirements	29
SOR Standard Inspection & Testing Certifications	30
ASTM Material Designations	31
Weights	32
Specific Gravity of Water	33
Dimensions	
100 Series	34
200 Series.....	35
108/208 Models	38
300 Series.....	39
400 Series.....	40
741-743, 802 Models	41
740, 804 Models	43
700 Series	45
730 Series	46
750 Series.....	47

Level Detectors

Principles of Operation

Float-Operated Level Detectors - Vertical

Model Series 100, 200 and 300

The float rides on the process liquid surface, precisely tracking liquid surface motion.

Rising liquid level lifts the float, sliding the attraction sleeve up inside the enclosing tube and into the magnetic field to actuate the electrical or pneumatic detector (signaling liquid presence).

Subsequently, falling liquid level lowers the float, drawing the attraction sleeve out of the magnetic field to deactivate the electrical or pneumatic detector (signaling liquid absence). Float-type level detectors are generally able to handle high-temperature applications, and sometimes prove useful for close interface detection.

Floats can operate up to two detecting elements. Independent detecting levels may be obtained with tandem floats. **Consult the factory for special float-detecting arrangements.**

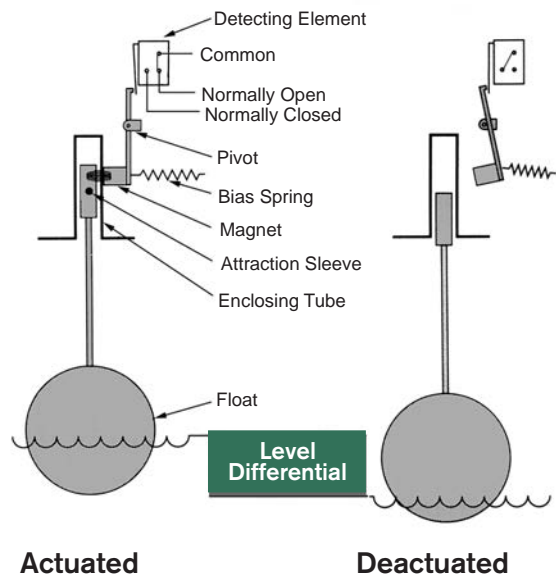

Float-Operated Level Detectors - Horizontal

Model Series 108/208 and 400

The float rides on the process liquid surface, precisely tracking liquid surface motion.

Rising liquid level lifts the float via a pivot mechanism, sliding the attraction sleeve down inside the enclosing tube and out of the magnetic field to deactivate the electrical or pneumatic detector (signaling liquid presence).

Subsequently, falling liquid level lowers the float, drawing the attraction sleeve into the magnetic field to actuate the electrical or pneumatic detector (signaling liquid absence). Float-type level detectors are generally able to handle high-temperature applications.

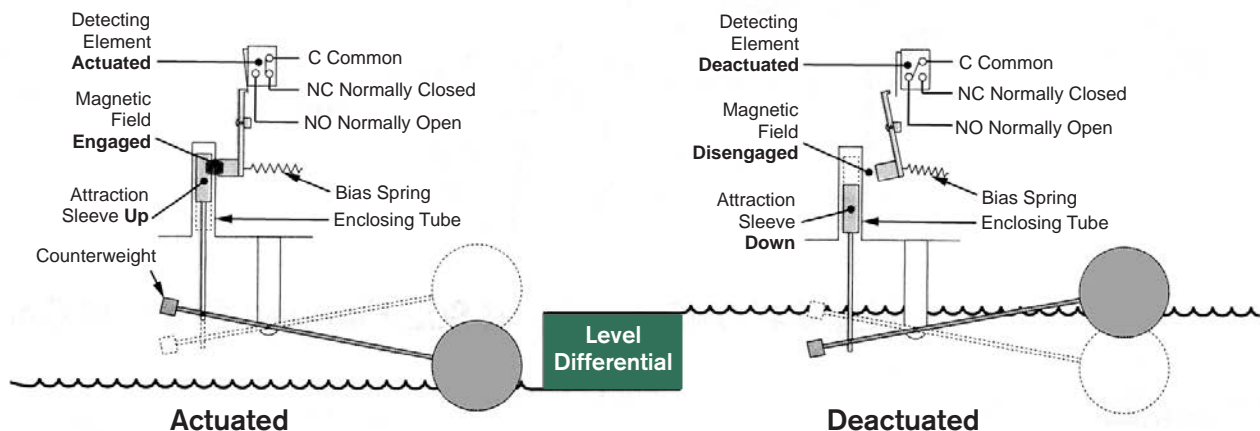

Displacer-Operated Level Detectors

Model Series 700, 730, 740, 750 and 800

Displacer controls offer alternative features to the float-operated control. The sensor is a weight (displacer), heavier than the liquid, that is suspended by a spring. When liquid contacts the displacer, a buoyancy force is produced, which causes the effective weight of the displacer to change. This causes the spring to retract slightly to a new equilibrium position. When the spring retracts, the attraction sleeve also moves upward into the field of the external magnet, thus overcoming the force of the bias spring and actuating the detecting element.

This principle provides for narrow or wide detecting differential, and allows detecting point alteration by moving the displacer(s) up or down the suspension cables.

Displacers may be arranged in combinations of narrow and wide differential to operate up to three detecting stages. Displacer controls operate under higher pressure conditions than float-operated detectors.

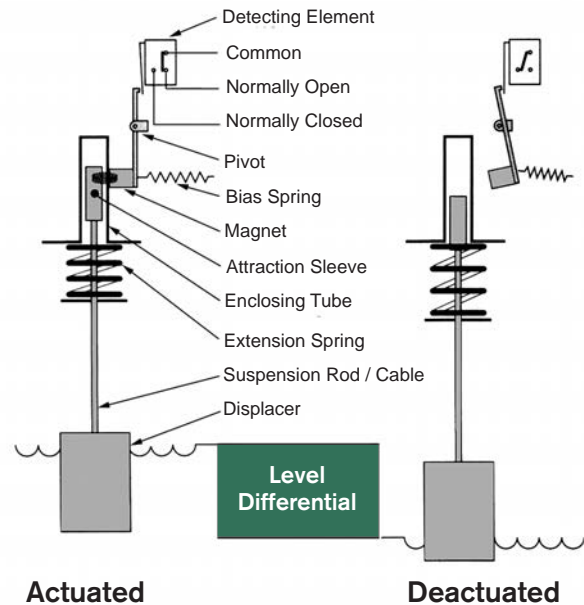

How to Order

Below is the SOR quick select model number tree that provides you with options to configure and order a product for your application.

- You must select a **designator** for each component (see corresponding pages)
- Reference tables, charts and additional information are provided throughout the catalog to help you make your selections.

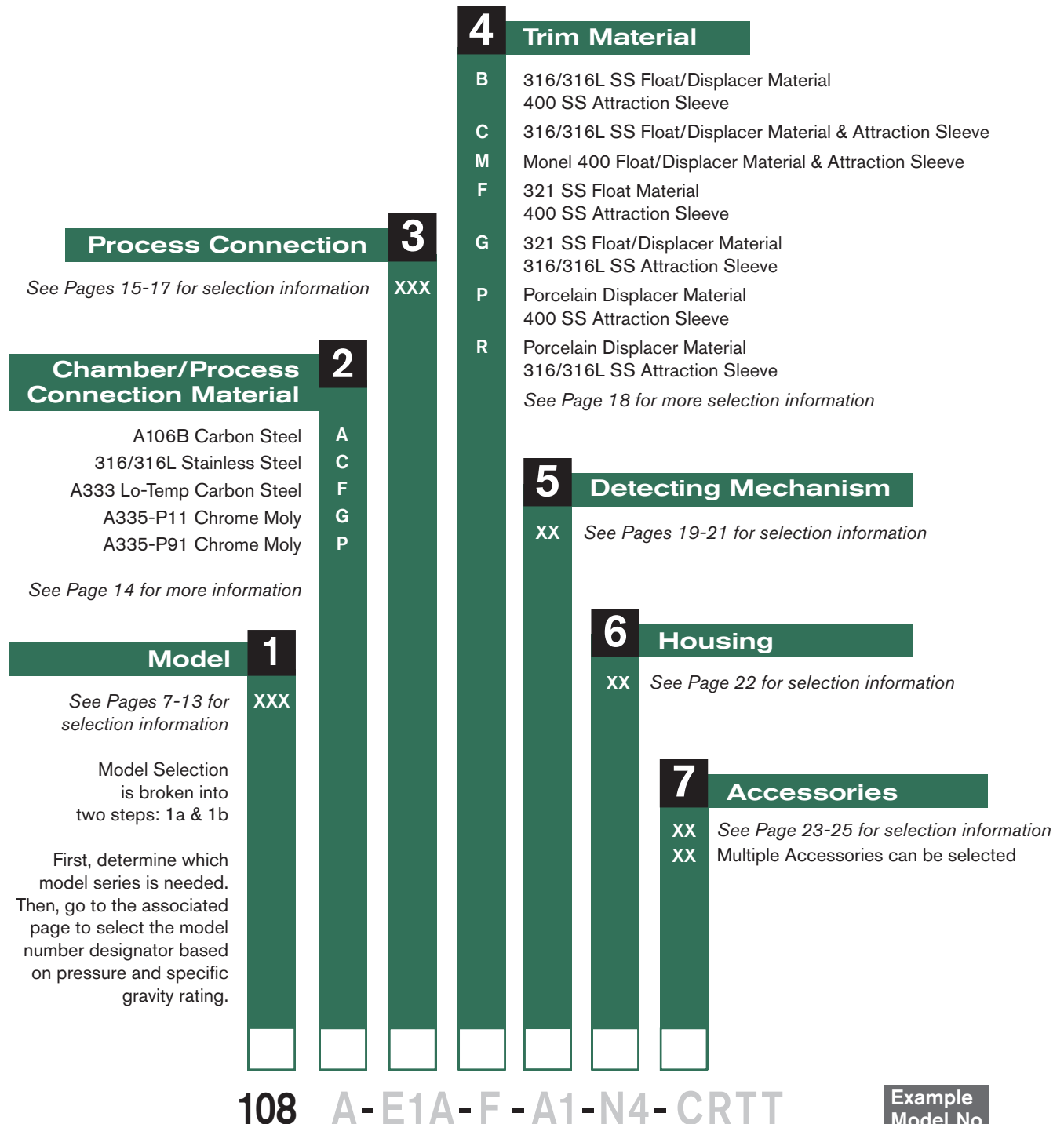

Level Detectors

Step 1a: Model Selection FLOAT or DISPLACER

The first step to creating your model number is to determine whether a float or a displacer-based level detector is needed. See below for the different options for selecting the right technology for a specific application.





Float Selection

Float detectors are inherently less expensive as they have a very simple operating mechanism compared to displacer technology. Because of this, they can operate extremely well in high temperature applications. The performance and functionality of a float detector are unaffected by changes in process conditions such as temperature, pressure, and dielectric properties. Floats however have limited pressure and SG capabilities compared to displacer technologies.

Displacer Selection

Displacer based type level detectors have high pressure capabilities and can be used for level control and interface detection. Because it operates as a force balance, displacers can achieve lower SG capabilities than float based technologies. Displacer technologies are limited by temperature as the higher temperatures change the properties of the spring used as a counterforce of the displacer.

Model Series	Application
 <p>100 Series Flanged Serviceable External Chamber Float Detector (p. 8)</p>	<ul style="list-style-type: none"> Indirect mount is required because tank cannot be easily shutdown for service When turbulence is high enough to cause false readings/damage to the float Flanged service connection for maintenance, cleaning, or troubleshooting
 <p>200 Series Sealed Non-Serviceable External Chamber Float Detector (p. 9)</p>	<ul style="list-style-type: none"> Indirect mount is required because tank cannot be easily shutdown for service When turbulence is high enough to cause false readings/damage to the float The chamber is welded to prevent tampering and is lower cost
 <p>108, 208 Steam Condensate External Chamber Float Detector (p. 9)</p>	<ul style="list-style-type: none"> Horizontal float detector designed specifically to handle high temperature/pressure Low SG capabilities Steam applications Serviceable/Non-serviceable options
 <p>300 Series Top Insertion Mount Float Detector (p. 10)</p>	<ul style="list-style-type: none"> Quick and easy installation; direct mount Low Cost Solution Used for high level alarm/overflow protection
 <p>400 Series Side Insertion Mount Float Detector (p. 10)</p>	<ul style="list-style-type: none"> Quick and easy installation; direct mount Used for specific point level indication Can be installed at any height of the tank

Model Series	Application
 <p>741-743, 802 Flanged Serviceable External Chamber Displacer Detector (p. 11)</p>	<ul style="list-style-type: none"> Indirect mount is required because tank cannot be easily shutdown for service When turbulence is high enough to cause false readings/damage to the displacer Flanged service connection for maintenance, cleaning, or troubleshooting
 <p>740, 804 Sealed Non-Serviceable External Chamber Displacer Detector (p. 11)</p>	<ul style="list-style-type: none"> Indirect mount is required because tank cannot be easily shutdown for service When turbulence is high enough to cause false readings/damage to the displacer The chamber is welded to prevent tampering and is lower cost
 <p>700 Series Single-Stage Top Insertion Mount Displacer Detector (p. 12)</p>	<ul style="list-style-type: none"> Used for high alarm or level control through adjustable wide differential option Direct tank mount
 <p>730 Dual-Stage Top Insertion Mount Displacer Detector (p. 12)</p>	<ul style="list-style-type: none"> Used for high-high, high-low, and low-low level alarms Direct tank mount
 <p>750 Triple-Stage Top Insertion Mount Displacer Detector (p. 13)</p>	<ul style="list-style-type: none"> Three detecting points to provide numerous combinations of ways to configure the point level detector outputs Direct tank mount

Level Detectors

Step 1b: Model Selection Pressure Rating & Specific Gravity

STEP
1b

108 A-E1A-F-A1-N4-CRTT

Using selected Model, refer to the charts on pages 8-13 to match required pressure rating and specific gravity, based on design temperature. Once model number has been selected, go to page 14 for Step 2. **Consult factory for ratings of alternative chamber materials.**



100 Series Float operated with a flanged, serviceable external chamber.

Maximum Working Pressure See page 27 for higher temperatures.

Model	Chamber Material	Pressure at Listed Temperature in psi (bar)*					
		100°F (38°C)	200°F (93°C)	300°F (149°C)	350°F (177°C)	400°F (204°C)	450°F (232°C)
101	A106B	285 (19.7)	260 (17.9)	230 (15.9)	215 (14.8)	200 (13.8)	185 (12.8)
	316SS	275 (18.9)	235 (16.2)	215 (14.8)	205 (14.1)	195 (13.4)	182 (12.6)
102	A106B	500 (34.5)	500 (34.5)	500 (34.5)	486 (33.5)	473 (32.6)	460 (31.7)
	316SS	500 (34.5)	500 (34.5)	500 (34.5)	486 (33.5)	473 (32.6)	460 (31.7)
103	A106B	740 (51.0)	675 (46.6)	655 (45.2)	645 (44.5)	635 (43.8)	622 (42.9)
	316SS	720 (49.7)	620 (42.8)	560 (38.6)	537 (37.0)	515 (35.5)	497 (34.3)
104	A106B	990 (68.2)	900 (62.0)	875 (60.3)	860 (59.2)	845 (58.2)	822 (56.6)
	316SS	1000 (69.0)	1000 (69.0)	1000 (69.0)	973 (67.1)	946 (65.2)	920 (63.4)
109	A106B	285 (19.7)	260 (17.9)	230 (15.9)	215 (14.8)	200 (13.8)	185 (12.8)
	316SS	275 (18.9)	235 (16.2)	215 (14.8)	205 (14.1)	195 (13.4)	182 (12.6)
121	A106B	285 (19.7)	260 (17.9)	230 (15.9)	215 (14.8)	200 (13.8)	185 (12.8)
	316SS	275 (18.9)	235 (16.2)	215 (14.8)	205 (14.1)	195 (13.4)	182 (12.6)
122	A106B	350 (24.1)	350 (24.1)	350 (24.1)	340 (23.4)	331 (22.8)	322 (22.2)
	316SS	350 (24.1)	350 (24.1)	350 (24.1)	340 (23.4)	331 (22.8)	322 (22.2)
123	A106B	740 (51.0)	675 (46.6)	655 (45.2)	645 (44.5)	635 (43.8)	622 (42.9)
	316SS	720 (49.7)	620 (42.8)	560 (38.6)	537 (37.0)	515 (35.5)	497 (34.3)
124	A106B	1250 (86.2)	1250 (86.2)	1250 (86.2)	1216 (83.9)	1182 (81.5)	1150 (79.3)
	316SS	1250 (86.2)	1250 (86.2)	1120 (77.2)	1075 (74.1)	1030 (71.0)	992 (68.2)

Minimum Specific Gravity

Model	Single Detector			
	Note: Dual Detector, anti-vibration, pneumatic or extra-high temperature in ()			
	Standard		w/ ET or FE Option	
	316SS / 400SS "B" Trim	All 316SS "C" Trim	316SS / 400SS "B" Trim	All 316SS "C" Trim
101	0.52 (0.64)	0.56 (0.67)	0.56 (0.67)	0.60 (0.71)
102	0.62 (0.73)	0.66 (0.77)	0.65 (0.76)	0.69 (0.80)
103	0.51 (0.57)	0.53 (0.59)	0.53 (0.59)	0.55 (0.61)
104	0.62 (0.68)	0.64 (0.70)	0.64 (0.70)	0.66 (0.72)
109	0.38 (0.41)	0.39 (0.42)	0.39 (0.42)	0.40 (0.43)
121	0.66 (0.87)	0.73 (0.94)	0.72 (0.93)	0.79 (1.01)
122	0.66 (0.87)	0.73 (0.94)	0.72 (0.94)	0.79 (1.01)
123	0.93	0.98	0.99	1.04
124	0.94	0.99	1.00	1.05

*Consult the factory for pressure ratings and minimum SG of units with Monel trim.

Level Detectors

Step 1b: Model Selection Pressure Rating & Specific Gravity

STEP
1b

108 A-E1A-F-A1-N4-CRTT

200 Series Float-operated with sealed, tamper-proof external chamber.

Maximum Working Pressure See page 27 for higher temperatures.

Model	Chamber Material	Pressure at Listed Temperature in psi (bar)*					
		100°F (38°C)	200°F (93°C)	300°F (149°C)	350°F (177°C)	400°F (204°C)	450°F (232°C)
201	A106B 316SS	225 (15.5)	225 (15.5)	225 (15.5)	219 (15.1)	213 (14.7)	207 (14.3)
202	A106B 316SS	300 (20.7)	300 (20.7)	300 (20.7)	292 (20.1)	284 (19.5)	276 (19.0)
203	A106B 316SS	500 (34.5)	500 (34.5)	500 (34.5)	486 (33.5)	473 (32.6)	460 (31.7)
204	A106B 316SS	1250 (86.2)	1250 (86.2)	1250 (86.2) 1187 (81.9)	1216 (83.9) 1139 (78.6)	1182 (81.5) 1091 (75.2)	1150 (79.3) 1052 (72.6)
205	A106B 316SS	750 (51.7)	750 (51.7)	750 (51.7)	729 (50.3)	709 (48.9)	690 (47.6)
206	A106B 316SS	1000 (68.9)	1000 (68.9)	1000 (68.9) 945 (65.2)	973 (67.1) 907 (62.6)	946 (65.2) 869 (59.9)	920 (63.4) 838 (57.8)
207	A106B 316SS	1000 (68.9)	1000 (68.9)	1000 (68.9) 945 (65.2)	973 (67.1) 907 (62.6)	946 (65.2) 869 (59.9)	920 (63.4) 838 (57.8)
209	A106B 316SS	450 (31.0)	450 (31.0)	450 (31.0)	438 (30.2)	426 (29.4)	414 (28.6)
221	A106B 316SS	350 (24.1)	350 (24.1)	350 (24.1)	340 (23.4)	331 (22.8)	322 (22.2)



Minimum Specific Gravity

Model	Single Detector			
	Note: Dual Detector, anti-vibration, pneumatic or extra-high temperature in ()			
	Standard		w/ ET or FE Option	
	316SS / 400SS "B" Trim	All 316SS "C" Trim	316SS / 400SS "B" Trim	All 316SS "C" Trim
201	0.38 (0.44)	0.40 (0.46)	0.40 (0.44)	0.42 (0.48)
202	0.52 (0.63)	0.55 (0.67)	0.55 (0.66)	0.59 (0.70)
203	0.61 (0.72)	0.65 (0.76)	0.64 (0.75)	0.68 (0.79)
204	0.91	0.96	0.98	1.03
205	0.50 (0.56)	0.52 (0.58)	0.52 (0.58)	0.54 (0.60)
206	0.65 (0.75)	0.68 (0.79)	0.68 (0.79)	0.71 (0.82)
207	0.61 (0.67)	0.63 (0.69)	0.63 (0.69)	0.65 (0.71)
209	0.38 (0.41)	0.39 (0.42)	0.39 (0.42)	0.40 (0.43)
221	0.64 (0.86)	0.72 (0.93)	0.71 (0.92)	0.78 (0.99)

*Consult the factory for pressure ratings and minimum SG of units with Monel trim.

108/208 Float operated, horizontal mounted detectors with sealed, tamper-proof or fanged, serviceable chambers. See page 27 for pressure ratings at higher temperatures.

Maximum Working Pressure

Model	Chamber Material	Pressure at Listed Temperature in psi (bar)					
		100°F (38°C)	200°F (93°C)	300°F (149°C)	350°F (177°C)	400°F (204°C)	450°F (232°C)
108	A106B 316SS	740 (51.0)	675 (46.5)	655 (45.1)	645 (44.4)	635 (43.7)	622 (42.8)
		720 (49.6)	620 (42.7)	560 (38.6)	537 (37.0)	515 (35.5)	497 (34.2)
208	A106B 316SS	1794 (123.6)	1794 (123.6)	1794 (123.6)	1794 (123.6)	1794 (128.0)	1794 (128.0)
		2248 (155.0)	1937 (133.5)	1746 (120.3)	1644 (133.4)	1602 (110.4)	1548 (106.7)

Minimum Specific Gravity For all model series 108/208, single detector only is equal to .65

Consult the factory for units used with specific gravity lower than .65.

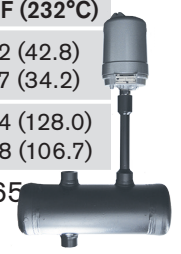

300 Series Float-operated and suitable for top-insertion mounting.

Maximum Working Pressure

Model	Pressure at Listed Temperature in psi (bar)*					
	100°F (38°C)	200°F (93°C)	300°F (149°C)	350°F (177°C)	400°F (204°C)	450°F (232°C)
301	225 (15.5)	225 (15.5)	225 (15.5)	219 (15.1)	213 (14.6)	207 (14.2)
303	500 (34.4)	500 (34.4)	500 (34.4)	486 (33.5)	473 (32.6)	460 (31.7)
304	750 (51.7)	750 (51.7)	750 (51.7)	729 (50.2)	709 (48.8)	690 (47.5)

Minimum Specific Gravity

Model	Insertion Depth** (inches)	Single Detector		
		Note: Dual Detector, anti-vibration, pneumatic or extra-high temperature in ()		
		316SS/400SS Trim (B)	All 316SS Trim (C)	All Monel Trim (M)
301	24	.40 (.45)	.42 (.48)	.48 (.54)
	48	.44 (.49)	.46 (.52)	.53 (.59)
303	24	.68 (.79)	.72 (.84)	.82 (.93)
	48	.75 (.87)	.80 (.91)	.91 (1.02)
304	24	.52 (.58)	.55 (.61)	.62 (.68)
	48	.56 (.62)	.59 (.65)	.67 (.73)



* Consult the factory for pressure ratings and minimum SG of units with Monel trim.

** Insertion depth is defined as the approximate value of a rising level setpoint at a Specific Gravity of 1.0.

If more precise setpoint action is required, please select the SC option from the accessories section of the catalog.

Note: An insertion depth or SC information must be supplied at the time of order on all 300 series detectors.

400 Series Float-operated and suitable for horizontal-insertion mounting.

Maximum Working Pressure

Model	Chamber Material	Pressure at Listed Temperature in psi (bar)*					
		100°F (38°C)	200°F (93°C)	300°F (149°C)	350°F (177°C)	400°F (204°C)	450°F (232°C)
401	A106B 316SS	230 (15.8)	230 (15.8)	230 (15.8)	224 (15.4)	218 (15.0)	212 (14.6)
402	A106B 316SS	350 (24.1)	350 (24.1)	350 (24.1)	340 (23.4)	331 (22.8)	322 (22.2)
403	A106B 316SS	230 (15.8)	230 (15.8)	230 (15.8) 215 (14.8)	215 (14.8) 205 (14.1)	200 (13.7) 195 (13.4)	185 (12.7) 182 (12.5)
404	A106B 316SS	500 (34.4)	500 (34.4)	500 (34.4)	486 (33.5)	473 (32.6)	460 (31.7)
405	A106B 316SS	740 (51.0) 720 (49.6)	675 (46.5) 620 (42.7)	655 (46.1) 560 (38.6)	645 (44.4) 537 (37.0)	635 (43.7) 515 (35.5)	618 (42.6) 497 (34.2)
406	A106B 316SS	1250 (86.2)	1250 (86.2) 1240 (85.5)	1250 (86.2) 1120 (77.2)	1216 (83.8) 1075 (74.1)	1182 (81.5) 1030 (71.0)	1150 (79.3) 992 (68.4)

Minimum Specific Gravity

Model	Single Detector
401	.50
402	.90
403	.50
404	.60
405	.60
406	.60

Note: Insertion depth may affect minimum specific gravity.

*Consult the factory for pressure ratings and minimum SG of units with Monel trim



Level Detectors

Step 1b: Model Selection Pressure Rating & Specific Gravity

STEP
1b

108 A-E1A-F-A1-N4-CRTT

741-743 and 802 Displacer-operated with flanged, serviceable external chambers.

Maximum Working Pressure

Model	Chamber Material	Pressure at Listed Temperature in psi (bar)*					
		100°F (38°C)	200°F (93°C)	300°F (149°C)	350°F (177°C)	400°F (204°C)	450°F (232°C)
741	A106B	285 (19.7)	260 (17.4)	230 (15.8)	215 (14.8)	200 (13.7)	185 (12.7)
	316SS	275 (18.9)	240 (16.5)	215 (14.8)	205 (14.1)	195 (13.4)	182 (12.5)
742	A106B	740 (51.0)	680 (46.9)	655 (45.1)	645 (44.4)	635 (43.7)	618 (42.6)
	316SS	720 (49.6)	620 (42.7)	560 (38.6)	537 (37.0)	515 (35.5)	497 (34.2)
743	A106B	1480 (102.0)	1294 (89.2)	1166 (80.4)	1118 (77.1)	1070 (73.8)	1034 (71.3)
	316SS	1440 (99.3)	1240 (85.5)	1120 (77.2)	1075 (74.1)	1025 (70.7)	990 (68.3)
802	A106B	3376 (232.8)	3376 (232.8)	3270 (225.5)	3220 (222.0)	3170 (218.6)	3092 (213.2)
	316SS	3600 (248.2)	3095 (213.4)	2795 (192.7)	2683 (185.0)	2570 (177.2)	2480 (171.0)

*Consult the factory for pressure ratings of units with Monel trim. Standard displacer units are not available above 450°F (232°C). For higher temperatures up to 650°F (343°C), a special high temperature spring is available.

Minimum Specific Gravity

Model	Standard Detector	Anti-Vibration or Pneumatic Detector
741		
742	0.43	0.57
743		
802	0.41	0.5

740 and 804 Displacer-operated with sealed, tamper-proof external chambers.

Maximum Working Pressure

Model	Chamber Material	Pressure at Listed Temperature in psi (bar)*					
		100°F (38°C)	200°F (93°C)	300°F (149°C)	350°F (177°C)	400°F (204°C)	450°F (232°C)
740	A106B 316SS	1480 (102.0)	1465 (101.0)	1450 (100.0)	1436 (99.0)	1420 (97.9)	1380 (95.1)
804	A106B	3376 (232.8)	3376 (232.8)	3376 (232.8)	3376 (232.8)	3376 (232.8)	3376 (232.8)
	316SS	3728 (257.0)	3647 (251.5)	3286 (226.6)	3151 (217.3)	3016 (207.9)	2915 (201.0)

*Consult the factory for pressure ratings of units with Monel trim. Standard displacer units are not available over 450°F (232°C). For higher temperatures up to 650°F (343°C), a special high temperature spring is available.

Minimum Specific Gravity

Model	Standard Detector	Anti-Vibration or Pneumatic Detector
740	0.43	0.57
804	0.41	0.50

Level Detectors

Step 1b: Model Selection Pressure Rating & Specific Gravity

STEP
1b

108 A-E1A-F-A1-N4-CRTT

700 Series Single-stage, displacer-operated and suitable for top-insertion tank mounting
Maximum Working Pressure

Model	Minimum Specific Gravity ^{1,2,3}	Function	Connection Style	Displacer Material	Connection Material	Pressure Rating - psi (bar)	
						100°F (38°C)	450°F (232°C) ⁴
701	0.48	Narrow Differential	NPT	Porcelain	All	1000 (69)	750 (52)
702	0.43			Metallic ⁵	All	1000 (69)	750 (52)
703	0.48		Flange	Porcelain	A105	285 (20)	185 (13)
					316SS	275 (19)	182 (13)
704	0.43	Flange	Metallic ⁵	A105	285 (20)	185 (13)	
				316SS	275 (19)	182 (13)	
705	0.32	Wide Differential	NPT	Porcelain	All	1000 (69)	750 (52)
706	0.29			Metallic ⁵	All	1000 (69)	750 (52)
707	0.32		Flange	Porcelain	A105	285 (20)	185 (13)
					316SS	275 (20)	182 (13)
708	0.29		Flange	Metallic ⁵	A105	285 (20)	185 (13)
					316SS	275 (19)	182 (13)

- Notes:**
1. An operating specific gravity is required for all 705 through 708 models at time of order.
 2. Minimum SG based on standard sized displacers and units without anti-vibration, pneumatic or extra high temperature detectors.
 3. For SS displacers, lower SG's may be achieved using non-standard sized sensors.
 4. Standard displacer units are not available over 450°F (232°C). For higher temperatures up to 650°F (343°C), a special high temperature spring is available.
 5. SS will be the standard.

730 Series Dual-stage, displacer-operated and suitable for top-insertion tank mounting.
Maximum Working Pressure

Model	Minimum Specific Gravity ^{1,2,3}	Function	Connection Style	Displacer Material	Connection Material	Pressure Rating - psi (bar)	
						100°F (38°C)	450°F (232°C) ⁴
730	0.64	Narrow Differential	NPT	Porcelain	All	1000 (69)	750 (52)
731	0.57			Metallic ⁵	All	1000 (69)	750 (52)
732	0.64		Flange	Porcelain	A105	285 (20)	185 (13)
					316SS	275 (19)	182 (13)
733	0.57	Flange	Metallic ⁵	A105	285 (20)	185 (13)	
				316SS	275 (19)	182 (13)	
734	0.55	Wide Differential	NPT	Porcelain	All	1000 (69)	750 (52)
735	0.49			Metallic ⁵	All	1000 (69)	750 (52)
736	.055		Flange	Porcelain	A105	285 (20)	185 (13)
					316SS	275 (20)	182 (13)
737	0.49		Flange	Metallic ⁵	A105	285 (20)	185 (13)
					316SS	275 (19)	182 (13)

- Notes:**
1. An operating specific gravity is required for all 730 models at time of order.
 2. Minimum SG based on standard sized displacers and units without anti-vibration, pneumatic or extra high temperature detectors.
 3. For SS displacers, lower SG's may be achieved using non-standard sized sensors.
 4. Standard displacer units are not available over 450°F (232°C). For higher temperatures up to 650°F (343°C), a special high temperature spring is available.
 5. SS will be the standard.

Level Detectors

Step 1b: Model Selection Pressure Rating & Specific Gravity

STEP
1b

108 A-E1A-F-A1-N4-CRTT

750 Series Three-stage, displacer-operated and suitable for top-insertion tank mounting.
Maximum Working Pressure

Model	Minimum Specific Gravity ^{1 2 3}	Function	Connection Style	Displacer Material	Connection Material	Pressure Rating - psi (bar)		
						100°F (38°C)	450°F (232°C) ⁴	
750	0.80	Narrow Differential	NPT	Porcelain	All	1000 (69)	750 (52)	
751	0.71			Metallic ⁵	All	1000 (69)	750 (52)	
752	0.80		Flange	Porcelain	A105	285 (20)	185 (13)	
					316SS	275 (19)	182 (13)	
753	0.71			Metallic ⁵	A105	285 (20)	185 (13)	
					316SS	275 (19)	182 (13)	
754	0.85	Wide Differential		NPT	Porcelain	All	1000 (69)	750 (52)
755	0.81				Metallic ⁵	All	1000 (69)	750 (52)
756	0.85		Flange	Porcelain	A105	285 (20)	185 (13)	
					316SS	275 (20)	182 (13)	
757	0.81			Metallic ⁵	A105	285 (20)	185 (13)	
					316SS	275 (19)	182 (13)	



- Notes:**
1. An operating specific gravity is required for all 750 models at time of order.
 2. Minimum SG based on standard sized displacers and units without anti-vibration, pneumatic or extra high temperature detectors.
 3. For SS displacers, lower SG's may be achieved using non-standard sized sensors.
 4. Standard displacer units are not available over 450°F (232°C). For higher temperatures up to 650°F (343°C), a special high temperature spring is available.
 5. SS will be the standard.

108 A-E1A-F-A1-N4-CRTT

Select chamber process connection material from the following chart. Maximum working pressure shown in the charts in Step 1b is based on the material selected here. **Alternate materials can be provided, please consult the factory.**

Model	Material	Designator
All Models	A106B Carbon Steel	A
	316/316L Stainless Steel	C
	A333 GR.6 Lo-Temp Carbon Steel	F
	A335-P11 Chrome Moly*	G
	A335-P91 Chrome Moly**	P

Note: Chambered models supplied with A105 and A234-WPB fittings for Carbon steel and A182-316/316L and A403-316/316L fittings for Stainless Steel configurations.

*G Chamber/Process Connection material only available for models 103, 104, 203, 205, 206, 207 and 208.

**P Chamber/Process Connection material only available for models 205, 206 and 208

High Temperature Selection Chart

Chamber Material (Select one)	Designator	Maximum Temperature														
		0-400°F (204°C)	≤ 450°F (232°C)	≤ 500°F (260°C)	≤ 550°F (288°C)	≤ 600°F (316°C)	≤ 650°F (343°C)	≤ 700°F (371°C)	≤ 750°F (399°C)	≤ 800°F (427°C)	≤ 850°F (454°C)	≤ 900°F (482°C)	≤ 950°F (510°C)	≤ 1000°F (538°C)	≤ 1050°F (566°C)	≤ 1100°F (593°C)
A106B Carbon Steel	A	----->														
304/304LSS	Consult Factory	----->														
316/316LSS	C	----->														
A333 GR.6	F	----->														
A335-P11 Chrome Moly	G	----->														
A335-P91	P	----->														
Hastelloy C	Consult Factory	----->														
Alloy-20	Consult Factory	----->														
Monel-400	Consult Factory	----->														

Level Detectors

Step 3: Process Connection

STEP
3

108 A-E1A-F-A1-N4-CRTT

Select a process connection, size, style and rating from the charts below. Consult the factory for variations. Flanged process connections may reduce the maximum working pressure of the unit.

100 and 200 Series See page 33-36 for dimensions.

Model	Style	Size	Connection Designator				
			Standard		Flange		
			NPT Thread	Socket Weld	150# RF	300# RF	600# RF
100 Series	VH	1"	A1A	A1B	A1C	A1D	A1E
	VV		-	-	B1C	B1D	B1E
	VVD		C1A	C1B	C1C	C1D	C1E
	VVT		-	-	D1C	D1D	D1E
200 Series	VH	1-1/2"	A5A	A5B	A5C	A5D	A5E
	VV		-	-	B5C	B5D	B5E
	VVD		C5A	C5B	C5C	C5D	C5E
	VVT		-	-	D5C	D5D	D5E
	VH	2"	A2A*	A2B*	A2C	A2D	A2E
	VV		-	-	B2C	B2D	B2E
	VVD		C2A*	C2B*	C2C	C2D	C2E
	VVT		-	-	D2C	D2D	D2E

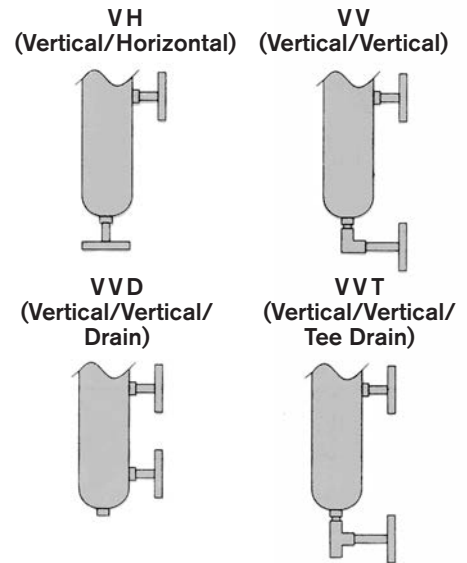

*Not available on models 121, 122, 221.

108 and 208 Series See page 37 for dimensions.

Model	Size	Style	Connection Designator
108 208	1"	NPT	E1A
		Socket Weld	E1B
	1-1/2"	NPT	E5A
		Socket Weld	E5B
	2"	NPT	E2A
		Socket Weld	E2B

NPT connections not recommended above 900°F.



300 Series See page 38 for dimensions.

Model	Size	Connection Designator			
		Standard	Flange		
		NPT Thread	150# RF	300# RF	600# RF
300 Series	1"	F1A	-	-	-
	2"	F2A	-	-	-
	3"	F3A	F3C	F3D	F3E
	4"	-	F4C	F4D	F4E
	6"	-	F6C	F6D	F6E

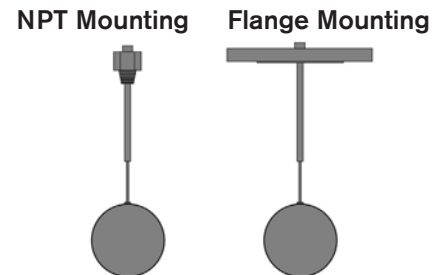

Note: It is important to consider the installation configuration when selecting the process connection. Be sure that the float will fit through the process connection, or that the vessel has access to attach the float from inside the vessel after instrument installation. See page 38 for float dimensions.

400 Series See page 39 for dimensions.

Model	Float Size	Connection Designator		
		Connection Size	Style	Designator
401	3"	3"	NPT(M) Thread	G3A
402	2-1/2"	2-1/2"	NPT(M) Thread	G7A
403	3"	3"	150# RF Weld Neck Flange	G3F
403	3"	4"	150# RF Weld Neck Flange	G4F
404	3 x 6"	3"	NPT(M) Thread	G3A
405	3 x 6"	3"	300# RF Weld Neck Flange	G3G
405	3 x 6"	4"	300# RF Weld Neck Flange	G4G
406	3 x 6"	3"	600# RF Weld Neck Flange	G3H
406	3 x 6"	4"	600# RF Weld Neck Flange	G4H

Note: 3" flanged process connections may require the float to be installed from inside the process connection.

740 Series, 741-743, 802, 804 See page 40-43 for dimensions.

Model	Style	Connection Size	Standard		Flange			
			NPT Thread	Socket Weld	150# RF	300# RF	600# RF	1500# RTJ
740 741-743 802 804	VH	1"	A1A	A1B	A1C	A1D	A1E	A1T
	VV		-	-	B1C	B1D	B1E	B1T
	VVD		C1A	C1B	C1C	C1D	C1E	C1T
	VVT		-	-	D1C	D1D	D1E	D1T
	VH	1-1/2"	A5A	A5B	A5C	A5D	A5E	A5T
	VV		-	-	B5C	B5D	B5E	B5T
	VVD		C5A	C5B	C5C	C5D	C5E	C5T
	VVT		-	-	D5C	D5D	D5E	D5T
	VH	2"	A2A*	A2B*	A2C	A2D	A2E	A2T
	VV		-	-	B2C	B2D	B2E	B2T
	VVD		C2A*	C2B*	C2C	C2D	C2E	C2T
	VVT		-	-	D2C	D2D	D2E	D2T

*Not available on Models 740, 741, 742, and 743.

Note: Flanged process connections may reduce the maximum working pressure of the unit.

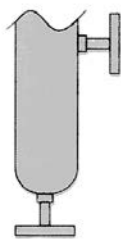

VH
(Vertical/Horizontal)

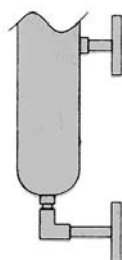

VV
(Vertical/Vertical)

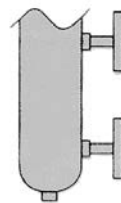

VVD
(Vertical/Vertical/Drain)



VVT
(Vertical/Vertical/Tee Drain)

700, 730 and 750 Series See page 44-46 for dimensions.

Model	Connection Size	Style	Connection Designator
701	2-1/2"	NPT	F7A
702			
705			
706			
730			
731			
734	3"	NPT	F3A
735			
750			
751			
754			
755			
703	3"	150# RF Flange	F3C
704		300# RF Flange	F3D
707	4"	150# RF Flange	F4C
708		300# RF Flange	F4D
732		150# RF Flange	F4C
733		300# RF Flange	F4D
736	6"	150# RF Flange	F6C
737		300# RF Flange	F6D
752		150# RF Flange	F6C
753		300# RF Flange	F6D
756	6"	150# RF Flange	F6C
757		300# RF Flange	F6D

Note: Flanged process connections may reduce the maximum working pressure of the unit.

Level Detectors

Step 4: Trim Material

STEP
4

108 A-E1A-E-A1-N4-CRTT

Select the internal trim material from the chart below.

Model	Float/Displacer Material	Attraction Sleeve Material	Available with Chamber Material	Trim Designator
100 Series 200 Series 300 Series 400 Series 741-743 802 740, 804	316/316L SS	400 SS	A106 Carbon Steel (A) only	B
	316/316L SS	316/316L SS	A106 Carbon Steel (A) or 316/316L SS (C)	C
	Monel 400	Monel 400	A106 Carbon Steel (A) or 316/316L SS (C)	M
108 208	321 SS	400 SS	A106 Carbon Steel (A) only	F
	321 SS	316/316L SS	A106 Carbon Steel (A) or 316/316L SS (C)	G
702 704 706 708 731 733 735 737 751 753 755 757	316/316L SS	400 SS	A106 Carbon Steel (A) only	B
	316/316L SS	316/316L SS	A106 Carbon Steel (A) or 316/316L SS (C)	C
702 704 706 708 731 733 735 737 751 753 755 757	Hollow Brass	316/316L SS	A106 Carbon Steel (A) or 316/316L SS (C)	D
	Solid Brass	316/316L SS	A106 Carbon Steel (A) or 316/316L SS (C)	E
	Solid Rubber	316/316L SS	A106 Carbon Steel (A) or 316/316L SS (C)	F
701 703 705 707 730 732 734 736 750 752 754 756	Porcelain	400 SS	A106 Carbon Steel (A) only	P
	Porcelain	316/316L SS	A106 Carbon Steel (A) or 316/316L SS (C)	R

Note: Consult the factory for pressure ratings on Monel trim. Standard displacer spring material is Inconel 600.

SOR detecting mechanisms are designed for use in harsh industrial atmospheres. SOR offers a variety of electrical and pneumatic detecting mechanism types to fit a wide range of applications. The basic types of detector mechanisms available are listed below. See page 20 for specifications.

All SOR detecting mechanisms are constructed from stainless steel and other durable manufactured materials. Each mechanism is individually calibrated and inspected to insure accuracy and repeatability. See below for the benefits and application of each detector type. All mechanisms are interchangeable with most competitor units.

Types A, B, C, E; Standard Dry-Contact Action Elements



Standard dry-contact detectors have open mechanisms and exposed detecting elements. These detecting mechanisms are easy to maintain. Visual confirmation of operation is obvious. Dry-contact detector mechanisms are recommended for most level detector applications and are available in SPDT and DPDT detector arrangements.

- High-load carrying capacity
- High-quality phenolic insulator
- Vibration resistance
- Versatility of application

Types F, G, H; Hermetically Sealed Action Elements



Hermetically sealed detectors are entirely enclosed in a hermetically sealed enclosure. Both detecting elements and mechanisms are sealed. Good for volatile atmospheres and low temperatures.

- Completely enclosed detecting mechanism and detector contacts
- Long-term reliability in harsh environmental conditions
- Vibration resistance

Types L, S, T, V; Mini-Hermetically Sealed Action Elements

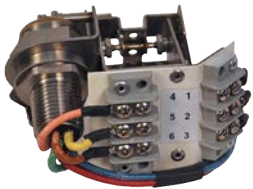

Mini-hermetically sealed detectors have a hermetically sealed detector element on an exposed mechanism. Good for high-temperature service and normal applications that require hermetically sealed contacts.

- Rugged stainless steel construction
- Class I Group A rating for use in hazardous areas
- Vibration resistance
- High operating temperature limits

Types D and R; Anti-Vibration Action Elements

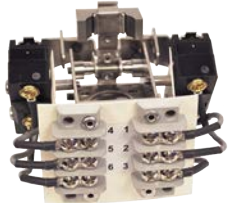

Anti-Vibration Detectors employ two magnets to provide vibration protection. Dual magnets prevent false trips by providing a positive mechanical lock to the enclosing tube when the detector is in any position. (Type T detectors are mini-hermetically sealed units with dual magnets.)

Type J; Pneumatic Action Elements



Pneumatic detectors are available for applications that prohibit electrical detecting or where electricity is not available.

- Three-way aluminum valve
- Anti-vibration design
- 1/4" NPT ports in 316SS for additional corrosion resistance

Type Y; Extra-High Temperature Action Elements

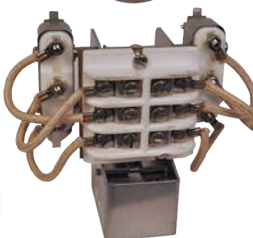

The Y Series level detector mechanism is designed to operate normally under extremely high-temperature conditions. Constructed of stainless steel, ceramic, and oxidation-resistant alloys, the Y Series is designed to counteract the warping and seizure normally associated with this type of mechanism in high temperatures. The Y Series detector is especially well suited for power plant conditions.

- Mica/glass insulation on wires and detectors
- Stainless steel and ceramic detector element and terminal block
- Detector mechanism rated at 800°F (427°C) continuous process temperature
- Can be combined with external temperature protection to function in temperatures up to 1200°F (649°C)
- Dual magnets for vibration protection

Detector Designator		Resistive Amperage					Inductive Amperage					Minimum Temperature ¹	Maximum Temperature ²
		110-130VAC	210-250VAC	20-30VDC	110-130VDC	210-250VDC	110-130VAC	210-250VAC	20-30VDC	110-130VDC	210-250VDC		
A	Standard Dry Contact	15	15	5	.5	.25	15	15	5	.4	.13	-15°F (-26°C)	250°F (121°C)
B	Hi-Temperature Dry Contact	5	5	1.5	.5	-	5	5	1	.25	-	-15°F (-26°C)	400°F (204°C)
C	Gold Contact	1	-	1	-	-	1	-	.5	-	-	-15°F (-26°C)	250°F (121°C)
D	Anti-Vibration	15	15	5	.5	.25	15	15	5	.4	.13	-15°F (-26°C)	250°F (121°C)
E	High-Amp DC	-	-	10	10	3	-	-	10	10	3	-15°F (-26°C)	250°F (121°C)
F	Hermetically Sealed	11	11	5	.5	.25	11	11	.25	.25	.13	-65°F (-54°C)	250°F (121°C)
G ⁷	Gold Contact Hermetically Sealed	1	-	1	-	-	1	-	.5	-	-	-65°F (-54°C)	250°F (121°C)
H	High-Temperature Hermetically Sealed	5	5	1.5	.3	-	5	5	1	.25	-	-65°F (-54°C)	350°F (177°C)
L ⁵	Mini-Hermetically Sealed	DPDT	5	5	5	.5	-	5	5	2.5	.25	-15°F (-26°C)	250°F (121°C)
		SPDT	11	11	5	.5	.25	11	11	2.5	.25		
R	Anti-Vibration Gold Contact	1	-	1	-	-	1	-	.5	-	-	-15°F (-26°C)	250°F (121°C)
S ⁷	Gold Contact Mini-Hermet	1	-	1	-	-	1	-	.5	-	-	-15°F (-26°C)	250°F (121°C)
T ⁵	Anti-Vibration Mini-Hermet	DPDT	5	5	5	.5	-	5	5	2.5	.25	-15°F (-26°C)	250°F (121°C)
		SPDT	11	11	5	.5	.25	11	11	2.5	.5		
V ⁷	High-Temperature Mini-Hermet	5	5	1.5	.5	-	5	5	1	.25	-	-15°F (-26°C)	400°F (204°C)
Y ⁶	Extra-High Temperature (Ceramic)	1	1	1	.4	-	1	1	.4	-	-	-40°F (-40°C) Note 3	800°F (427°C)
J ⁴	Pneumatic 316SS Fittings	Non-bleed 3-way aluminum valve body. Buna-N O-Rings 150 psi maximum supply, 24CFM @ 100 psi										5°F (-15°C)	200°F (93°C)

Notes

1. Minimum ambient temperature at which the detector mechanism will operate normally. This may vary according to actual climatic conditions. Actual minimum process temperature may be much lower. Consult the factory for details.
2. Maximum process temperature at which the detector mechanism will operate normally. This can be increased according to the type of process. Refer to pages 25-26 for more details.
3. -40°F Temperature rating with no icing.
4. Pneumatic detectors must be used with clean, dry air or gas.
5. These detector designators have higher current rating for SPDT than DPDT.
6. Manufacturer specifications state maximum operating humidity must be <85% and minimum power rating is 100mW.
7. For high humidity environments and low current (<100mA), use hermetically sealed gold contact detectors (S & G detectors). For high temperatures, high humidity, and low current, a "V" detector is available with gold contacts upon request.

Select the detector mechanism from the chart below. See page 20 for contact and temperature ratings.

Detector Type	SPDT Single Pole Double Throw			DPDT Double Pole Double Throw			3-Way Valve	Available Agency Listings						
	Single	Dual	Triple	Single	Dual	Triple	Single	CSA	UL	ATEX/IECEx (flameproof)	ATEX/IECEx (IS)	INMETRO (flameproof)	INMETRO (IS)	Rostechnadzor (RTN)
Detecting Stages														
Detecting Description	Designator													
Standard Dry Contact	A1	A2	A3	A4	A5	A8	-	•	•	•		•		•
High-Temperature Dry Contact	B1	B2	B3	B4	B5	B8	-	•	•	•		•		•
Gold Contact	C1	C2	C3	C4	C5	C8	-	•	•	•	•	•	•	•
Anti-Vibration Dry Contact ¹	D1 ¹	-	-	D4 ¹	-	-	-	•	•	•		•		•
High-Amperage DC Service	E1	E2	E3	E4	E5	E8	-	•	•	•		•		•
Hermetically Sealed	F1	F2	F3	F4	F5	F8	-	•	•	•		•		•
Gold Contact Hermetically Sealed	G1	G2	G3	G4	G5	G8	-	•	•	•	•	•	•	•
High-Temperature Hermetically Sealed	H1	H2	H3	H4	H5	H8	-	•	•	•		•		•
Standard Mini-Hermetically Sealed	L1	L2	L3	L4	L5	L8	-	•	•	•		•		•
Anti-Vibration Gold Contact ¹	R1 ¹	-	-	R4 ¹	-	-	-	•	•	•	•	•	•	•
Gold Contact Mini-Hermet	S1	S2	S3	S4	S5	S8	-	•	•	•	•	•	•	•
Anti-Vibration Mini-Hermet ¹	T1 ¹	-	-	T4 ¹	-	-	-	•	•	•		•		•
High-Temperature Mini-Hermet	V1	V2	V3	V4	V5	V8	-	•	•	•		•		•
Extra-High Temperature (Ceramic) Pneumatic Non-Bleed with 316SS Fittings	Y1 ¹	-	-	Y4 ¹	-	-	-	•	•	•	•	•	•	•
	-	-	-	-	-	-	JO ^{1,2}							
Available with models:														
100-200-300-740-800 Series	•	•		•	•		•	•	•	•	•	•	•	•
108/208-400 Series	•			•			•	•	•	•	•	•	•	•
700 Series	•			•			•	•	•	•	•	•	•	•
730		•			•			•	•	•	•	•	•	•
750 (enclosures N1, N8 or B5 only)			•			•		•						•

Notes

1. These detectors use two magnets and must be considered dual mechanisms when figuring minimum specific gravity.
2. Pneumatic detecting mechanisms must be specified with P1 housing.

Level Detectors

Step 6: Housing

108 A-E1A-F-A1-N4-CRTT

SOR housings are designed to protect the detecting mechanisms from harsh environmental conditions, as well as protecting the surrounding atmosphere from potential ignition sources. The basic types of housings are listed below.

General Purpose, NEMA 4x Housings

- Heavy duty cast aluminum
- All housings are rated NEMA 4x (IP66) as a minimum

Explosion-Proof Housings

- Available in aluminum or cast iron
- Ratings as shown in chart below

Pneumatic Detector Housings

- Required for use with a pneumatic detecting mechanism
- General Purpose, NEMA 4 (IP66) only



Detector Housings

Select the housings from the chart below

Housing Designator	Description	Electical/ Pneumatic Connections	Enclosure Rating ²	Approvals						Available with Models					
				Canada	USA	ATEX	IECEX	Rostechnadzor	INMETRO	100, 200, 300	108, 208, 400	740, 800	700's	730's	750's
B1	Aluminum	1" NPT	Groups B C D E F G	■	■			○		○	○	○	○	○	
B2	Cast Iron		Groups B C D E F G	■	■			○		○	○	○	○	○	
B5 ²	Aluminum Extended		Groups B C D E F G	■	■			○							○
N1	Aluminum Extended		NEMA 4, 4X	■				○							○
N4	Aluminum		NEMA 4, 4X	○	■			○		○	○	○	○	○	
N7	Aluminum		Groups C D F G	■	■			○		○	○	○	○	○	
N8	Aluminum Extended		Groups C D E F G	■	■			○							○
P1 ¹	Aluminum Pneumatic		(3) 1/4" NPT	NEMA 4, 4X							○	○	○	○	
S3	Aluminum	1" NPT ³	Ex d IIC T6 Gb			○	■	○	○	○	○	○	○	○	
S8	Cast Iron		Ex d IIC T6				■	○		○	○	○	○	○	
T6	Cast Iron		Ex d IIC T6 Gb			■	■	○		○	○	○	○	○	

- — Available
- — Standard

Notes:

1. P1 housing must be used with pneumatic detector mechanisms.
2. B5 housing is rated for Groups B C D E F G in Canada, and Groups C D F G in the USA.
3. For M20 x 1.5 connection size, add Accessory Designator CN to the end of the SOR level detector model number.

Level Detectors

Step 7: Accessories/Certificates

108 A-E1A-F-A1-N4-CRTT

SOR accessories are provided for customizing the level detectors in this catalog according to the requirements of the application. Place accessory designator(s) from the table below at the end of the model number. Check the compatibility chart below for correct use of each accessory.

Accessory Designator	Description	Model Series									
		100	200	108/208	300	400	741-743/802	740/804	700	730	750
AF ¹ CL	Air Filter & Gauge ATEX/IECEx Approval for S3 Hsg	●	●	●	●	●	●	●	●	●	●
CN CP CR	Conduit Reducer M20 x 1.5 Conduit Reducer 1/2" NPT Conduit Reducer 3/4" NPT	●	●	●	●	●	●	●	●	●	●
CS ² CV ³ CY	CSA Certification Canadian Registration Number (CRN) Certificate of Conformance (Power Piping, ASME 31.1)	●	●	●	●	●	●	●	●	●	●
CZ ⁴ DN EC ⁵	Certificate of Conformance (Process Piping, ASME 31.3) Special Drain Connection Extra Chamber Connection	●	●	●		●	●	●			
ET ⁶ FE ⁶ FF GG	Temperature Extension Finned Extension Convert Facing Flat Face Flange Sealed Conduit	●	●	●	●	●	●	●	●	●	●
ID ⁷ KK MC ⁸	Interface Detection Housing Breather Drain Manual Check	●	●	●	●	●	●	●	●	●	●
MR MT ⁹ NC NM	Mill Test Report Mag Particle Examination NACE Construction INMETRO Approved for S3 Hsg	●	●	●	●	●	●	●	●	●	●
PD PP PT PY RR	Certificate of compliance/conformance to EU Directive 2014/68/EU (PED) Fiber Tag Dye Penetration Examination Powder coat epoxy coating. No coating on stainless steel parts or plated screws. (500 hrs. salt spray) SS Tag wired to housing	●	●	●	●	●	●	●	●	●	●
RT SC ¹⁰ SD ¹¹	Radiograph Examination Special Calibration Special Dimensions	●	●	●	●	●	●	●	●	●	●
SL ¹² TC ⁸	Special Cable Length Tru-Check								●	●	●
TF TS ¹³ TT TW	Tandem Floats Taiwan Safety Mark Oversized Nameplate for customer tagging Top Works Only (no chamber)	C/F	C/F		●	●	●	●	●	●	●
UT VV WC WN WV ²	Ultrasonic Examination Fungicidal Varnish Water Column Unit Convert to Weld Neck Flange UL Listed	●	●	●	●	●	●	●	●	●	●
YY	Epoxy Coating (enclosure only)	●	●	●	●	●	●	●	●	●	●

Notes:

- C/F = Consult the Factory
- 1. Pneumatic detecting mechanisms only (P1)
- 2. Consult detector and housing sections for agency availability.
- 3. CY or CZ option may be required for CRN, see Page 24.
- 4. Process media must be known prior to manufacture. Different processes (service categories) require different quality inspection procedures. Consult the factory for details.
- 5. Need connection size, type, and location on chamber.
- 6. See high-temperature selection for application, Pages 26-27.
- 7. The upper & lower specific gravity required to determine functionality.
- 8. Appropriate for Model Series 701 through 704 & 730 through 733. See page 28 for details. Not available with NACE.
- 9. No MT option on Stainless Steel
- 10. Operating specific gravity, Set Point (referenced from upper process connection) and if Set Point is rising or falling are required.
- 11. Specific details of chamber dimensional changes.
- 12. Length of cable required (10 ft. is standard).
- 13. Requires S3, S8 or T6 Housing.

Test Certificates

Model Series	Certificate Designator	Calibration	Hydrostatic Pressure Test	Inspection Report	Compliance /Conformance	Dielectric Test	Insulation Resistance	QA Test Report	Certificate of Origin	Manufacturer's Certification	
100	D1								◆		
	D2									◆	
	C1	◆									
	C2		◆								
	C3			◆							
	C4					◆					
	C5						◆				
	C6							◆			
	C7								◆		
	200										
	300	B2	◆	◆	◆				◆		
	300	B3	◆	◆	◆	◆			◆		
	400	B5	◆		◆		◆	◆			
	108/208	B6	◆		◆			◆			
		B7	◆		◆	◆					
		A2	◆	◆		◆					
		A3	◆	◆	◆						
		A4	◆	◆	◆	◆					
		A7	◆	◆	◆		◆	◆			
A8		◆	◆	◆	◆		◆				
A9		◆	◆	◆	◆		◆	◆			
700		C1	◆								
730	C3			◆							
750	C4				◆						
*740, 804	C5					◆					
741-743	C6						◆				
802	C7							◆			
*These products also have Certificate C2 - Hydrostatic Pressure Test.	B5	◆		◆		◆	◆				
	B6	◆		◆			◆				
	B7	◆		◆	◆						

Canadian Registration Number OH0690

Model Series	Chamber/Process Connection Material	Process Connection Size & Type	Trim Material	Detecting Mechanism	Housing	Accessories
100 200 108/208	ALL	ALL	ALL	ALL	ALL	CV & CY or CV & CZ Required*
300	ALL	ALL	ALL	ALL	ALL	CV Required
400 741-743, 802 740, 804	ALL	ALL	ALL	ALL	ALL	CV & CY or CV & CZ Required*
700 730 750	ALL	ALL	ALL	ALL	ALL	CV Required

*See page 29 for CY and CZ information.

SOR level detectors can accommodate high-temperature applications up to 1200°F (649°C). These temperatures may be safely reached by a proper combination of chamber material, detector mechanism and temperature extension. Refer to page 26 to select the proper components for your process temperature.

ET Accessory

The straight temperature extension provides physical distance between the process and the detecting mechanism. It is constructed of a straight piece of pipe welded between the chamber and enclosing tube connection.

How It Works

The straight temperature extension is designed to remove the detector from direct radiant heat in dry heat processes. Consult the chart on page 26 for application.

To Specify

Add Accessory Designator ET to the end of the SOR level detector model number per the selection chart on page 26.

The ET accessory automatically matches the material and rating of the specified level detector chamber. This option can be supplied on SOR level detectors 100, 200, 300 and 400 Series.

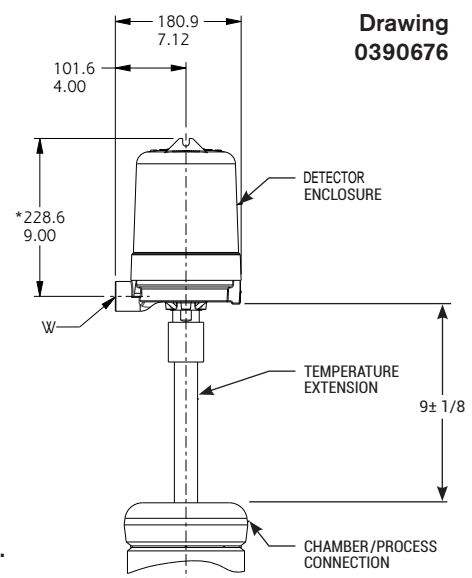

FE Accessories

The finned temperature extension is designed to protect the electrical portion of a level detector from heat damage due to condensing processes. When used in combination with high-temperature detector mechanisms, this option allows operation in process temperatures up to 1200°F (649°C).

How It Works

The finned temperature extension condenses process steam and reduces its heat before it can reach the detecting mechanism. The design reduces steam to its saturation temperature in the enclosing tube, protecting the detecting mechanism from deterioration due to high temperatures. The process pressure dictates the saturation temperature, see page 32.

To Specify

Add Accessory Designator FE to the end of the SOR level detector model number per the selection chart on page 26.

The finned temperature extension automatically matches the material and rating of the specified level detector chamber. These options can be supplied on SOR level detectors 100, 200, 108/208, 300 and 400 Series.

Note: For proper cooling, temperature extensions must not be insulated or placed inside an enclosed structure. High ambient temperatures (over 100°F/38°C), intense direct sunlight, or heat loading from adjacent piping or vessels will affect cooling performance. Consult the factory if any of these conditions exist.

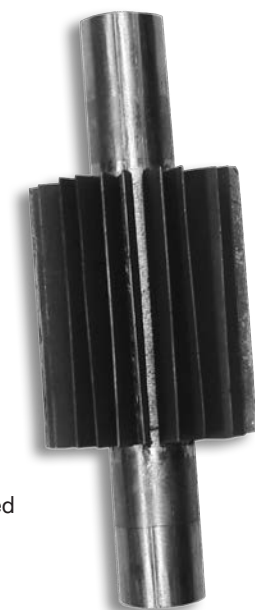

Fundamental differences in condensing (steam) and non-condensing (dry) heat require different methods of protection.

Steam Heat processes carry it's heat with the vapor. These processes effectively heat every portion of their enclosure. To reduce the heat effects of condensing processes, we must either condense or physically block the vapor. SOR uses a condensing system to avoid the sealing problems associated with blocking the steam.

Dry Heat processes transfer heat through direct conduction. Heat is only passed to the areas where they touch the enclosure. Therefore, radiant heat is the only concern with these processes. This may be resolved by adding distance between the process and the protected portion of the control.

Using the charts below, find your desired maximum temperature and select a corresponding chamber material. In the process type chart, select a detector mechanism based on whether you are using Steam Heat or Dry Heat. The symbol will indicate if a temperature reduction device is required.

High Temperature Selection Chart

Chamber Material (Select one)	Designator	Maximum Temperature																
		0-400°F (204°C)	≤ 450°F (232°C)	≤ 500°F (260°C)	≤ 550°F (288°C)	≤ 600°F (316°C)	≤ 650°F (343°C)	≤ 700°F (371°C)	≤ 750°F (399°C)	≤ 800°F (427°C)	≤ 850°F (454°C)	≤ 900°F (482°C)	≤ 950°F (510°C)	≤ 1000°F (538°C)	≤ 1050°F (566°C)	≤ 1100°F (593°C)	≤ 1150°F (621°C)	≤ 1200°F (649°C)
A106B Carbon Steel	A																	
304/304LSS	Consult Factory																	
316/316LSS	C																	
A333 GR.6	F																	
A335-P11 Chrome Moly	G																	
A335-P91	P																	
Hastelloy C	Consult Factory																	
Alloy-20	Consult Factory																	
Monel-400	Consult Factory																	

Heat Type

Steam Heat Applications - Detector Mechanism (Select one)

Hi-Temp Dry Contact or Mini-Hermet	B/V	■	●	●	❖	❖												
Hi-Temperature Ceramic/SS	Y	■	■	■	■	■	■	■	■	■	❖	❖	❖	❖	❖	❖	❖	❖

Dry Heat Applications - Detector Mechanism (Select one)

Hi-Temp Mini-Hermet or Dry Contact	B/V	■	●	●	●	●												
Hi-Temperature Ceramic/SS	Y	■	■	■	■	■	■	■	■	■	●	●	●	●				

For proper cooling, temperature extensions and finned extensions must not be insulated or placed inside an enclosed structure. High ambient temperatures (over 100°F/38°C), intense direct sunlight or heat loading from adjacent piping or vessels will affect cooling performance. Consult the factory if any of these conditions exist.

■ = Detector Only ❖ = Finned Extension ● = Temperature Extension

Float Detector Pressure Ratings (in psi) above 450°F (232°C). Higher temperatures available with other materials. Consult factory.

Model	Material	Pressure at Listed Temperature in psi					
		500°F (260°C)	550°F (288°C)	600°F (316°C)	650°F (343°C)	700°F (371°C)	750°F (399°C)
101	CS & SS	170	155	140	125	110	95
102	CS & SS	447	435	423	411	400	389
103	CS	600	575	550	535	535	505
	SS	480	465	450	445	430	425
104	CS & SS	894	870	846	823	800	778
108	CS	600	575	550	535	535	505
	SS	480	465	450	445	430	425
109	CS & SS	170	155	140	125	110	95
121	CS & SS	170	155	140	125	110	95
122	CS & SS	313	304	296	288	280	272
201	CS & SS	201	196	190	185	180	175
202	CS & SS	268	261	254	247	240	233
203	CS & SS	447	435	423	411	400	389
204	CS & SS	1118	1087	1057	1029	1000	972
205	CS & SS	671	652	634	617	600	584
206	CS & SS	894	870	846	823	800	778
207	CS & SS	894	870	846	823	800	778
208	CS	1794	1794	1794	1794	1722	1554
	SS	1495	1453	1411	1387	1351	1339
209	CS & SS	403	391	381	370	360	350
221	CS & SS	313	304	296	288	280	272

CS = A106B Carbon Steel

SS = 316/316L Stainless Steel

Level Detectors

MC AND TC OPTIONS

Manual Check (MC) and Tru-Check (TC) options permit manual actuation of vertical displacer level detectors, addressing EPA and OSHA safety requirements. The standard 30-foot stainless steel chain allows manual actuation from the tank base, eliminating potentially hazardous trips to the top of the tank. Specify either an MC or TC option by placing the designator in the accessory section of the model number.

Designator	Application
TC	Tanks or vessels pressurized to 100 psi
MC	Atmospheric vented tanks or vessels

These options are available on SOR level detector Series 701 through 704 and 730 through 733. MC and TC option available on carbon steel units only. Series 730 through 733 are more sensitive to both high and low SG values. Please consult factory before ordering the MC or TC options for these models.

How It Works

Pulling the handle transfers downward motion to the actuator lever by means of the beaded stainless steel chain. The resultant motion lifts the entire level sensing assembly which moves the attraction sleeve and actuates the detecting element to simulate a high-level condition. Detecting action for alarm, shutdown or control is verified.

Dimensions

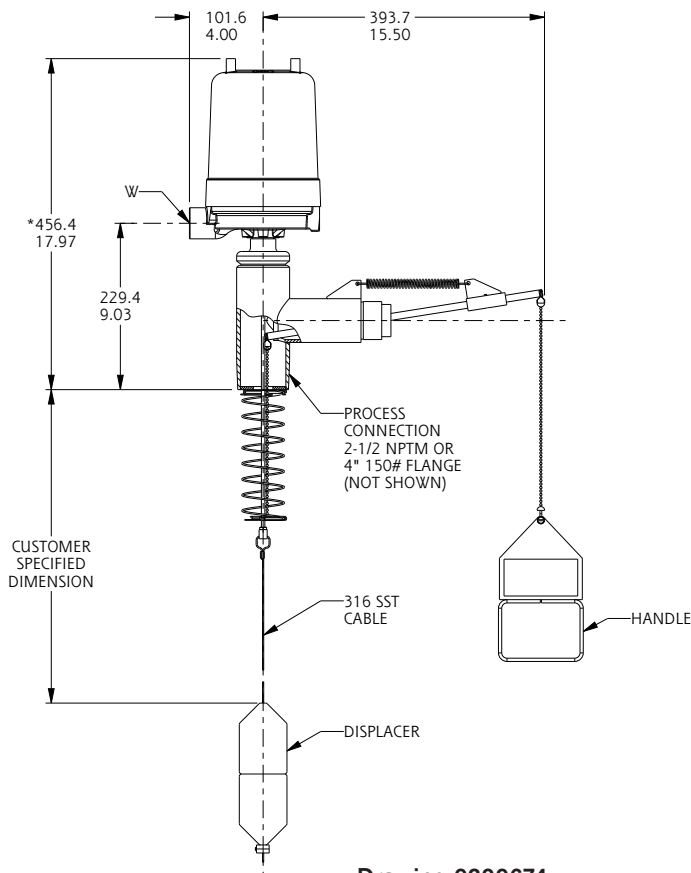

Drawing 0390674

Product Specifications

Pressure Range

TC (Tru-Check)	*0 to 100 psi
MC (Manual Check)	0 psi (vented to atmosphere)

*Maximum pressure for entire level sensing assembly is 100 psi with Tru-Check installed.

Temperature Range -40 to 300°F (-40 to 150°C)

Wetted Parts

Ball	Chrome Plated Brass
Seal	Teflon
Spring	Spring Steel
Body	1018 Steel

Design and specifications are subject to change without notice. For latest revision, see www.sorinc.com.

Specify either a CY or CZ option in the accessory section of the model number for a certificate of conformance.

Designator	Certificate of Conformance to
CY	ASME B31.1 Power Piping
CZ	ASME B31.3 Process Piping
PD	EU Directive 2014/68/EU (PED)

If certification to B31.3 is required, SOR Inc. must know the fluid category per the chart below. Read the ASME B31.3 Fluid Category Section at the bottom of this page to determine the applicable category. If no category is selected normal category will be assumed.

Units Covered	Visual Examination ¹	Radiographic (X-Ray) RT	Magnetic Particle MT	Dye Penetrant PT	Hydrotest
Standard Inspection					
All Chambers	100%	0%	0%	0%	1.5 x pressure for 3 minutes
CY Option (ASME B31.1)					
Below 750°F Below 1025 psi	100%	-	-	-	1.5 x pressure for 10 minutes
Below 350°F All pressures	100%	-	-	-	
350°F - 750°F Above 1025 psi	100%	All butt welds $\geq 2"$	-	-	
Above 750°F All pressures	100%	All butt welds $\geq 2"$	Butt welds $\geq 2"$ all other welds	Butt welds $\geq 2"$ all other welds	
CZ Option (ASME B31.3)					
Normal Fluid	5%	5% ²	-	-	1.5 x pressure for 10 minutes
Category D	Engineering/QA Choice	-	-	-	
Category M	100%	20% of all welds ³	-	-	
High Pressure	100%	100% of girth/branch welds	-	-	

Notes

1. In process visual inspection: inspecting pipe bevel prior to welding, check fit-up, check after-tack weld, and check during weld passes. After completion visual inspection: welding and grinding is checked.
2. In process examination may be substituted on a weld-for-weld basis.
3. In process examination supplemented by appropriate NDE (MT or PT) may be substituted on a weld-for-weld basis.

ASME B31.3 Fluid Category

Normal	A fluid service not subject to the following four categories.
Category D	A fluid service in which all of the following apply: <ol style="list-style-type: none"> 1. The fluid handled is non-flammable, non-toxic, and not damaging to human skin. 2. The design gage pressure does not exceed 150 psi. 3. The design temperature is between -20°F and 366°F.
Category M	A fluid service in which the potential for personnel exposure is judged to be significant and in which a single exposure to a very small quantity of a toxic fluid, caused by leakage, can produce serious irreversible harm to persons on breathing or bodily contact, even when prompt restorative measures are taken.
High Pressure	Pressure in excess of that allowed by the ASME B16.5 Class 2500 rating for the specified temperature and material group or any piping so designated by the customer.

Pressure Equipment Directive (PED) – Directive 2014/68/EU

If PED is required, SOR inc must know the following to determine EPR Category of the unit.

1. Design Pressure.
2. Design Temperature Range.
3. Process Fluid Group.
4. Design Code. Unless otherwise required by the Customer, ASME Section VIII will be the default design code.

Notes

- All units being certified to either PED will also require Material Certificates (MR) and Hydrostatic Test (C2)
- For B31.3 construction and PED compliance, in-process weld inspection will be performed to meet B31.3 requirements.
- If the X-Ray is requested, this will be done in addition to the in-process weld inspection. Since this X-Ray would be a customer requirement and not a design code requirement, SOR can use any approved Vendor for this NDE. For B31.3 Category M PT (in addition to in-process weld inspection) will be substituted in lieu of X-ray inspection. MT may be substituted when the unit's construction is Carbon Steel.

Standard Inspection & Testing Certifications

SOR level detectors are available with a wide selection of optional inspection and testing certifications. The section below specifies the SOR standard offering for each option, however inspection and testing can also be provided to meet your specific alternative requirements. Consult the factory for details.

PMI Report	Alloy verification of wetted parts using x-ray fluorescence (XRF) technology to positively identify the part material used post manufacturing.
Hydrostatic Pressure Test	Process conforms to ASME Section V and is conducted per serial number. If valves are used, hydro testing will be done with valve open and ports plugged.
Visual Inspection Report	Visual weld inspection by certified weld inspector per sales order line item.
Factory Acceptance Test	Summary of testing schedule completed per sales order line item.
Inspection Test Plan	Summary of all the testing processes that will be conducted per sales order line item.
Mill Test Report	Certifies that the listed serial numbers were manufactured using the material on the associated Certified Material Test Reports (CMTR).
Dye Penetrant Examination	Certifies that the listed serial numbers were examined by visible liquid penetrant in accordance with ASME Section V, Article 6.
NACE Compliance	SOR shall provide certification of compliance that the pressure boundary components of the listed serial numbers were manufactured to meet NACE MR0175/ ISO15156.
Ferrite Test	Certifies the Ferrite Number (FN) of 20% of the welds per serial number is documented on associated weld map drawings.
Radiographic Examination (X-Ray)	Certifies the 3rd party radiographic examination of 5% of welds per sales order line item by sample size in accordance with ASME Section V.
Heat Treat	Certifies heat treatment was conducted to ASTM standards per sales order line item.
Mag Particle Examination	Certifies that the listed serial numbers were examined by visible mag particle in accordance with ASME Section V.
Ultrasonic Examination	Certifies that the listed serial numbers were examined by 3rd party ultra sonic examination in accordance with ASME Section V.

Designator	Material	ASTM Spec-Grade	ASME B16.9	ASME 16.11	ASME B16.5	Temperature Range
		Seamless Pipe	Wrought Butt Weld Fitting	Forged Fittings SW/Threaded	Pipe Flanges	
A	Carbon Steel	A106B	A234-WPB	A105	A105	-20°F to 800°F
B	304/304LSS	A213-TP304	A403-WP304	A182-F304	A182-F304	-425°F to 1000°F
C	316/316LSS	A213-TP316	A403-WP316	A182-F316	A182-F316	-425°F to 1000°F
D	Duplex SS	A-790	A-815	A182-F51	A182-F51	-60°F to 600°F
E	2-1/4% Chrome 1% Moly	A335-P22	A335-WP22	A182-F22	A182-F22	-20°F to 1100°F
F	Low Temperature Carbon Steel	A333 Gr. 6	A420-WPL6	A350-LF2	A350-LF2	-50°F to 700°F
G	1-1/4% Chrome 1/2% Moly	A335-P11	A234-WP11	A182-F11	A182-F11	-20°F to 1100°F
H	Hastelloy-C276 N10276	B6221	B366/B564	B366/B564	B366/B564	-325°F to 800°F
J	321SS	A213-TP321	A403-WP321	A182-F321	A182-F321	-425°F to 1000°F
K	347SS	A213-TP347	A403-WP347	A182-F347	A182-F347	-425°F to 1000°F
L	Alloy-20 N08020	B4641	B366/B962	B366/B462	B366/B462	-325°F to 800°F
M	Monel 400 N04400	B-1651	B366	B564	Gr N0 4400 B564	-325°F to 900°F
N	5% Chrome 1/2% Moly	A335-P5	A234-WP5	A182-F5	A182-F5	-20°F to 2500°F
P	316/316HSS	A213-TP316H	A403-WP316H	A182-F316H	A182-F316H	-325°F to 2500°F
Q	9% Chrome 1% Moly	A335-P9	A234-WP91	A182-F9	A182-F9	-20°F to 2500°F
S	9% Chrome 1% Moly Vanadium	A335-P91	A234-WP91	A182-F91	A182-F91	-20°F to 1200°F
T	304HSS	A213-TP304H	A403-WP304H	A182-F304H	A182-F304H	-325°F to 2500°F
U	Inconel 600 N06600	B1671	B366	B564	B564	-325°F to 2500°F
W	Inconel 625 N06625	B7041	B366	B564	B564	-325°F to 1200°F
Y	317SS	A213-TP317	A234-WP317	A182-F316	A182-F317	-325°F to 1000°F

Flange Face Finishes

The most common flange face finishes are shown in the table below.

Raised Face Flanges (RF)

All raised-face flange finishes are given as a range. AARH (Average Arithmetic Root Height) values are given with their metric equivalent.

AARH (μin.)	1000-2000	500-1000	250-500	125-250	63-125	32-63	16-32
Ra (μm)	25-50	12.5-25	6.3-12.5	3.2-6.3	1.6-3.2	0.8-1.6	0.4-0.8

Ring Tight Joint Flanges (RTJ)

The side surfaces of RTJ gasket surfaces shall not exceed 63μ" (1.6μm) roughness per ANSI B16.5.

The approximate shipping weights shown below are for standard models. Weights will vary based on pipe size, length and flange size. Consult the factory for the weight of a specific unit.

Floats				Displacers			
Model	pounds	kilograms	Page	Model	pounds	kilograms	Page
101*	55	25	33	701	18	8.5	44
102*	80	37	33	702	18	8.5	44
103*	130	60	33	703	30	13.5	44
108	130	59	37	704	30	13.5	44
109*	125	53	33	705	20	9	44
121*	40	18	33	706	30	9	44
122*	50	23	33	707	32	14.5	44
123*	80	36	33	708	32	14.5	44
124*	90	42	33	730	20	9	45
201*	45	20.5	35	731	20	9	45
202*	26	12	35	732	32	14.5	45
203*	26	12	35	733	32	14.5	45
204*	26	12	35	734	22	10	45
205*	45	20.5	35	735	22	10	45
206*	45	20.5	35	736	34	15.5	45
207*	45	20.5	35	737	34	15.5	45
208	89	22	37	740*	28	12.5	42
209*	62	29	35	741*	48	22	40
221*	22	10	35	742*	60	27	40
301	12	5.5	38	743*	68	31	40
303	12	5.5	38	750	24	11	46
304	12	5.5	38	751	24	11	46
401	15	7	39	752	36	16	46
402	12	5.5	39	753	36	16	46
403	28	12.5	39	754	26	12	46
404	15	7	39	755	26	12	46
405	12	19	39	756	38	17	46
406	70	32	39	757	38	17	46
				802	185	82	40
				804	50	22.5	42

* Add weights from the table below to the base model weight for VV, VVT, or VH configurations with flanges.

VV, VVT and VH Additional Weights

Size	150#		300#		600#	
	pounds	kilograms	pounds	kilograms	pounds	kilograms
1"	5	2.5	8	4	9	4.5
1-1/2"	8	4	15	7	15	7
2"	12	5.5	16	7.5	18	8.5

Weights shown in this table include two flanges, pipe nipples, and fittings.

Note: Consult the factory for additional weight due to accessories or non-standard requirements.

The specific gravity of water changes depending on its temperature and pressure. The chart below lists properties of saturated steam. Saturated steam is the state where water is in transition between liquid and vapor. The chart provides the process temperature with the associated pressure and specific gravity of the condensate water. If a water application has a high temperature and low pressure, condensate will only be present at the temperature that corresponds to the maximum pressure. Select the proper row based on the temperature and pressure, and read the specific gravity.

Figures are based on saturated steam.

Boiling Temperature F°	Vacuum Inches Hg	Specific Gravity	Boiling Temperature F°	Pressure psi	Specific Gravity	Boiling Temperature F°	Pressure psi	Specific Gravity
32	29.74	.9999	212	0.0	.96	450	407.0	.82
40	29.67	1.0000	220	2.49	.96	460	451.2	.81
50	29.56	.9997	230	6.08	.95	470	498.8	.80
60	29.40	.9990	240	10.27	.95	480	550.1	.80
70	29.18	.9980	250	15.13	.94	490	605.2	.79
80	28.89	.9966	260	20.14	.94	500	664.3	.78
90	28.50	.9950	270	27.17	.93	510	728.3	.77
100	27.99	.9931	280	34.52	.93	520	795.3	.76
110	27.33	.9909	290	42.87	.92	530	868.3	.76
120	26.48	.9886	300	52.30	.92	540	945.3	.74
130	25.40	.9860	310	63.00	.91	550	1028.3	.73
140	24.04	.9832	320	75.00	.91	560	1116.3	.71
150	22.35	.9803	330	89.3	.91	570	1209.3	.70
160	20.27	.9772	340	103.3	.90	580	1308.3	.69
170	17.72	.9730	350	119.9	.89	590	1414.3	.68
180	14.63	.9704	360	138.3	.88	600	1529.3	.67
190	10.91	.9668	370	158.5	.88	610	1644.3	.66
200	6.46	.9631	380	180.9	.87	620	1769.3	.65
210	1.17	.9592	390	205.4	.86	630	1902.3	.63
			400	232.3	.86	640	2042.3	.62
			410	261.6	.85	650	2190.3	.60
			420	293.4	.84	660	2346.3	.58
			430	328.4	.84	670	2511.3	.56
			440	366.2	.83	680	2690	.49
						690	2883	.48
						700	3075	.44
						705	3189	.32

Level Detectors

100 SERIES CALIBRATION DIMENSIONS

The chart here provides typical standard Set Points. As the specific gravity used on a level detector changes, the Set Points will also change. These values are based on the specific gravity listed and units with "B" trim and an A1 detector. For other materials or detectors, please consult factory. If a specific Set Point is needed, please use the "SC" option found in the accessories section of this catalog.

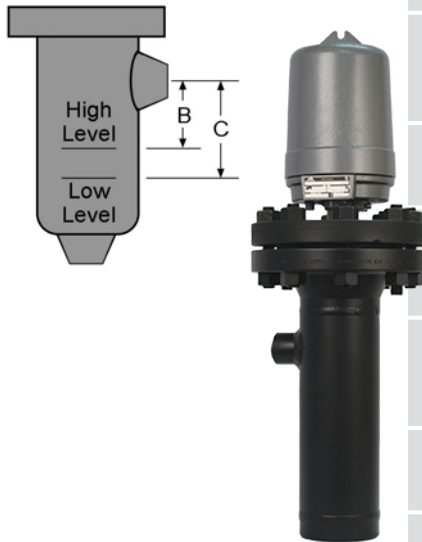

Model	Specific Gravity	B inch (mm)	C inch (mm)
101	.52	3-1/4 (83)	4-7/16 (113)
	1.0	5-1/4 (133)	5-15/16 (151)
102	.62	2-3/4 (70)	3-13/16 (97)
	1.0	4-7/16 (113)	5-1/8 (130)
103	.51	3-1/4 (83)	3-7/8 (98)
	1.0	4-13/16 (122)	5-3/16 (132)
104	.62	3-3/8 (86)	3-15/16 (100)
	1.0	4-5/8 (117)	5 (127)
109	.38	4-3/4 (121)	5-15/16 (151)
	1.0	7-1/4 (184)	7-9/16 (192)
121	.66	2-11/16 (68)	4-1/8 (105)
	1.0	3-13/16 (97)	4-13/16 (122)
122	.66	2-1/2 (64)	3-15/16 (100)
	1.0	3-5/8 (92)	4-5/8 (117)
123	.93	2-7/8 (73)	3-13/16 (97)
	1.0	3-3/16 (81)	4-1/16 (103)
124	.94	2-7/8 (73)	3-13/16 (97)
	1.0	3-1/8 (79)	4 (102)

Chamber Dimensions listed are for reference only and are expressed as millimeters over inches. (Linear = mm/in.) They are subject to change without notice. Contact SOR for certified drawings of particular models or if special dimensions are required. "W" designates electrical connection, see page 22 for more housing information.

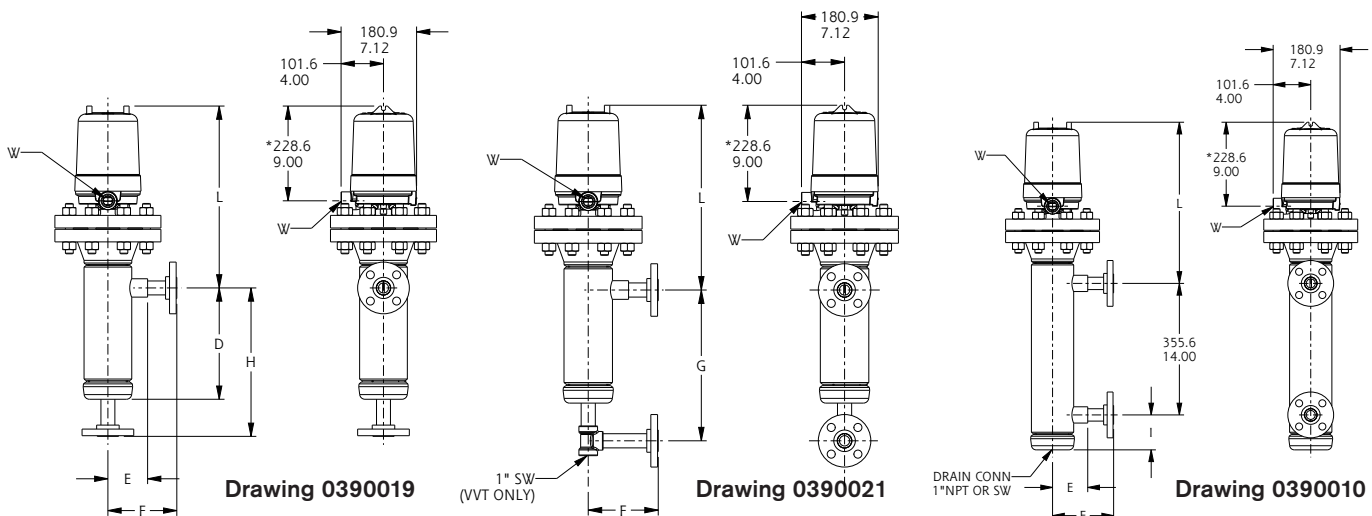

1" Connection

Model	D ^{1,2}	E ^{1,2}	F ⁴	G	H ⁴	I ²	L ²
	inch (mm)	inch (mm)	inch (mm)	inch (mm)	inch (mm)	inch (mm)	inch (mm)
101	10-1/2 (267)	3-3/4 (95)	6-1/2 (165)	14 (356)	14 (356)	3-3/4 (95)	16-5/8 (422)
102							17-5/16 (440)
103	10-1/4 (260)	4-13/16 (122)	7-7/16 (189)	14 (356)	14 (356)	4-9/16 (116)	18 (457)
104							19-3/4 (502)
109	12-5/8 (321)	5-13/16 (148)	8-7/16 (214)	16 (406)	16 (406)	7-1/2 (191)	17-13/16 (452)
121	9 (229)	3-1/4 (83)	6 (152)	14 (356)	14 (356)	3-3/4 (95)	16-3/8 (416)
122							16-15/16 (430)
123	10-1/2 (267)	3-3/4 (95)	6-1/2 (165)	14 (356)	14 (356)	3-3/4 (95)	17-5/16 (440)
124							18-3/4 (476)

1-1/2" Connection

Model	D ^{1,2}	E ^{1,2}	F ⁴	G	H ⁴	I ²	L ²
	inch (mm)	inch (mm)	inch (mm)	inch (mm)	inch (mm)	inch (mm)	inch (mm)
101	10-1/2 (267)	4 (102)	6-1/2 (165)	14 (356)	14 (356)	3-3/4 (95)	16-5/8 (422)
102							17-5/16 (440)
103	10-1/4 (260)	5-1/16 (129)	7-7/16 (189)	14 (356)	14 (356)	4-9/16 (116)	18 (457)
104							19-3/4 (502)
109	13-1/16 (332)	6-1/16 (154)	8-7/16 (214)	16 (406)	16 (406)	7-1/2 (191)	17-13/16 (452)
121	9 (229)	3-1/2 (89)	6 (152)	14 (356)	14 (356)	3-3/4 (95)	16-3/8 (416)
122							16-15/16 (430)
123	10-1/2 (267)	4 (102)	6-1/2 (165)	14 (356)	14 (356)	3-3/4 (95)	17-5/16 (440)
124							18-3/4 (476)

2" Connection

Model	D ^{1,2}	E ^{1,2}	F ⁴	G	H ⁴	I ^{2,3}	L ^{2,3}
	inch (mm)	inch (mm)	inch (mm)	inch (mm)	inch (mm)	inch (mm)	inch (mm)
101	10-1/2 (267)	4-5/16 (110)	6-1/2 (165)	14 (356)	14 (356)	4-3/4 (121)	17-5/8 (448)
102							18-5/16 (467)
103	10-1/4 (260)	5-3/8 (137)	7-7/16 (189)	14 (356)	14 (356)	4-9/16 (116)	19 (483)
104							20-3/4 (527)
109	13-3/8 (340)	6-3/8 (162)	8-7/16 (214)	16 (406)	16 (406)	8-1/2 (216)	18-13/16 (478)
121	-	-	6 (152)	14 (356)	14 (356)	3-3/4 (95) ⁵	16-3/8 (416) ⁵
122							16-15/16 (430) ⁵
123	10-1/2 (267)	4-5/16 (110)	6-1/2 (165)	14 (356)	14 (356)	4-3/4 (121)	18-5/16 (465)
124							19-3/4 (502)

Notes

- Dimensions D and E apply to socket-weld connections only. Consult factory for NPT dimensions.
- Consult factory for dimensions for materials other than carbon steel.
- Applies to socket weld or NPT process connections only.
- Consult the factory if weld neck process flanges are required. Dimensions may vary from those shown above.
- Applies to flanged process connections only.

Level Detectors

200 SERIES CALIBRATION DIMENSIONS

The chart here provides typical standard Set Points. As the specific gravity used on a level detector changes, the Set Points will also change. These values are based on the specific gravity listed and units with "B" trim and an A1 detector. For other materials or detectors, please consult factory. If a specific Set Point is needed, please use the "SC" option found in the accessories section of this catalog.

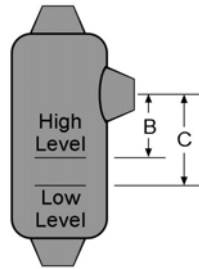

Model	Specific Gravity	B inch (mm)	C inch (mm)
201	.38	3-3/16 (81)	4 (102)
	1.0	5-3/16 (132)	5-9/16 (141)
202	.52	3-1/4 (83)	4-7/16 (113)
	1.0	5-1/4 (133)	5-15/16 (151)
203	.61	3 (76)	4-1/16 (103)
	1.0	4-3/4 (121)	5-7/16 (138)
204	.91	3 (76)	3-15/16 (100)
	1.0	3-3/8 (86)	4-1/4 (108)
205	.50	3 (76)	3-11/16 (94)
	1.0	4-11/16 (119)	5 (127)
206	.65	3-1/2 (89)	4-1/4 (108)
	1.0	4-5/8 (117)	5-1/16 (129)
207	.61	3 (76)	3-9/16 (90)
	1.0	4-5/16 (110)	4-5/8 (117)
209	.38	4-3/4 (121)	5-1/4 (133)
	1.0	7-1/4 (184)	7-1/2 (191)
221	.64	2-9/16 (65)	4-1/16 (103)
	1.0	3-13/16 (97)	4-13/16 (122)

Dimensions listed are for reference only and are expressed as millimeters over inches. (Linear = mm/in.) They are subject to change without notice. Contact SOR for certified drawings of particular models or if special dimensions are required. "W" designates electrical connection, see page 22 for more housing information.

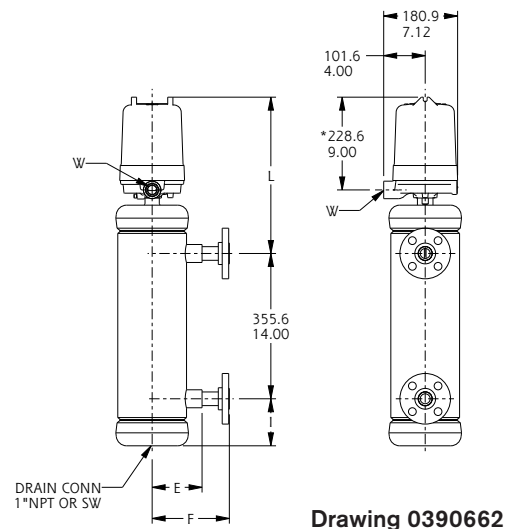
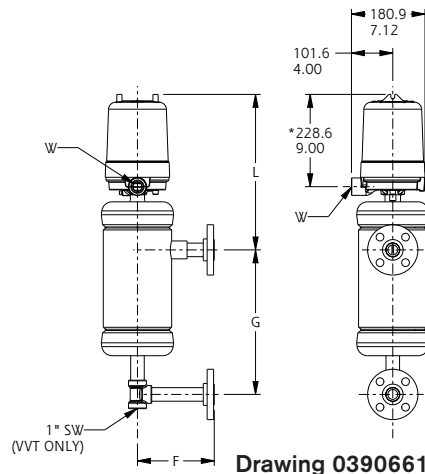
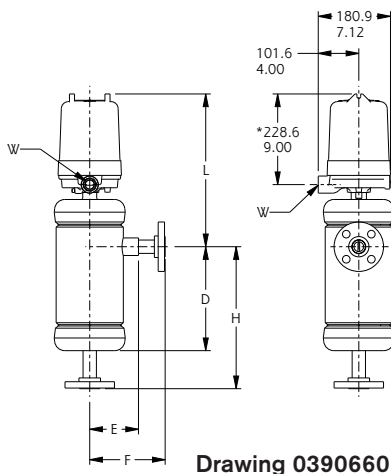

1" Connections

Model	D ^{1,2}	E ^{1,2}	F ⁴	G	H ⁴	I ^{1,2}	L ²
	inch (mm)	inch (mm)	inch (mm)	inch (mm)	inch (mm)	inch (mm)	inch (mm)
201	10-1/4 (260)	4-13/16 (122)	7-7/16 (189)	14 (356)	14 (356)	4-9/16 (116)	15-3/16 (386)
202	10-1/2 (267)	3-3/4 (95)	6-1/2 (165)	14 (356)	14 (356)	3-3/4 (95)	14-3/8 (365)
203							
204							
205	10-1/4 (260)	4-13/16 (122)	7-7/16 (189)	14 (356)	14 (356)	4-9/16 (116)	15-3/16 (386)
206							
207							
209	12-5/8 (321)	5-13/16 (148)	8-7/16 (214)	16 (406)	16 (406)	7-1/2 (191)	18-1/16 (459)
221	9 (229)	3-1/4 (83)	6 (152)	14 (356)	14 (356)	3-3/4 (95)	14-3/8 (365)

1-1/2" Connections

Model	D ²	E ²	F ⁴	G	H ⁴	I ²	L ²
	inch (mm)	inch (mm)	inch (mm)	inch (mm)	inch (mm)	inch (mm)	inch (mm)
201	10-1/4 (260)	4-13/16 (122)	7-7/16 (189)	14 (356)	14 (356)	4-9/16 (116)	15-3/16 (386)
202	10-1/2 (267)	4 (102)	6-1/2 (165)	14 (356)	14 (356)	3-3/4 (95)	14-3/8 (365)
203							
204							
205	10-1/4 (260)	5-1/16 (129)	7-7/16 (189)	14 (356)	14 (356)	4-9/16 (116)	15-3/16 (386)
206							
207							
209	13-1/16 (332)	6-1/16 (154)	8-7/16 (214)	16 (406)	16 (406)	7-1/2 (191)	18-1/16 (459)
221	9 (229)	3-1/2 (89)	6 (152)	14 (356)	14 (356)	3-3/4 (95)	14-3/8 (365)

2" Connections

Model	D ²	E ²	F ⁴	G	H ⁴	I ^{2,3}	L ^{2,3}
	inch (mm)	inch	inch	inch	inch	inch	inch
201	10-1/4 (260)	5-3/8 (137)	7-7/16 (189)	14 (356)	14 (356)	5-9/16 (141)	16-3/16 (411)
202	10-1/2 (267)	4-5/16 (110)	6-1/2 (165)	14 (356)	14 (356)	4-3/4 (121)	15-3/8 (391)
203							
204							
205	10-1/4 (260)	5-3/8 (137)	7-7/16 (189)	14 (356)	14 (356)	5-9/16 (141)	16-3/16 (411)
206							
207							
209	13-3/8 (340)	6-3/16 (162)	8-7/16 (214)	16 (406)	16 (406)	7-1/2 (191)	19-1/16 (484)
221	-	-	6 (152)	14 (356)	14 (356)	3-3/4 (95) ⁵	14-3/8 (365)

Notes

1. Dimensions D and E apply to socket-weld connections only. Consult factory for NPT dimensions.
2. Consult factory for dimensions for materials other than carbon steel.
3. Applies to socket weld or NPT process connections only.
4. Consult the factory if weld neck process flanges are required. Dimensions may vary from those shown above.
5. Applies to flanged process connections only.

Level Detectors

108/208 CHAMBER DIMENSIONS

Dimensions listed are for reference only and are expressed as millimeters over inches. (Linear = mm/in.) They are subject to change without notice. Contact SOR for certified drawings of particular models or if special dimensions are required. "W" designates electrical connection, see page 22 for more housing information.

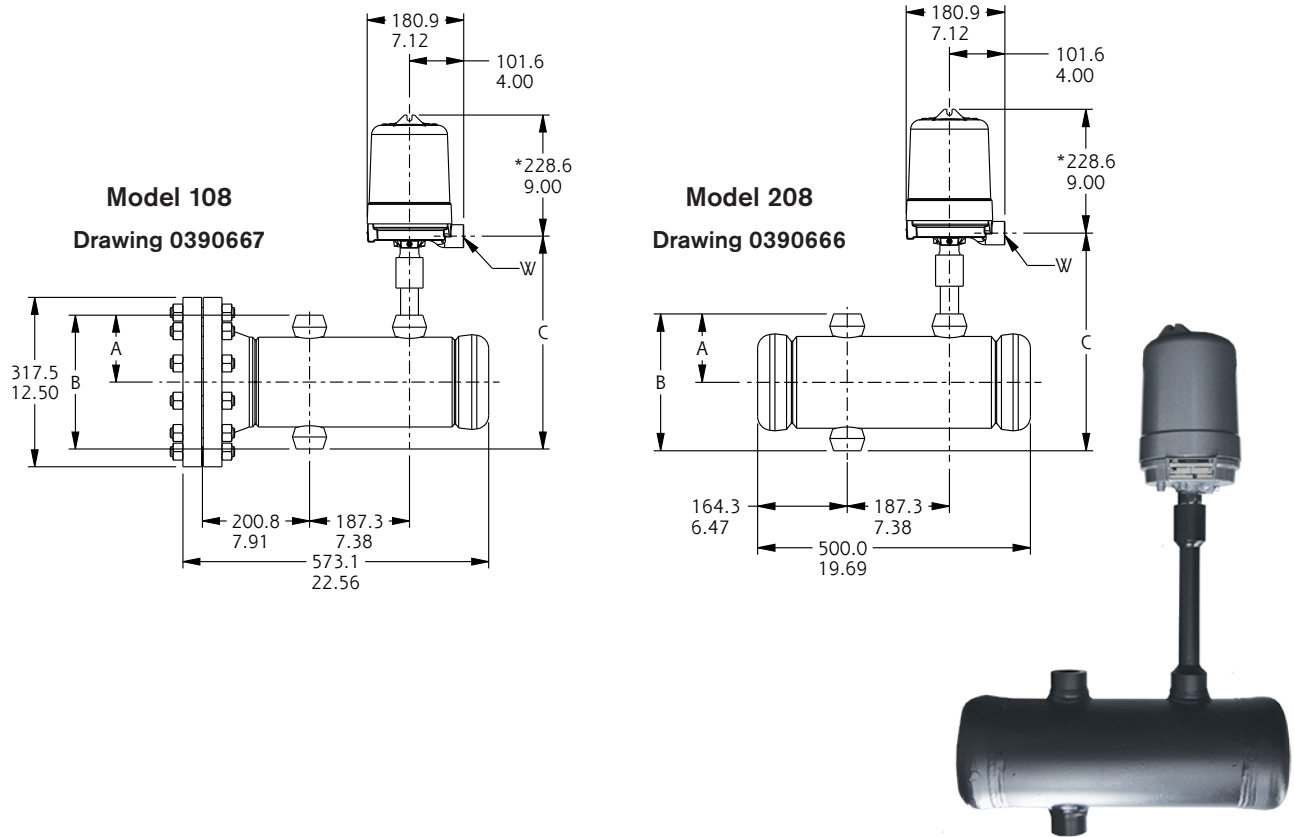

Model	Connection Size	A	B	C
		inch (mm)	inch (mm)	inch (mm)
108	1"	4-13/16 (122)*	9-5/8 (244)*	15-1/2 (394)
	1-1/2"	5-1/16 (129)*	10-1/8 (258)*	15-3/4 (401)*
	2"	5-3/8 (137)*	10-3/4 (274)*	16-1/8 (409)*
208	1"	4-15/16 (125)	9-7/8 (250)	15-5/8 (396)
	1-1/2"	5-1/16 (129)*	10-1/8 (258)*	15-3/4 (401)*
	2"	5-3/8 (137)*	10-3/4 (274)*	16-1/8 (409)*

*Dimensions valid for socket weld process connections. Consult factory for threaded connection dimensions.

Level Detectors

300 SERIES UNIT DIMENSIONS

Dimensions in this catalog are for reference only. They may be changed without notice. Contact the factory for certified drawings for a particular model number. Dimensions are expressed as millimeters over inches. (Linear = mm/in.) "W" designates electrical connection, see page 22 for more housing information.

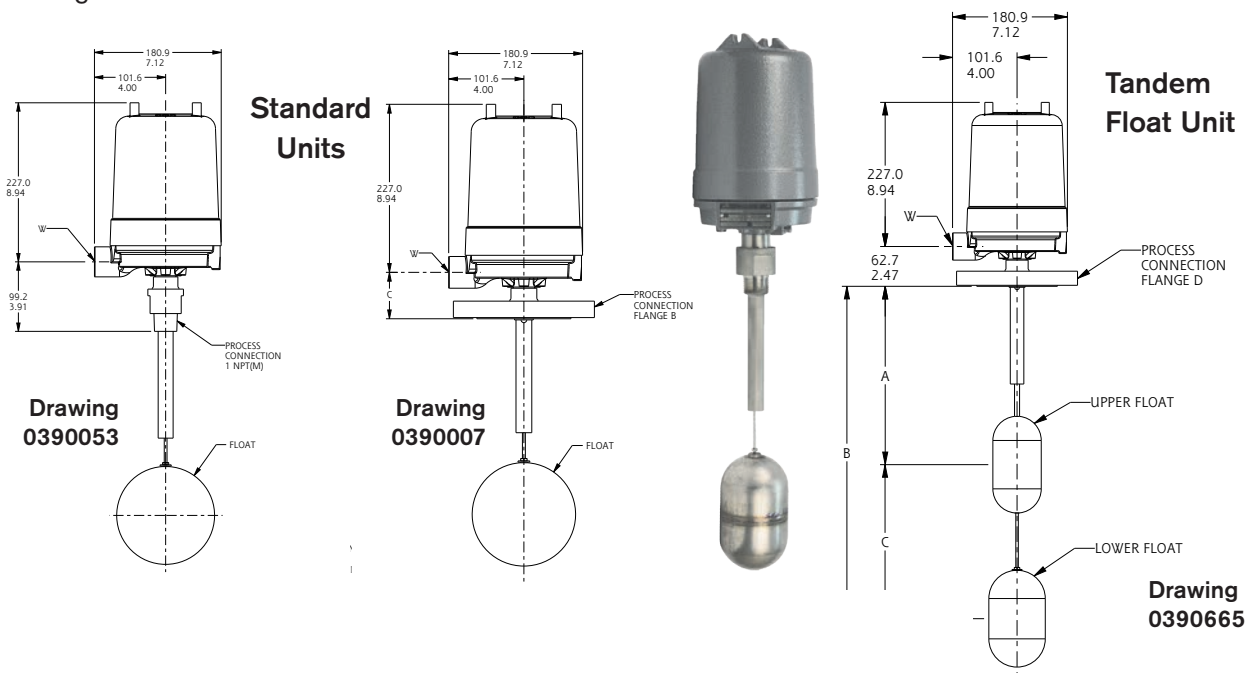

Standard Units			
Series	Float Size	Minimum Insertion	Maximum Insertion
		inch (mm)	inch (mm)
303	3-1/2 x 6"	4-1/2 (114)	48 (1219)
301	5-1/2"	4-1/4 (108)	
304			

** See Housing section (page 22).

*** M20 adapters are brass. Contact the factory for alternate materials.

Tandem Float Units in inches (mm)							
Series	Float Size	High Insertion		Low Insertion		Differential	
		Minimum	Maximum	Minimum	Maximum	Minimum	Maximum
303	3-1/2 x 6"	4-1/2 (114)	40 (1016)	12 (305)	48 (1219)	8 (203)	43-1/2 (1105)
301	5-1/2"	4-1/4 (108)	41 (1041)	11 (279)	48 (1219)	7 (178)	43-3/4 (1111)
304							

Notes

- Standard Units:** It is important to consider the installation configuration when selecting the process connection. Be sure that the float will fit through the process connection, or that the vessel has access to attach the float from inside the vessel after instrument installation. Minimum 5-3/4" (146 mm) overhead clearance required to remove housing cover.
- Tandem Float Units:** It is important to consider the installation configuration when selecting the process connection. Be sure that the float will fit through the process connection. Tandem floats are not removable and must be installed through the nozzle opening. Operating specific gravity and insertion depths must be specified. Minimum 5-3/4" (146 mm) overhead clearance required to remove housing cover.

Level Detectors

400 SERIES CHAMBER DIMENSIONS

Dimensions in this catalog are for reference only. They may be changed without notice. Contact the factory for certified drawings for a particular model number. Dimensions are expressed as millimeters over inches. (Linear = mm/in.) "W" designates electrical connection, see page 22 for more housing information.

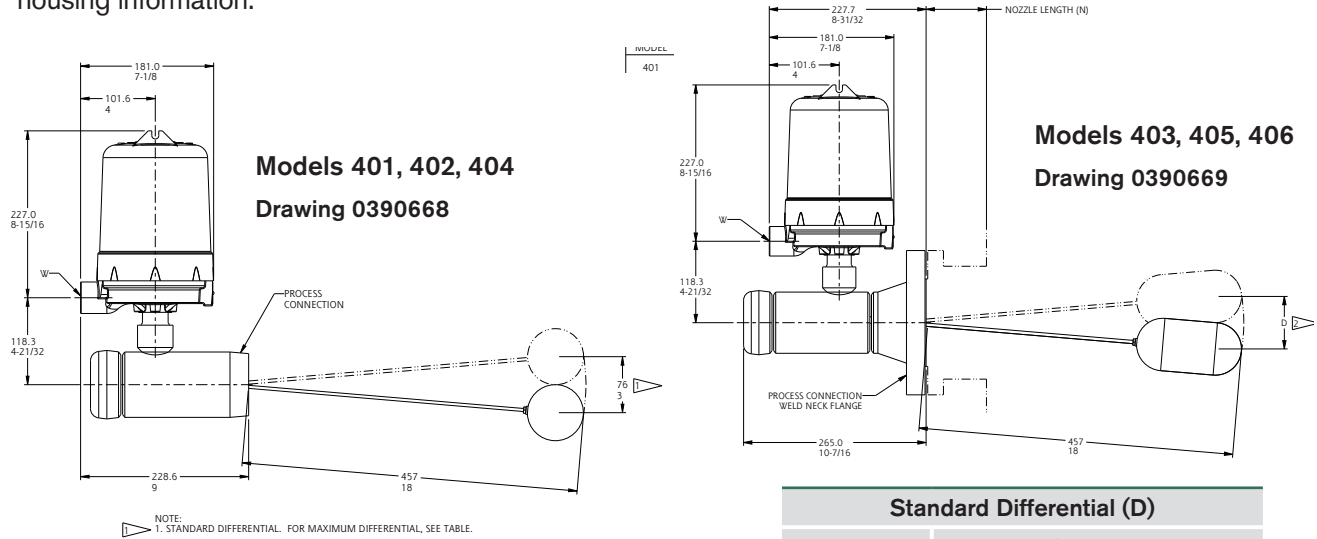

Standard Differential (D)	
Model	D @ Minimum Specific Gravity
	inch (mm)
401	3 (76)
402	
403	
404	
405	2-3/4 (70)
406	

Note: With anti-vibration, extra-high temperature and pneumatic detector, minimum differential will increase.

Maximum Differential (D) Differential Dimension "D" is calibrated to the minimum shown above as standard. Wider differentials are available by placing an SC in the accessory section of the model number. The charts below give the maximum differentials available.

Model	NPT Units - Customer Mounting	
	1/2 Coupling	Full Coupling
	inch (mm)	inch (mm)
401	12-3/8 (356)	10-1/4 (292)
402	8-7/8 (292)	8-7/8 (292)
404	12-3/8 (356)	10-1/4 (292)

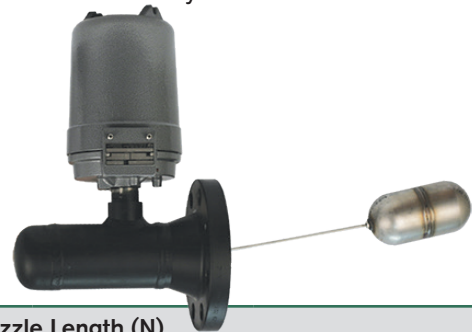

Model	Flanged Units - Customer Nozzle Length (N)				
	2 (51)	4 (102)	6 (152)	8 (203)	10 (254)
403	13 (330)	9 (229)	7 (178)	5 (127)	4-1/2 (114)
405*	6 (152)		5 (127)		
406*	6 (152)		5 (127)		

*Based on 4-inch flange size.

Level Detectors

741-743 & 802 CHAMBER DIMENSIONS

The chart here provides typical standard Set Points. As the specific gravity used on a level detector changes, the Set Points will also change. These values are based on the specific gravity listed and units with "B" trim and an A1 detector. For other materials or detectors, please consult factory. If a specific Set Point is needed, please use the "SC" option found in the accessories section of this catalog.

Model	Specific Gravity	B inch (mm)	C inch (mm)
741	.43	1-13/16 (46)	4-5/8 (117)
	1.0	4-9/16 (116)	6-1/16 (154)
742	.43	1-13/16 (46)	4-5/8 (117)
	1.0	4-9/16 (116)	6-1/16 (154)
743	.43	1-13/16 (46)	4-5/8 (117)
	1.0	4-9/16 (116)	6-1/16 (154)
802	.41	2-3/8 (60)	5-5/16 (135)
	1.0	5-1/16 (129)	6-7/16 (164)

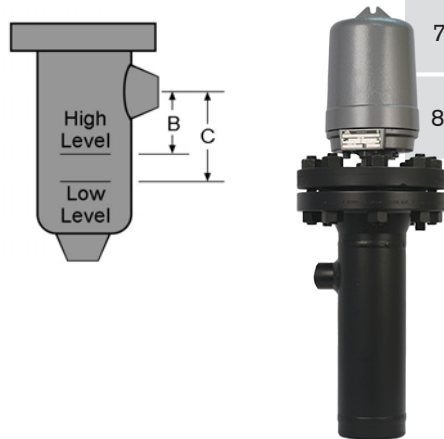

Dimensions in this catalog are for reference only. They may be changed without notice. Contact the factory for certified drawings for a particular model number. Dimensions are expressed as millimeters over inches. (Linear = mm/in.) "W" designates electrical connection, see page 22 for more housing information.

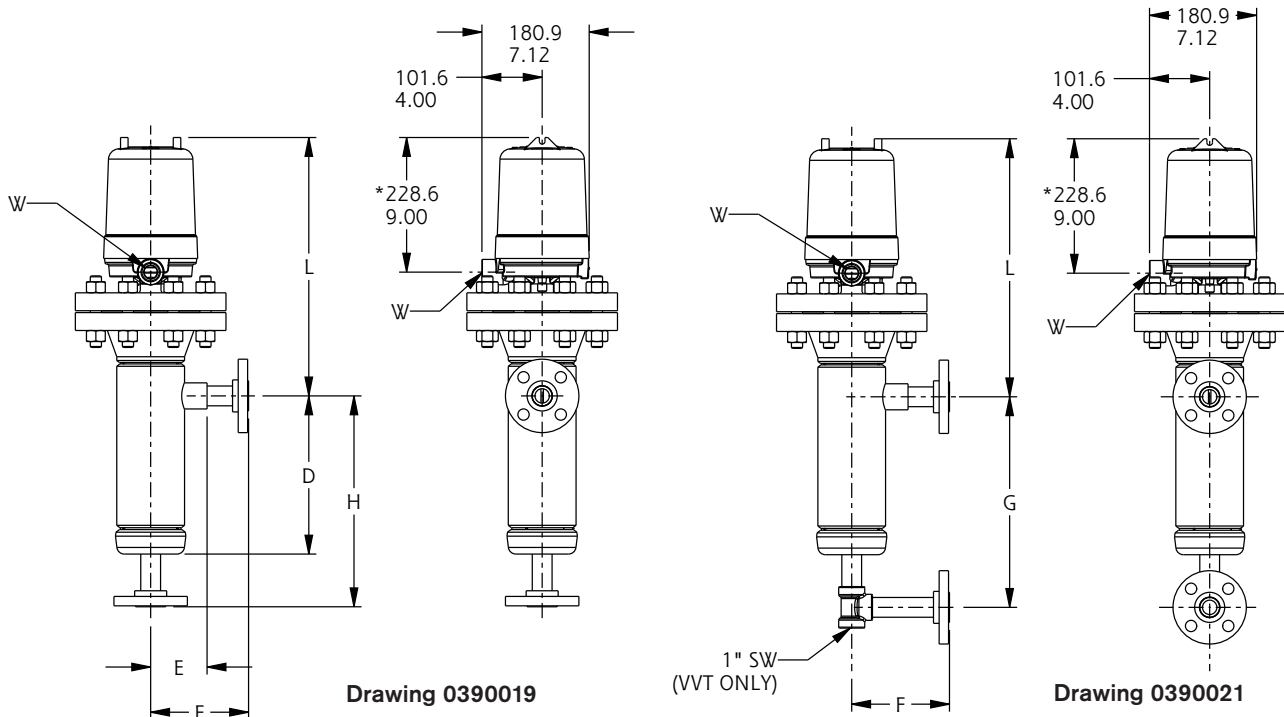

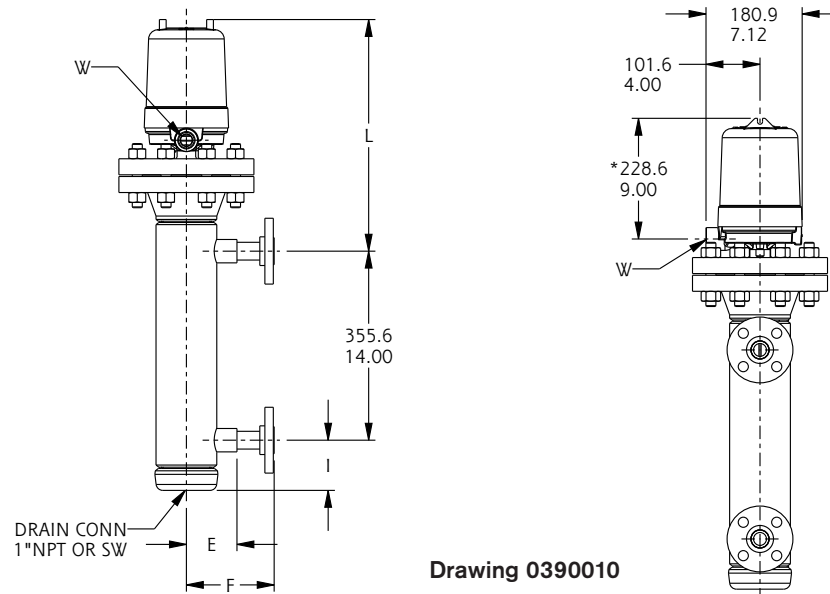

Drawing 0390010

1" Connections

Model	D ^{1,2}	E ^{1,2}	F ⁴	G	H ⁴	I ²	L ²
	inch (mm)	inch (mm)	inch (mm)	inch (mm)	inch (mm)	inch (mm)	inch (mm)
741	13 (330)	3-1/4 (83)	6 (152)	16 (406)	16 (406)	3-3/4 (95)	19-5/16 (491)
742							19-1/2 (495)
743							19-7/8 (505)
802	12-3/4 (324)	3-7/8 (98)	8 (203)	16 (406)	16 (406)	7-3/4 (197)	20-3/4 (527)

1-1/2" Connections

Model	D ²	E ²	F ⁴	G	H ⁴	I ²	L ²
	inch (mm)	inch (mm)	inch (mm)	inch (mm)	inch (mm)	inch (mm)	inch (mm)
741	13 (330)	3-1/2 (89)	6 (152)	16 (406)	16 (406)	3-3/4 (95)	19-5/16 (491)
742							19-1/2 (495)
743							19-7/8 (505)
802	12-7/8 (327)	4 (102)	8 (203)	16 (406)	16 (406)	7-3/4 (197)	20-3/4 (527)

2" Connections

Model	D ²	E ²	F ⁴	G	H ⁴	I ^{2,3}	L ^{2,3}
	inch (mm)	inch (mm)	inch (mm)	inch (mm)	inch (mm)	inch (mm)	inch (mm)
741	-	-	6 (152)	16 (406)	16 (406)	3-3/4 (95) ⁵	19-5/16 (491) ⁵
742							19-1/2 (495) ⁵
743							19-7/8 (505) ⁵
802	13-3/16 (335)	4-5/16 (110)	8 (203)	16 (406)	16 (406)	8-3/4 (222)	21-5/16 (541)

Notes

1. Dimensions D and E apply to socket-weld connections only. Consult factory for NPT dimensions.
2. Consult factory for dimensions for materials other than carbon steel.
3. Applies to socket weld or NPT process connections only.
4. Consult the factory if weld neck process flanges are required. Dimensions may vary from those shown above.
5. Applies to flanged process connections only.

Level Detectors

740 & 804 CALIBRATION DIMENSIONS

The chart here provides typical standard Set Points. As the specific gravity used on a level detector changes, the Set Points will also change. These values are based on the specific gravity listed and units with "B" trim and an A1 detector. For other materials or detectors, please consult factory. If a specific Set Point is needed, please use the "SC" option found in the accessories section of this catalog.

Model	Specific Gravity	B inch (mm)	C inch (mm)
740	.43	1-13/16 (46)	4-5/8 (143)
	1.0	4-9/16 (116)	6-1/16 (154)
804	.41	2-3/8 (60)	5-5/16 (135)
	1.0	5-1/16 (129)	6-7/16 (164)

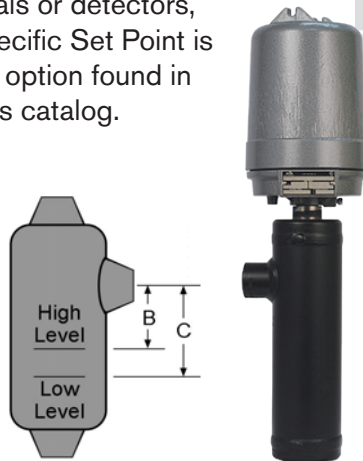

Dimensions in this catalog are for reference only. They may be changed without notice. Contact the factory for certified drawings for a particular model number. Dimensions are expressed as millimeters over inches. (Linear = mm/in.) "W" designates electrical connection, see page 22 for more housing information.

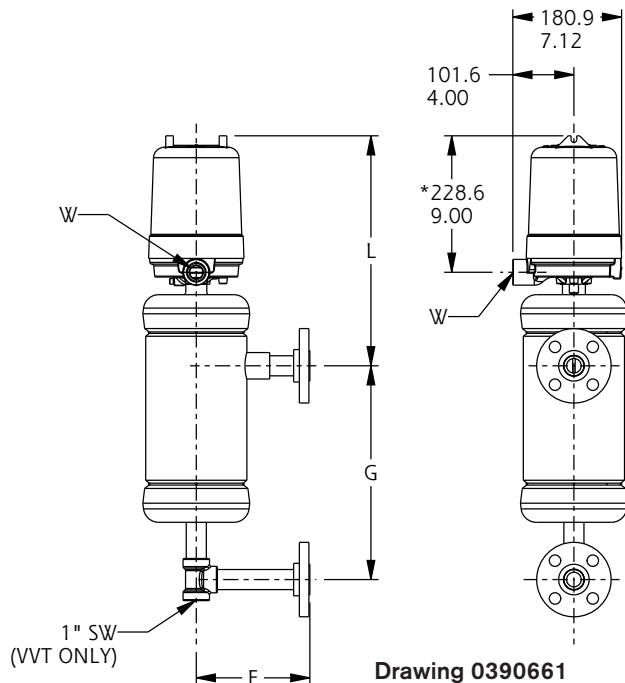
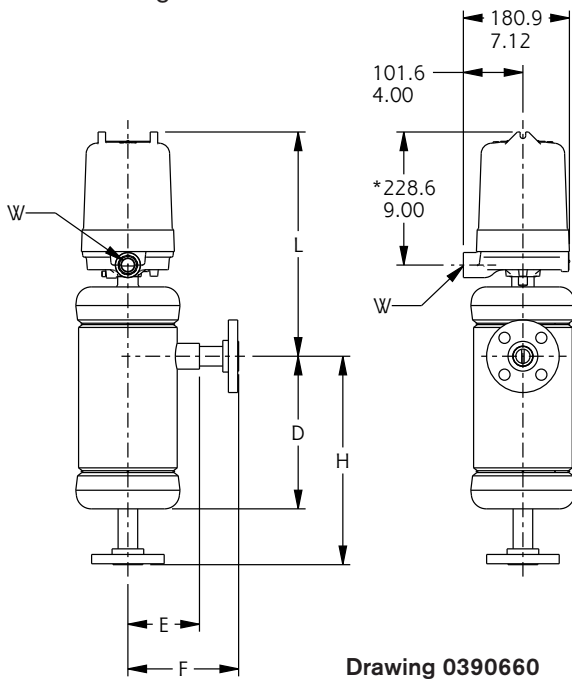

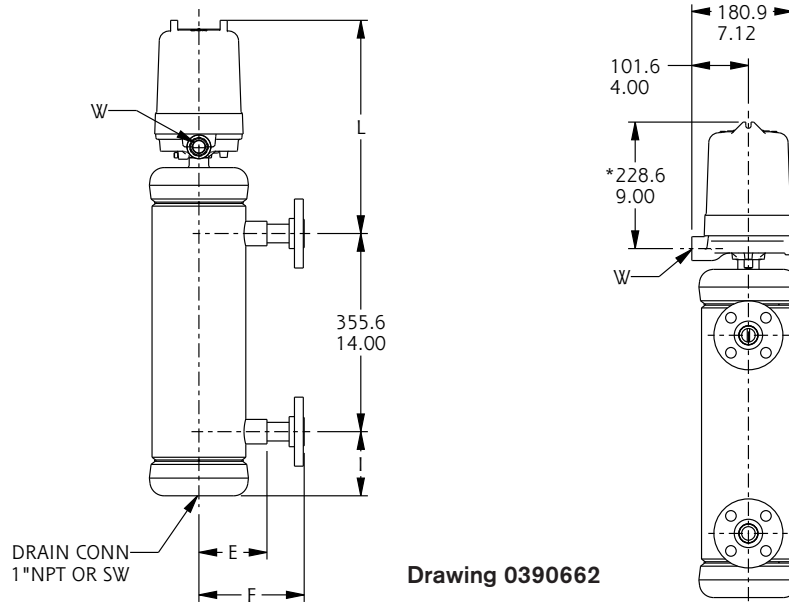

1" Connection

Model	D ^{1,2}	E ^{1,2}	F ⁴	G	H ⁴	I ²	L ²
	inch (mm)	inch (mm)	inch (mm)	inch (mm)	inch (mm)	inch (mm)	inch (mm)
740	13 (330)	3-1/4 (83)	6 (152)	16 (406)	16 (406)	3-3/4 (95)	20-1/4 (514)
804	12-3/4 (324)	3-7/8 (98)	8 (203)	16 (406)	16 (406)	7-3/4 (197)	21-3/4 (552)

1-1/2" Connection

Model	D ²	E ²	F ⁴	G	H ⁴	I ²	L ²
	inch (mm)	inch (mm)	inch (mm)	inch (mm)	inch (mm)	inch (mm)	inch (mm)
740	13 (330)	3-1/2 (89)	6 (152)	16 (406)	16 (406)	3-3/4 (95)	20-1/4 (514)
804	12-7/8 (327)	4 (102)	8 (203)	16 (406)	16 (406)	7-3/4 (197)	21-3/4 (552)

2" Connection

Model	D ²	E ²	F ⁴	G	H ⁴	I ^{2,3}	L ^{2,3}
	inch (mm)	inch (mm)	inch (mm)	inch (mm)	inch (mm)	inch (mm)	inch (mm)
740	-	-	6 (152)	16 (406)	16 (406)	3-3/4 (95) ⁵	20-1/4 (514) ⁵
804	13-3/16 (335)	4-5/16 (110)	8 (203)	16 (406)	16 (406)	8-3/4 (222)	21-3/4 (552)

Notes

1. Dimensions D and E apply to socket-weld connections only. Consult factory for NPT dimensions.
2. Consult factory for dimensions for materials other than carbon steel.
3. Applies to socket weld or NPT process connections only.
4. Consult the factory if weld neck process flanges are required. Dimensions may vary from those shown above.
5. Applies to flanged process connections only.

Level Detectors

700 SERIES UNIT DIMENSIONS

Dimensions in this catalog are for reference only. They may be changed without notice. Contact the factory for certified drawings for a particular model number. Dimensions are expressed as millimeters over inches. (Linear = mm/in.) "W" designates electrical connection, see page 22 for more housing information.

Narrow Differential Models 701-704:

Actuation differential is approximately 1-7/16"
@ Specific Gravity of 1.0 @ 100°F.

Wide Differential Models 705-708:

Actuation differential is adjustable from approximately
9-1/2" (minimum @ Specific Gravity of 1.0 @ 100°F)
to available cable length.

Model 701/703
Narrow Differential

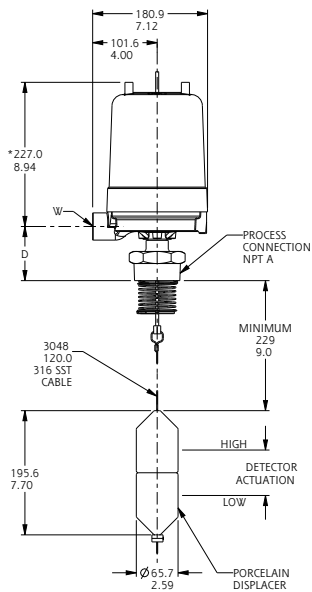

Drawing 0390670

Model 702/704
Narrow Differential

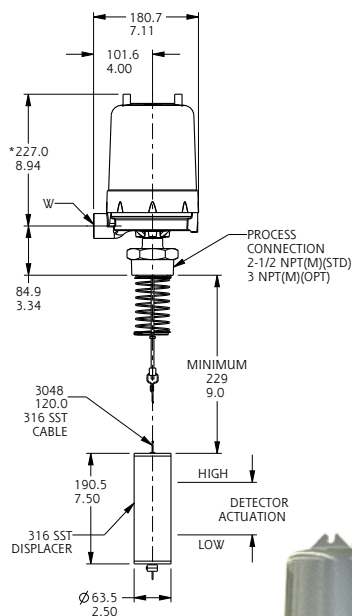

Drawing 0390671

Model 705/707
Wide Differential

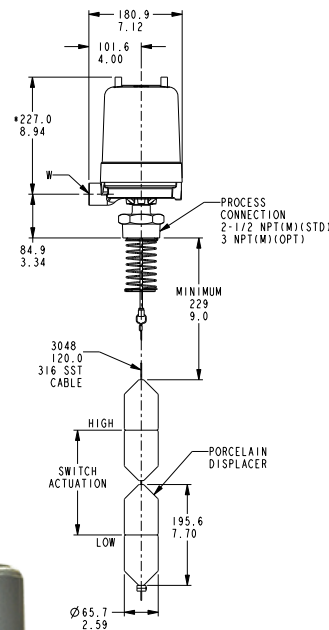

Drawing 0390672

Model 706/708
Wide Differential

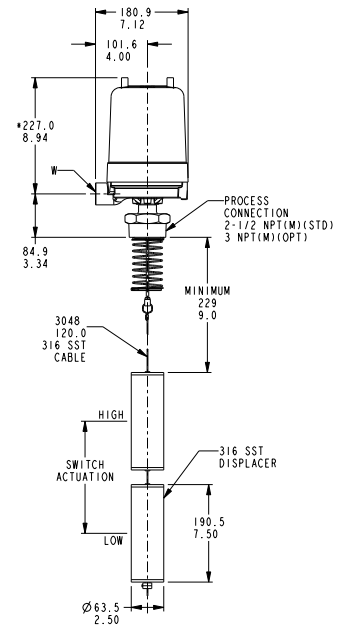

Drawing 0390673



Level Detectors

730 UNIT DIMENSIONS

Dimensions in this catalog are for reference only. They may be changed without notice. Contact the factory for certified drawings for a particular model number. Dimensions are expressed as millimeters over inches. (Linear = mm/in.) "W" designates electrical connection, see page 22 for more housing information.

Model 730/732
Narrow Differential

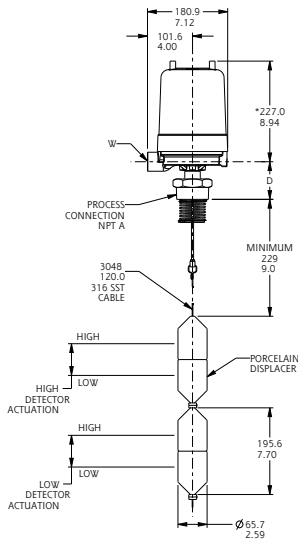

Drawing 0390677

Model 731/733
Narrow Differential

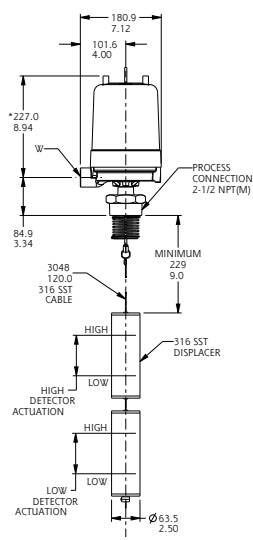

Drawing 0390678

Model 734/736
Wide Differential

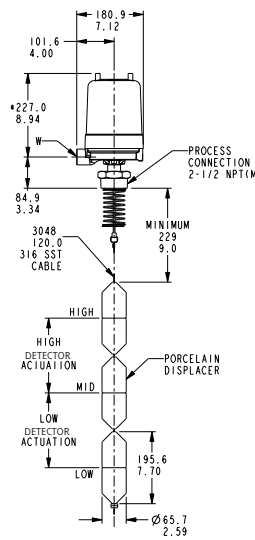

Drawing 0390679

Model 735/737
Wide Differential

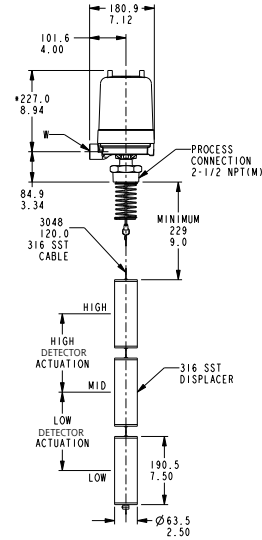

Drawing 0390680



Optional Detecting Arrangements

Dual-stage, wide differential detectors may be ordered with detecting arrangements different from those shown above. To order, select the desired arrangement below and add **SC** to the accessory section of the model number. At the time of order, specify the required arrangement number. Porcelain displacers are shown for pictorial purposes only.

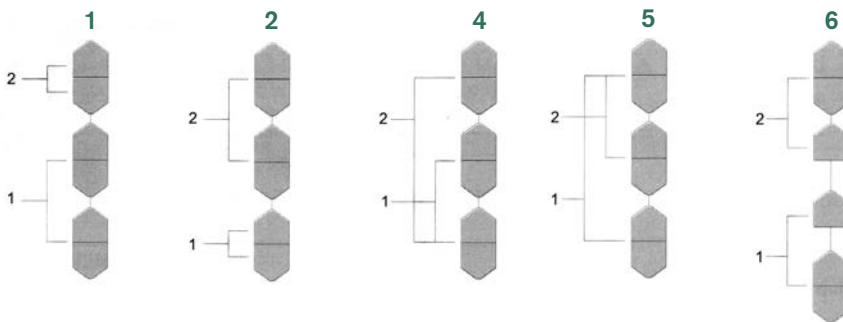

Detector Position

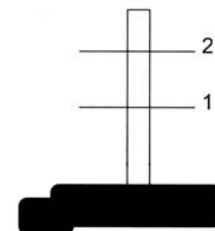

Level Detectors

750 UNIT DIMENSIONS

Dimensions in this catalog are for reference only. They may be changed without notice. Contact the factory for certified drawings for a particular model number. Dimensions are expressed as millimeters over inches. (Linear = mm/in.) "W" designates electrical connection.



Model 750/752
Narrow Differential

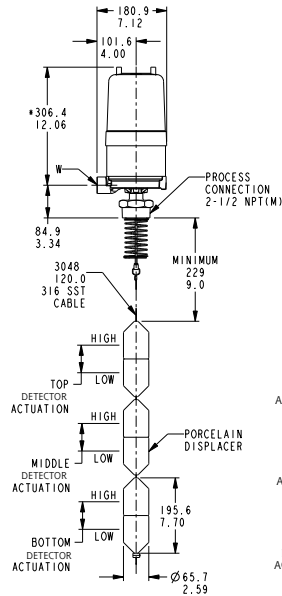

Drawing 0390681

Model 751/753
Narrow Differential

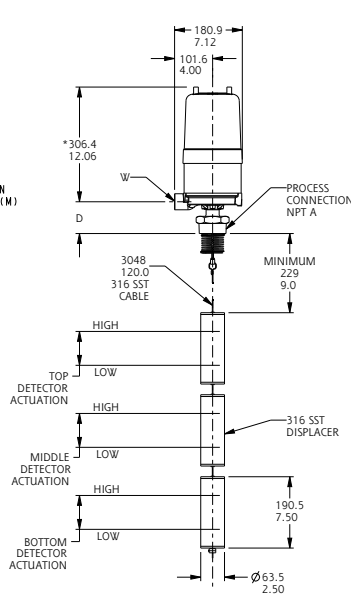

Drawing 0390682

Model 754/756
Wide Differential

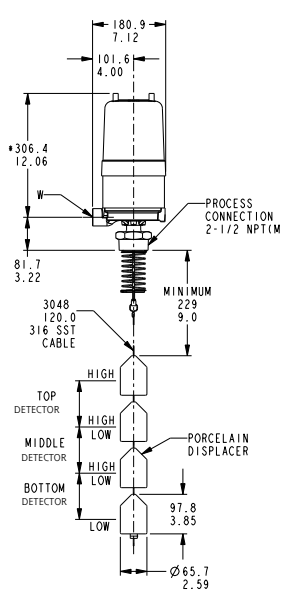

Drawing 0390683

Model 755/757
Wide Differential

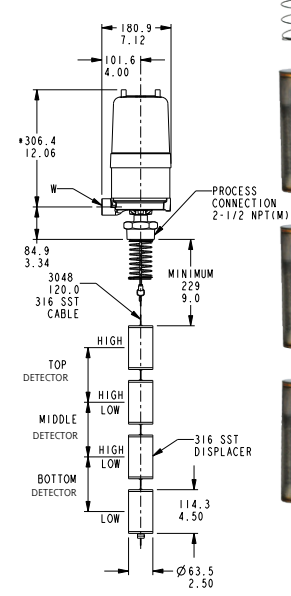

Drawing 0390684

* Minimum 8-3/4" (222 mm) overhead clearance required to remove housing cover.

Optional Detecting Arrangements

Three-stage, wide differential detectors may be ordered with detecting arrangements different from those shown above. To order, select the desired arrangement below and add **SC** to the accessory section of the model number. At the time of order, specify the required arrangement number. Porcelain displacers are shown for pictorial purposes only.

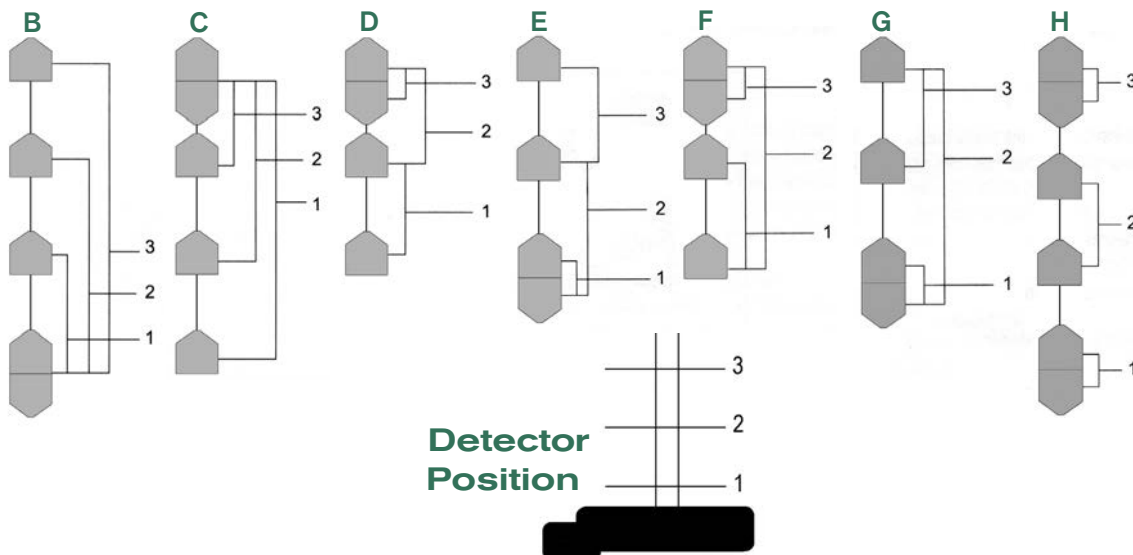



MEASUREMENT AND CONTROL

Lenexa, KS USA | 913-888-2630 | Fax 913-888-0767 | www.sorinc.net

REGIONAL OFFICES

China

SOR China | Beijing, China | china@SORInc.com
+86 10 5820 8767 | Fax +86 10 5820 8770

Middle East

SOR Measurement & Control Equipment Trading DMCC | Dubai, UAE
middleeast@SORInc.com | +971 4 278 9632 | Fax +1 913 312 3596